

**INSTALLATION, OPERATION,
AND MAINTENANCE MANUAL**
WITH PARTS LIST



0 SERIES PUMP

MODEL
04B3-F4L

THE GORMAN-RUPP COMPANY • MANSFIELD, OHIO

GORMAN-RUPP OF CANADA LIMITED • ST. THOMAS, ONTARIO, CANADA Printed in U.S.A.

©2012 The Gorman-Rupp Company

Register your new
Gorman-Rupp pump online at
www.grpumps.com

Valid serial number and e-mail address required.



The engine exhaust from this product contains chemicals known to the State of California to cause cancer, birth defects or other reproductive harm.

RECORD YOUR PUMP MODEL AND SERIAL NUMBER

Please record your pump model and serial number in the spaces provided below. Your Gorman-Rupp distributor needs this information when you require parts or service.

Pump Model: _____

Serial Number: _____

TABLE OF CONTENTS

INTRODUCTION	PAGE I – 1
SAFETY - SECTION A	PAGE A – 1
INSTALLATION – SECTION B	PAGE B – 1
Pump Dimensions	PAGE B – 1
PREINSTALLATION INSPECTION	PAGE B – 1
Battery Specifications And Installation	PAGE B – 2
POSITIONING PUMP	PAGE B – 2
Lifting	PAGE B – 2
Alignment	PAGE B – 2
Mounting	PAGE B – 2
SUCTION AND DISCHARGE PIPING	PAGE B – 3
Materials	PAGE B – 3
Line Configuration	PAGE B – 3
Connections to Pump	PAGE B – 3
Gauges	PAGE B – 3
SUCTION LINES	PAGE B – 3
Fittings	PAGE B – 3
Strainers	PAGE B – 3
Sealing	PAGE B – 3
Suction Line Positioning	PAGE B – 4
FLOAT SWITCHES	PAGE B – 4
Installation	PAGE B – 4
DISCHARGE LINES	PAGE B – 5
Siphoning	PAGE B – 5
Valves	PAGE B – 5
OPERATION – SECTION C	PAGE C – 1
PRIMING	PAGE C – 1
STARTING	PAGE C – 1
Starting	PAGE C – 2
OPERATION	PAGE C – 2
Lines With a Bypass	PAGE C – 2
Lines Without a Bypass	PAGE C – 2
Leakage	PAGE C – 2
Liquid Temperature And Overheating	PAGE C – 2
Strainer Check	PAGE C – 2
Pump Vacuum Check	PAGE C – 3
STOPPING	PAGE C – 3
Stopping	PAGE C – 3
Safety Shutdown System	PAGE C – 3
OPERATION IN EXTREME HEAT	PAGE C – 4
BEARING TEMPERATURE CHECK	PAGE C – 4
Cold Weather Preservation	PAGE C – 4
TROUBLESHOOTING – SECTION D	PAGE D – 1
PREVENTIVE MAINTENANCE	PAGE D – 3

TABLE OF CONTENTS
(continued)

PUMP MAINTENANCE AND REPAIR - SECTION E	PAGE E – 1
STANDARD PERFORMANCE CURVE	PAGE E – 1
PARTS LISTS:	
Pump Model	PAGE E – 3
Pump End Assembly	PAGE E – 5
Drive Assembly	PAGE E – 6
PUMP AND SEAL DISASSEMBLY AND REASSEMBLY	PAGE E – 7
Pump Disassembly	PAGE E – 7
Impeller Removal	PAGE E – 8
Seal Removal and Disassembly	PAGE E – 8
Separating Intermediate and Drive Assembly From Engine	PAGE E – 8
Shaft and Bearing Removal and Disassembly	PAGE E – 8
Shaft and Bearing Reassembly and Installation	PAGE E – 9
Securing Intermediate and Drive Assembly To Engine	PAGE E – 11
Seal Reassembly and Installation	PAGE E – 11
Impeller Installation	PAGE E – 13
Pump Reassembly	PAGE E – 13
Final Pump Assembly	PAGE E – 14
LUBRICATION	PAGE E – 14
Seal Assembly	PAGE E – 14
Engine	PAGE E – 14

INTRODUCTION

Thank You for purchasing a Gorman-Rupp pump. **Read this manual** carefully to learn how to safely install and operate your pump. Failure to do so could result in personal injury or damage to the pump.

This pump is an 0 Series, closed impeller, self-priming centrifugal model, designed with straight-in suction, without a suction check valve. It is designed to handle clear liquids containing specified entrained solids. The basic material of construction for wetted parts is gray iron, with bronze impeller and gray iron wear rings.

The pump is close-coupled to a four cylinder Deutz diesel engine. Refer to the manual accompanying the engine before installing or operating the pump.

Because pump installations are seldom identical, this manual cannot possibly provide detailed instructions and precautions for every aspect of each specific application. Therefore, it is the responsibility of the owner/installer of the pump to ensure that applications not addressed in this manual are performed **only** after establishing that neither operator safety nor pump integrity are compromised by the installation. Pumps and related equipment **must** be installed and operated according to all national, local and industry standards.

If there are any questions regarding the pump or its application which are not covered in this manual or in other literature accompanying this unit, please contact your Gorman-Rupp distributor, or The Gorman-Rupp Company:

The Gorman-Rupp Company
P.O. Box 1217
Mansfield, Ohio 44901-1217
Phone: (419) 755-1011

or:

Gorman-Rupp of Canada Limited
70 Burwell Road
St. Thomas, Ontario N5P 3R7
Phone: (519) 631-2870

For information or technical assistance on the engine, contact the engine manufacturer's local dealer or representative.

The following are used to alert maintenance personnel to procedures which require special attention, to those which could damage equipment, and to those which could be dangerous to personnel:



Immediate hazards which WILL result in severe personal injury or death. These instructions describe the procedure required and the injury which will result from failure to follow the procedure.



Hazards or unsafe practices which COULD result in severe personal injury or death. These instructions describe the procedure required and the injury which could result from failure to follow the procedure.



Hazards or unsafe practices which COULD result in minor personal injury or product or property damage. These instructions describe the requirements and the possible damage which could result from failure to follow the procedure.

NOTE

Instructions to aid in installation, operation, and maintenance, or which clarify a procedure.

SAFETY - SECTION A

This information applies to 0 Series engine driven pumps. Refer to the manual accompanying the engine before attempting to begin operation.

Because pump installations are seldom identical, this manual cannot possibly provide detailed instructions and precautions for each specific application. Therefore, it is the owner/installer's responsibility to ensure that applications not addressed in this manual are performed only after establishing that neither operator safety nor pump integrity are compromised by the installation.



Before attempting to open or service the pump:

1. Familiarize yourself with this manual.
2. Switch off the engine ignition, disconnect the positive battery cable and take precautions to ensure that the pump will remain inoperative.
3. Allow the pump to completely cool if overheated.
4. Check the temperature before opening any covers, plates, or plugs.
5. Close the suction and discharge valves.
6. Vent the pump slowly and cautiously.
7. Drain the pump.



This pump is designed to handle clear liquids containing specified entrained solids. Do not attempt to pump volatile, flammable or corrosive materials, or any liquids which may damage the

pump or endanger personnel as a result of pump failure.



Use lifting and moving equipment in good repair and with adequate capacity to prevent injuries to personnel or damage to equipment. Suction and discharge hoses and piping must be removed from the pump before lifting.



After the pump has been installed, make certain that the pump and all piping or hose connections are tight, properly supported and secure before operation.



Do not operate the pump against a closed discharge valve for long periods of time. If operated against a closed discharge valve, pump components will deteriorate, and the liquid could come to a boil, build pressure, and cause the pump casing to rupture or explode.



Do not remove plates, covers, gauges, pipe plugs, or fittings from an overheated pump. Vapor pressure within the pump can cause parts being disengaged to be ejected with great force. Allow the pump to cool before servicing.



Do not operate an internal combustion engine in an explosive atmosphere. When operating internal combustion

engines in an enclosed area, make certain that exhaust fumes are piped to the outside. These fumes contain carbon monoxide, a deadly gas that is colorless, tasteless, and odorless.



Fuel used by internal combustion engines presents an extreme explosion and fire hazard. Make certain that all fuel lines are securely connected and

free of leaks. Never refuel a hot or running engine. Avoid overfilling the fuel tank. Always use the correct type of fuel.



Never tamper with the governor to gain more power. The governor establishes safe operating limits that should not be exceeded. The maximum continuous operating speed for this pump is 2000 RPM.

INSTALLATION – SECTION B

Review all SAFETY information in Section A.

Since pump installations are seldom identical, this section offers only general recommendations and practices required to inspect, position, and arrange the pump and piping.

Most of the information pertains to a standard **static lift** application where the pump is positioned above the free level of liquid to be pumped.

If installed in a **flooded suction application** where the liquid is supplied to the pump under pressure, some of the information such as mounting, line

configuration, and priming must be tailored to the specific application. Since the pressure supplied to the pump is critical to performance and safety, **be sure** to limit the incoming pressure to 50% of the maximum permissible operating pressure as shown on the pump performance curve.

For further assistance, contact your Gorman-Rupp distributor or the Gorman-Rupp Company.

Pump Dimensions

See Figure 1 for the approximate physical dimensions of this pump.

OUTLINE DRAWING

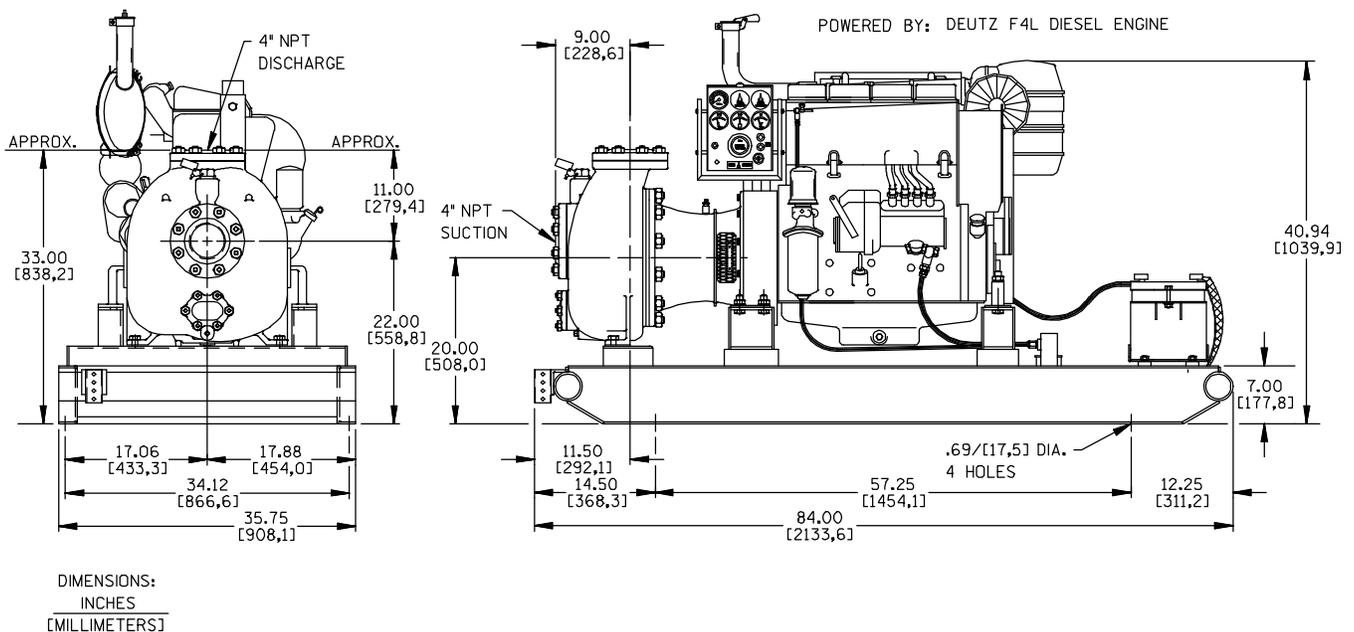

Figure 1. Pump Model 04B3-F4L

PREINSTALLATION INSPECTION

The pump assembly was inspected and tested before shipment from the factory. Before installation, inspect the pump for damage which may have occurred during shipment. Check as follows:

- a. Inspect the pump and engine for cracks, dents, damaged threads, and other obvious damage.

- b. Check for and tighten loose attaching hardware. Since gaskets tend to shrink after drying, check for loose hardware at mating surfaces.
- c. Carefully read all tags, decals, and markings on the pump assembly, and perform all duties indicated.
- d. Check levels and lubricate as necessary. Refer to **LUBRICATION** in the **MAINTENANCE**

AND REPAIR section of this manual and perform duties as instructed.

- e. If the pump and engine have been stored for more than 12 months, some of the components or lubricants may have exceeded their maximum shelf life. These **must be inspected or replaced** to ensure maximum pump service.

If the maximum shelf life has been exceeded, or if anything appears to be abnormal, contact your Gorman-Rupp distributor or the factory to determine the repair or updating policy. **Do not** put the pump into service until appropriate action has been taken.

Battery Specifications And Installation

Unless otherwise specified on the pump order, the engine battery was **not** included with the unit. Refer to the following specifications when selecting a battery.

Table 1. Battery Specifications

Voltage	Cold Crank Amps @ 0° F	Reserve Capacity @ 80° F (Minutes)	Amp/ Hr. Rating	Approx. Overall Dims. (Inches)
12 Volts	960-975	365	175	20.5L x 8.75W x 9.75H

Refer to the information accompanying the battery and/or electrolyte solution for activation and charging instructions.

Before installing the battery, clean the positive and negative cable connectors, and the battery terminals. Secure the battery by tightening the holddown brackets. The terminals and clamps may be coated with petroleum jelly to retard corrosion. Connect and tighten the positive cable first, then the negative cable.

POSITIONING PUMP



Use lifting and moving equipment in good repair and with adequate capacity to prevent injuries to personnel or dam-

age to equipment. Suction and discharge hoses and piping must be removed from the pump before lifting.

Lifting

Pump unit weights will vary depending on the mounting and drive provided. Check the shipping tag on the unit packaging for the actual weight, and use lifting equipment with appropriate capacity. Drain the pump and remove all customer-installed equipment such as suction and discharge hoses or piping before attempting to lift existing, installed units.

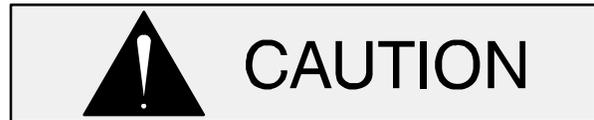

The pump assembly can be seriously damaged if the cables or chains used to lift and move the unit are improperly wrapped around the pump.

Alignment

The alignment of the pump end and engine are critical for trouble-free performance. During repair of the pump end, refer to **Securing Intermediate and Drive Assembly to Engine** in **MAINTENANCE AND REPAIR**, Section E for Details.

Mounting

Locate the pump in an accessible place as close as practical to the liquid being pumped. Level mounting is essential for proper operation.

The pump may have to be supported or shimmed to provide for level operation or to eliminate vibration.

If the pump has been mounted on a moveable base, make certain the base is stationary by setting the brake and blocking the wheels before attempting to operate the pump.

To ensure sufficient lubrication and fuel supply to the engine, **do not** position the pump and engine more than 15° off horizontal for continuous operation. The pump and engine may be positioned up to 30° off horizontal for **intermittent operation only**; however, the engine manufacturer should be consulted for continuous operation at angles greater than 15°.

SUCTION AND DISCHARGE PIPING

Pump performance is adversely effected by increased suction lift, discharge elevation, and friction losses. Contact the factory to be sure your overall application allows pump to operate within the safe operation range.

Materials

Either pipe or hose may be used for suction and discharge lines; however, the materials must be compatible with the liquid being pumped. If hose is used in suction lines, it must be the rigid-wall, reinforced type to prevent collapse under suction. Using piping couplings in suction lines is not recommended.

Line Configuration

Keep suction and discharge lines as straight as possible to minimize friction losses. Make minimum use of elbows and fittings, which substantially increase friction loss. If elbows are necessary, use the long-radius type to minimize friction loss.

Connections to Pump

Before tightening a connecting flange, align it exactly with the pump port. Never pull a pipe line into place by tightening the flange bolts and/or couplings.

Lines near the pump must be independently supported to avoid strain on the pump which could cause excessive vibration, decreased bearing life, and increased shaft and seal wear. If hose-type lines are used, they should have adequate support to secure them when filled with liquid and under pressure.

Gauges

Most pumps are drilled and tapped for installing discharge pressure and vacuum suction gauges. If these gauges are desired for pumps that are not tapped, drill and tap the suction and discharge lines not less than 18 inches from the suction and discharge ports and install the lines. Installation closer to the pump may result in erratic readings.

SUCTION LINES

To avoid air pockets which could affect pump priming, the suction line must be as short and direct as possible. When operation involves a suction lift, the line must always slope upward to the pump from the source of the liquid being pumped; if the line slopes down to the pump at any point along the suction run, air pockets will be created.

Fittings

Suction lines should be the same size as the pump inlet. If reducers are used in suction lines, they should be the eccentric type, and should be installed with the flat part of the reducers uppermost to avoid creating air pockets. Valves are not normally used in suction lines, but if a valve is used, install it with the stem horizontal to avoid air pockets.

Strainers

If a strainer is furnished with the pump, be certain to use it; any spherical solids which pass through a strainer furnished with the pump will also pass through the pump itself.

If a strainer is not furnished with the pump, but is installed by the pump user, make certain that the total area of the openings in the strainer is at least three or four times the cross section of the suction line, and that the openings will not permit passage of solids larger than the solids handling capability of the pump.

This pump is designed to handle up to 1/2-inch diameter spherical solids.

Sealing

Since even a slight leak will affect priming, head, and capacity, especially when operating with a high suction lift, all connections in the suction line should be sealed with pipe dope to ensure an airtight seal. Follow the sealant manufacturer's recommendations when selecting and applying the pipe dope. The pipe dope should be compatible with the liquid being pumped.

Suction Lines In Sumps

If a single suction line is installed in a sump, it should be positioned away from the wall of the sump at a distance equal to 1 1/2 times the diameter of the suction line.

If there is a liquid flow from an open pipe into the sump, the flow should be kept away from the suction inlet because the inflow will carry air down into the sump, and air entering the suction line will reduce pump efficiency.

If it is necessary to position inflow close to the suction inlet, install a baffle between the inflow and the suction inlet at a distance 1-1/2 times the diameter of the suction pipe. The baffle will allow entrained air to escape from the liquid before it is drawn into the suction inlet.

If two suction lines are installed in a single sump, the flow paths may interact, reducing the efficiency of one or both pumps. To avoid this, position the suction inlets so that they are separated by a distance equal to at least 3 times the diameter of the suction pipe.

Suction Line Positioning

The depth of submergence of the suction line is critical to efficient pump operation. Figure 2 shows recommended minimum submergence vs. velocity.

NOTE

The pipe submergence required may be reduced by installing a standard pipe increaser fitting at the end of the suction line. The larger opening size will reduce the inlet velocity. Calculate the required submergence using the following formula based on the increased opening size (area or diameter).

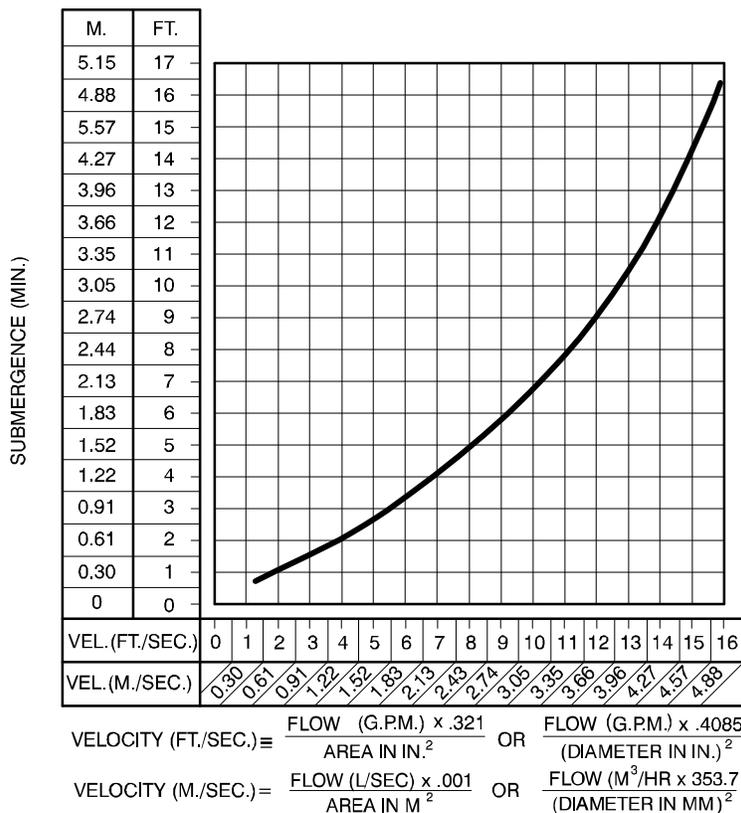

Figure 2. Recommended Minimum Suction Line Submergence vs. Velocity

FLOAT SWITCHES

Installation

The standard pump is **not** furnished with a means to automatically regulate liquid level. However, if the unit is equipped with the optional auto-start control system, the pump can be conformed to

start and stop as the liquid level in the wet well or sump rises and falls. The autostart option employs either a single or double float switch system, where a bulb raises or lowers (floats) with the liquid level, thus activating an enclosed miniature switch. The floats are equipped with a socket type connector that plugs into a matching receptacle on the auto-start control box.

Standard floats are equipped with 50 feet (15,2 m) of cable.

When installing the floats, note the following:

- a. **Be sure** to provide sufficient room in the wet well or sump so that floats do not get obstructed or drawn into the suction line. If a flexible suction hose is used, it may be extended to lay along the bottom of the wet well or sump and the float can be attached to the hose above the point where it bends along the bottom. Direct the suction line toward the flow, and the float(s) away from the flow. If a standpipe is available, attach the float switch cable to the standpipe in the sump at the approximate desired liquid level.

- b. In a single float system, the cable can be tethered to the suction line or standpipe approximately 6 inches (152 mm) above the float. This setting allows approximately 9 inches (229 mm) of liquid rise between pump start/stop. The start/stop interval may be increased by extending the float end of the cable. The liquid level in the sump will increase approximately 8 inches (203 mm) between start/stop intervals for every 6 inches (152 mm) of cable increase.
- c. If a double float switch system is used, position the "Start" float at the desired high water level in the sump, and the "Stop" float at the desired low water level in the pump.
- d. Refer to Figure 3 for additional float switch data.

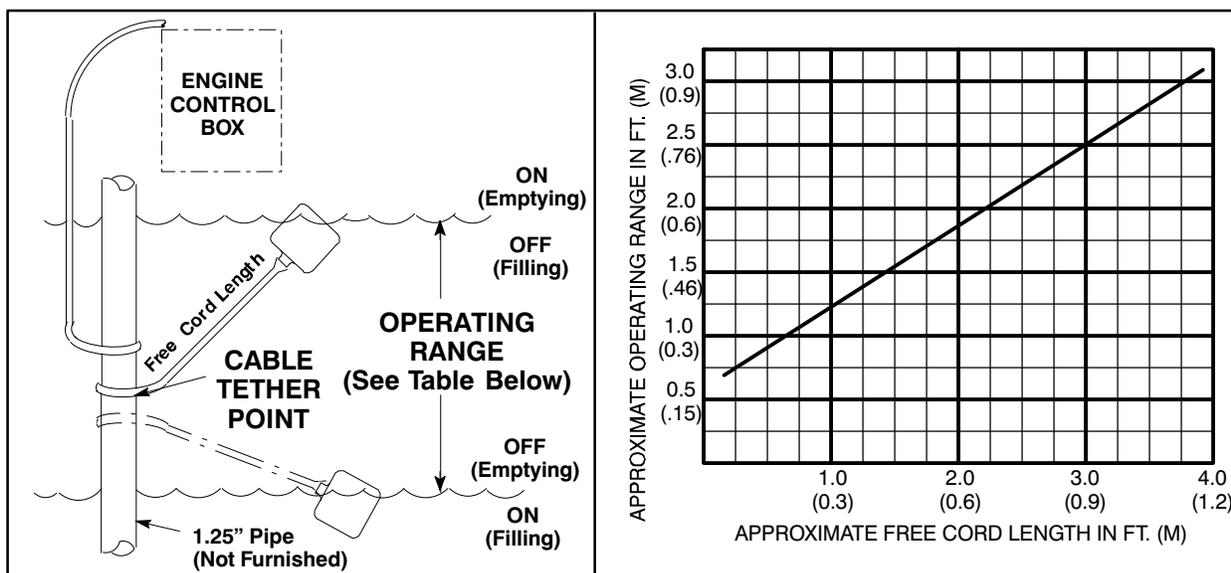

Figure 3. Float Switch Data

DISCHARGE LINES

Siphoning

Do not terminate the discharge line at a level lower than that of the liquid being pumped unless a siphon breaker is used in the line. Otherwise, a siphoning action causing damage to the pump could result.

Valves

If a throttling valve is desired in the discharge line, use a valve as large as the largest pipe to minimize friction losses. Never install a throttling valve in a suction line.

With high discharge heads, it is recommended that a throttling valve and a system check valve be installed in the discharge line to protect the pump from excessive shock pressure and reverse rotation when it is stopped.



If the application involves a high discharge head, gradually close the discharge throttling valve before stopping the pump.

Bypass Lines

If a system check valve is used due to high discharge head, it may be necessary to vent trapped

air from the top of the pump during the priming process. This may be accomplished by installing a bypass line from the top of the pump, back to the source of the liquid. The end of the bypass line must be submerged. The line must be large enough to prevent clogging, but not so large as to affect pump discharge capacity.

OPERATION – SECTION C

Review all SAFETY information in Section A.

Follow the instructions on all tags, labels and decals attached to the pump.



Do not operate an internal combustion engine in an explosive atmosphere. When operating internal combustion engines in an enclosed area, make certain that exhaust fumes are piped to the outside. These fumes contain carbon monoxide, a deadly gas that is colorless, tasteless, and odorless.



This pump is designed to handle clear liquids containing specified entrained solids. Do not attempt to pump volatile, corrosive, or flammable materials, or any liquids which may damage the pump or endanger personnel as a result of pump failure.

PRIMING

Install the pump and piping as described in **INSTALLATION**. Make sure that the piping connections are tight, and that the pump is securely mounted. Check that the pump is properly lubricated (see **LUBRICATION** in **MAINTENANCE AND REPAIR**).

This pump is self priming, but the pump should never be operated unless there is liquid in the pump casing.



Never operate this pump unless there is liquid in the pump casing. The pump will

not prime when dry. Extended operation of a dry pump will destroy the seal assembly.

Add liquid to the pump casing when:

1. The pump is being put into service for the first time.
2. The pump has not been used for a considerable length of time.
3. The liquid in the pump casing has evaporated.

When installed in a flooded suction application, simply open the system valves and permit the incoming liquid to evacuate the air. After the pump and piping system have completely filled, evacuate any remaining air pockets in the pump or suction line by loosening pipe plug or opening bleeder valves.

Once the pump casing has been filled, the pump will prime and reprime as necessary.



After filling the pump casing, reinstall and tighten the fill plug. Do not attempt to operate the pump unless all connecting piping is securely installed. Otherwise, liquid in the pump forced out under pressure could cause injury to personnel.

To fill the pump, remove the pump casing fill cover or fill plug in the top of the casing, and add clean liquid until the casing is filled. Replace the fill cover or fill plug before operating the pump.

STARTING



If the pump is equipped with the optional automatic starting system, it is subject to automatic restart. Keep hands and clothing away from the unit to pre-

vent injury during automatic operation. Disconnect the positive battery cable before performing any maintenance. Failure to do so may result in serious personal injury.

Consult the operations manual furnished with the engine.

Starting

On initial start-up, set the engine speed at the half-throttle position. Turn the keyswitch on the control box to the "START" position until the engine starts. Release the key and the switch will return to the "RUN" position.

After the engine starts and the unit is fully primed, adjust the engine RPM until the desired flow rate is achieved.



Pump speed and operating condition points must be within the continuous performance range shown on the curve on page E-1.

OPERATION

Lines With a Bypass

Close the discharge throttling valve (if so equipped) so that the pump will not have to prime against the weight of the liquid in the discharge line. Air from the suction line will be discharged through the bypass line back to the wet well during the priming cycle. When the pump is fully primed and liquid is flowing steadily from the bypass line, open the discharge throttling valve. Liquid will then continue to circulate through the bypass line while the pump is in operation.

Lines Without a Bypass

Open all valves in the discharge line and start the power source. Priming is indicated by a positive reading on the discharge pressure gauge or by a quieter operation. The pump may not prime imme-

diately because the suction line must first fill with liquid. If the pump fails to prime within five minutes, stop it and check the suction line for leaks.

After the pump has been primed, partially close the discharge line throttling valve in order to fill the line slowly and guard against excessive shock pressure which could damage pipe ends, gaskets, sprinkler heads, and any other fixtures connected to the line. When the discharge line is completely filled, adjust the throttling valve to the required flow rate.

Leakage

No leakage should be visible at pump mating surfaces, or at pump connections or fittings. Keep all line connections and fittings tight to maintain maximum pump efficiency.

Liquid Temperature And Overheating

The **maximum** liquid temperature for this pump is 160°F (71°C). Do not apply it at a higher operating temperature.

Overheating can occur if operated with the valves in the suction or discharge lines closed. Operating against closed valves could bring the liquid to a boil, build pressure, and cause the pump to rupture or explode. If overheating occurs, stop the pump and allow it to cool before servicing it. Refill the pump casing with cool liquid.



Do not remove plates, covers, gauges, pipe plugs, or fittings from an overheated pump. Vapor pressure within the pump can cause parts being disengaged to be ejected with great force. Allow the pump to cool before servicing.

Strainer Check

If a suction strainer has been shipped with the pump or installed by the user, check the strainer regularly, and clean it as necessary. The strainer should also be checked if pump flow rate begins to drop. If a vacuum suction gauge has been in-

stalled, monitor and record the readings regularly to detect strainer blockage.

Never introduce air or steam pressure into the pump casing or piping to remove a blockage. This could result in personal injury or damage to the equipment. If backflushing is absolutely necessary, **liquid pressure** must be limited to 50% of the maximum permissible operating pressure. Since this pump is fitted with a Gorman-Rupp double grease lubricated seal, the maximum incoming pressure must be reduced to 10 p.s.i.

Pump Vacuum Check

With the pump inoperative, install a vacuum gauge in the system, using pipe dope on the threads. Block the suction line and start the pump. At operating speed the pump should pull a vacuum of 20 inches (508,0 mm) or more of mercury. If it does not, check for air leaks in the seal, gasket, or discharge valve.

Open the suction line, and read the vacuum gauge with the pump primed and at operation speed. Shut off the pump. The vacuum gauge reading will immediately drop proportionate to static suction lift, and should then stabilize. If the vacuum reading falls off rapidly after stabilization, an air leak exists. Before checking for the source of the leak, check the point of installation of the vacuum gauge.

STOPPING

Stopping

In the manual mode, reduce the throttle speed slowly, and allow the engine to idle briefly before switching the HAND-OFF-AUTO switch to 'OFF'.



If the application involves a high discharge head, gradually close the discharge throttling valve before stopping the pump.

After stopping the pump, switch off the engine ignition and disconnect the positive battery cable to ensure that the pump will remain inoperative.

OPERATION

Safety Shutdown System

The unit is equipped with a safety system to automatically shut down the engine under certain conditions. The engine will automatically shut down:

1. If the engine exceeds its safe operating temperature.
2. If the engine oil pressure drops below design limits.
3. If the engine fails to start within a pre-set period of time.
4. If the engine speed exceeds the safe operating range.
5. If the engine fan belt breaks.

Lights on the control panel will indicate which of the safety features has caused the engine to shut down.

Should any of the safety features cause the engine to shut down, **the cause must be determined and corrected** before putting the unit back into service. The engine **will not restart** until the HAND-OFF-AUTO switch has been returned to the 'OFF' position for at least 10 seconds.

All safety shutdown features are pre-set at the factory for optimum performance and safety; **do not** attempt to adjust these settings.



Never disconnect any of the safety shutdown features; this will void the warranty and could result in serious damage to the unit and/or injury to personnel. Safety shutdown features are pre-set at the factory; do not attempt to adjust any of the settings. Determine the cause of shutdown before putting the unit back into service. Consult the factory for additional information.

OPERATION IN EXTREME HEAT

The safety shutdown system will automatically stop the unit if engine operating temperature ex-

ceeds design limits. If engine over-temperature shutdown occurs, allow the unit to cool before re-starting.

If engine overheating continues, check the engine lubricant level and viscosity. Consult the engine operation manual for the recommended lubricant for operation in extreme heat.

If the unit is equipped with the optional auto-start control, the float(s) may need to be adjusted to allow shorter run and longer cooling periods, if possible.



If the pump is equipped with the optional automatic starting system, it is subject to automatic restart. Keep hands and clothing away from the unit to prevent injury during automatic operation. Disconnect the battery before performing any maintenance. Failure to do so may result in serious personal injury.

BEARING TEMPERATURE CHECK

Bearings normally run at higher than ambient temperatures because of heat generated by friction. Temperatures up to 160°F (71°C) are considered normal for bearings, and they can operate safely to at least 180°F (82°C).

Checking bearing temperatures by hand is inaccurate. Bearing temperatures can be measured accurately by placing a contact-type thermometer against the housing. Record this temperature for future reference.

A sudden increase in bearing temperatures is a warning that the bearings are at the point of failing to operate properly. Make certain that the bearing lubricant is of the proper viscosity and at the correct level (see **LUBRICATION** in Section E). Bearing overheating can also be caused by shaft misalignment and/or excessive vibration.

When pumps are first started, the bearings may seem to run at temperatures above normal. Continued operation should bring the temperatures down to normal levels.

Cold Weather Preservation

In below freezing conditions, drain the pump to prevent damage from freezing. Also, clean out any solids by flushing with a hose. Operate the pump for approximately one minute; this will remove any remaining liquid that could freeze the pump rotating parts. If the pump will be idle for more than a few hours, or if it has been pumping liquids containing a large amount of solids, drain the pump, and flush it thoroughly with clean water. To prevent large solids from clogging the drain port and preventing the pump from completely draining, insert a rod or stiff wire in the drain port, and agitate the liquid during the draining process. Clean out any remaining solids by flushing with a hose.

TROUBLESHOOTING – SECTION D

Review all SAFETY information in Section A.



Before attempting to open or service the pump:

1. Familiarize yourself with this manual.
2. Switch off the engine ignition, disconnect the positive battery cable and take precautions to ensure that the pump will remain inoperative.
3. Allow the pump to completely cool if overheated.
4. Check the temperature before opening any covers, plates, or plugs.
5. Close the suction and discharge valves.
6. Vent the pump slowly and cautiously.
7. Drain the pump.

TROUBLE	POSSIBLE CAUSE	PROBABLE REMEDY
PUMP FAILS TO PRIME	<p>Not enough liquid in casing.</p> <p>Suction check valve contaminated or damaged.</p> <p>Air leak in suction line.</p> <p>Lining of suction hose collapsed.</p> <p>Leaking or worn seal or pump gasket.</p> <p>Suction lift or discharge head too high.</p> <p>Strainer clogged.</p> <p>Suction check valve or foot valve clogged or binding.</p>	<p>Add liquid to casing. See PRIMING.</p> <p>Clean or replace check valve.</p> <p>Correct leak.</p> <p>Replace suction hose.</p> <p>Check pump vacuum. Replace leaking or worn seal or gasket.</p> <p>Check piping installation and install bypass line if needed. See INSTALLATION.</p> <p>Check strainer and clean if necessary.</p> <p>Clean valve.</p>
PUMP STOPS OR FAILS TO DELIVER RATED FLOW OR PRESSURE	<p>Air leak in suction line.</p> <p>Lining of suction hose collapsed.</p> <p>Leaking or worn seal or pump gasket.</p> <p>Strainer clogged.</p>	<p>Correct leak.</p> <p>Replace suction hose.</p> <p>Check pump vacuum. Replace leaking or worn seal or gasket.</p> <p>Check strainer and clean if necessary.</p>

TROUBLE	POSSIBLE CAUSE	PROBABLE REMEDY
PUMP STOPS OR FAILS TO DELIVER RATED FLOW OR PRESSURE (cont.)	<p>Suction intake not submerged at proper level or sump too small.</p> <p>Impeller or other wearing parts worn or damaged.</p> <p>Impeller clogged.</p> <p>Pump speed too slow.</p> <p>Suction lift or discharge head too high.</p>	<p>Check installation and correct submergence as needed.</p> <p>Replace worn or damaged parts. Check that impeller is properly centered and rotates freely.</p> <p>Free impeller of debris.</p> <p>Check engine output; consult engine operation manual.</p> <p>Check piping installation and install bypass line if needed. See INSTALLATION.</p>
PUMP REQUIRES TOO MUCH POWER	<p>Pump speed too high.</p> <p>Discharge head too low.</p> <p>Liquid solution too thick.</p> <p>Bearing(s) frozen.</p>	<p>Check engine output.</p> <p>Adjust discharge valve.</p> <p>Dilute if possible.</p> <p>Disassemble pump and check bearing(s).</p>
PUMP CLOGS FREQUENTLY	<p>Liquid solution too thick.</p> <p>Discharge flow too slow.</p> <p>Discharge line clogged or restricted; hose kinked.</p> <p>Suction check valve or foot valve clogged or binding.</p>	<p>Dilute if possible.</p> <p>Open discharge valve fully to increase flow rate, and run power source at maximum governed speed.</p> <p>Check discharge lines; straighten hose.</p> <p>Clean valve.</p>
EXCESSIVE NOISE	<p>Cavitation in pump.</p> <p>Pumping entrained air.</p> <p>Pump or drive not securely mounted.</p> <p>Impeller clogged or damaged.</p>	<p>Reduce suction lift and/or friction losses in suction line. Record vacuum and pressure gauge readings and consult local representative or factory.</p> <p>Locate and eliminate source of air bubble.</p> <p>Secure mounting hardware.</p> <p>Clean out debris; replace damaged parts.</p>
BEARINGS RUN TOO HOT	<p>Bearing temperature is high, but within limits.</p> <p>Low or incorrect lubricant</p> <p>Suction and discharge lines not properly supported.</p> <p>Drive misaligned.</p>	<p>Check bearing temperature regularly to monitor any increase.</p> <p>Check for proper type and level of lubricant.</p> <p>Check piping installation for proper support.</p> <p>Align drive properly.</p>

PREVENTIVE MAINTENANCE

Since pump applications are seldom identical, and pump wear is directly affected by such things as the abrasive qualities, pressure and temperature of the liquid being pumped, this section is intended only to provide general recommendations and practices for preventive maintenance. Regardless of the application however, following a routine preventive maintenance schedule will help assure trouble-free performance and long life from your Gorman-Rupp pump. For specific questions concerning your application, contact your Gorman-Rupp distributor or the Gorman-Rupp Company.

Record keeping is an essential component of a good preventive maintenance program. Changes in suction and discharge gauge readings (if so

equipped) between regularly scheduled inspections can indicate problems that can be corrected before system damage or catastrophic failure occurs. The appearance of wearing parts should also be documented at each inspection for comparison as well. Also, if records indicate that a certain part (such as the seal) fails at approximately the same duty cycle, the part can be checked and replaced before failure occurs, reducing unscheduled down time.

For new applications, a first inspection of wearing parts at 250 hours will give insight into the wear rate for your particular application. Subsequent inspections should be performed at the intervals shown on the chart below. Critical applications should be inspected more frequently.

Preventive Maintenance Schedule					
Item	Service Interval*				
	Daily	Weekly	Monthly	Semi-Annually	Annually
General Condition (Temperature, Unusual Noises or Vibrations, Cracks, Leaks, Loose Hardware, Etc.)	I				
Pump Performance (Gauges, Speed, Flow)	I				
Bearing Lubrication		I			R
Seal Lubrication (And Packing Adjustment, If So Equipped)		I			R
V-Belts (If So Equipped)			I		
Air Release Valve Plunger Rod (If So Equipped)			I	C	
Front Impeller Clearance (Wear Plate)				I	
Rear Impeller Clearance (Seal Plate)				I	
Check Valve					I
Pressure Relief Valve (If So Equipped)					C
Pump and Driver Alignment					I
Shaft Deflection					I
Bearings					I
Bearing Housing					I
Piping					I
Driver Lubrication – See Mfgr’s Literature					I

Legend:
 I = Inspect, Clean, Adjust, Repair or Replace as Necessary
 C = Clean
 R = Replace

* Service interval based on an intermittent duty cycle equal to approximately 4000 hours annually. Adjust schedule as required for lower or higher duty cycles or extreme operating conditions.

PUMP MAINTENANCE AND REPAIR - SECTION E

MAINTENANCE AND REPAIR OF THE WEARING PARTS OF THE PUMP WILL MAINTAIN PEAK OPERATING PERFORMANCE.

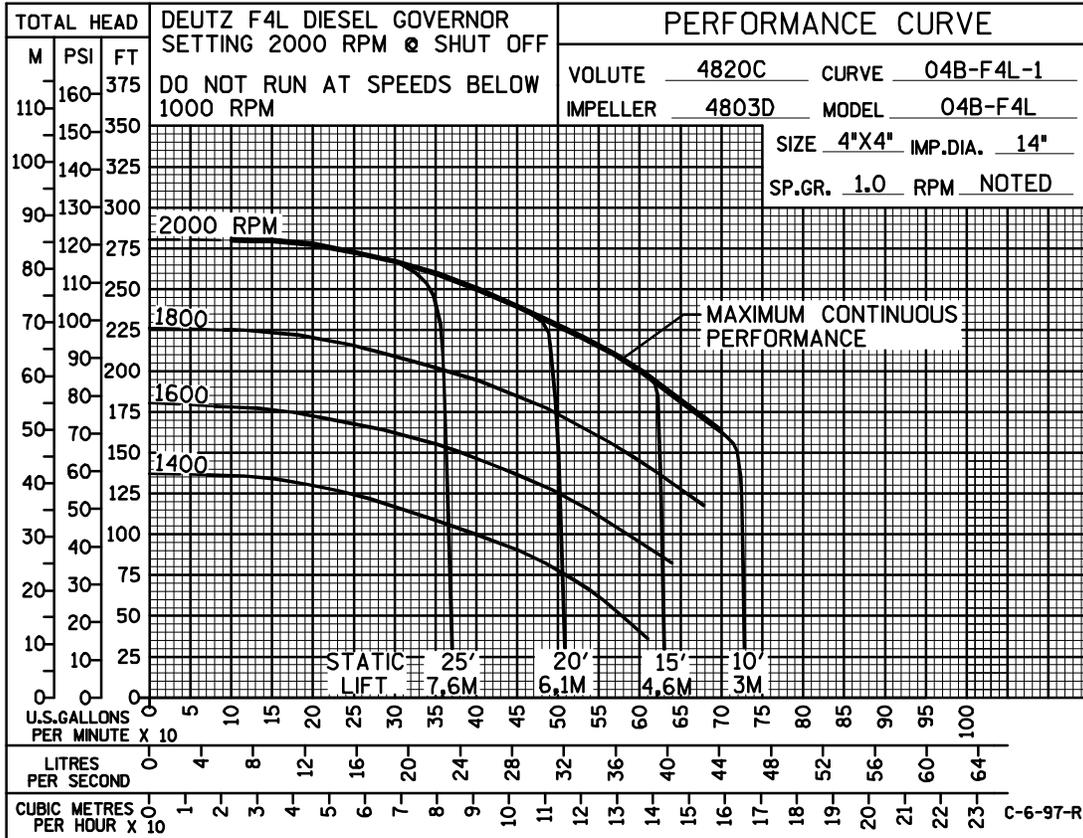

* STANDARD PERFORMANCE FOR PUMP MODEL 04B3-F4L

* Based on 70°F (21°C) clear water at sea level with minimum suction lift. Since pump installations are seldom identical, your performance may be difference due to such factors as viscosity, specific gravity, elevation, temperature, and impeller trim.

If your pump serial number is followed by an "N", your pump is **NOT** a standard production model. Contact the Gorman-Rupp Company to verify performance or part numbers.



WARNING!

Never tamper with the governor to gain more power. The governor establishes safe operating limits that should not be exceeded. The maximum continuous operating speed for this pump is 2000 RPM.

SECTION DRAWING

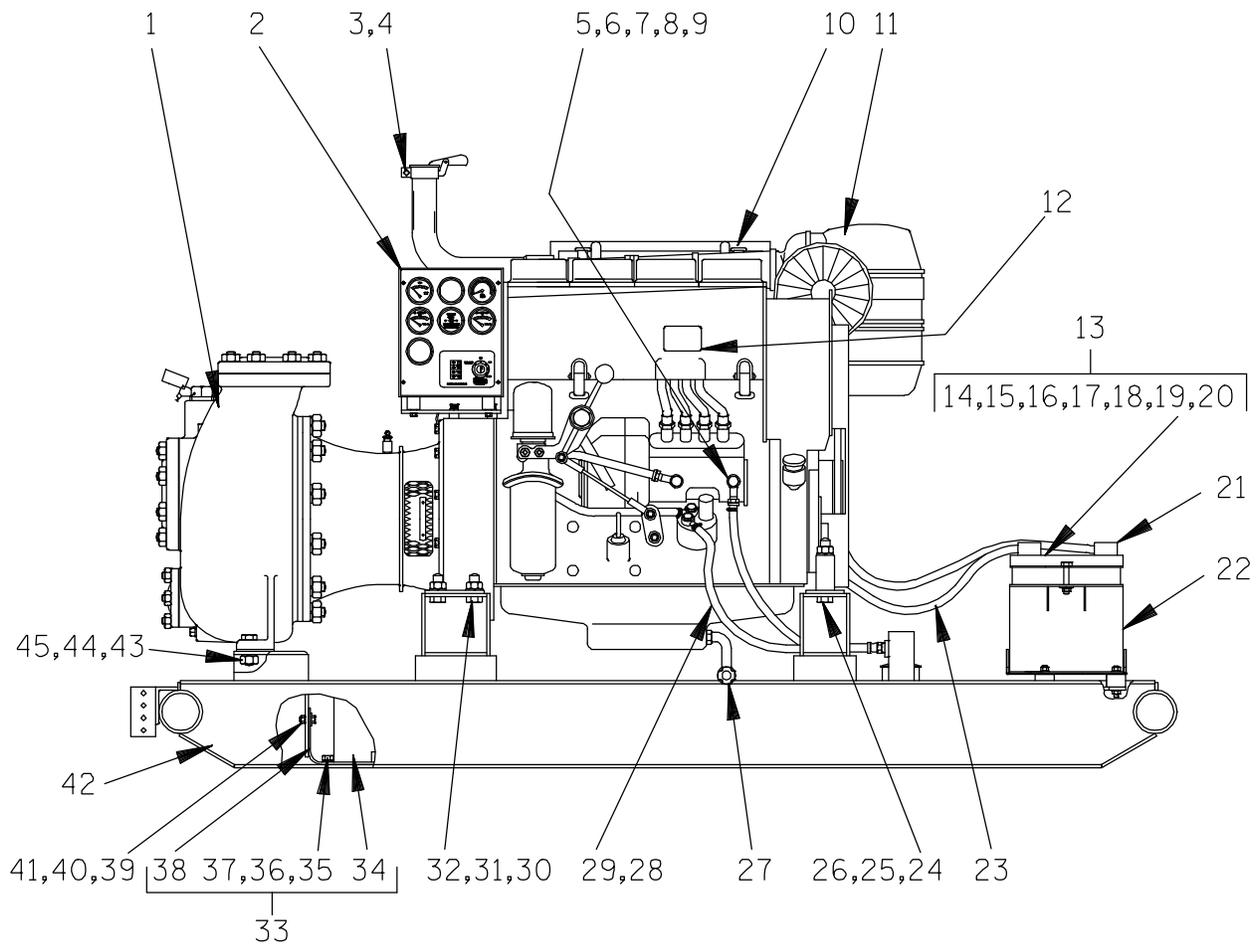

Figure 1. 04B3-F4L Pump Model Assembly

SECTION DRAWING

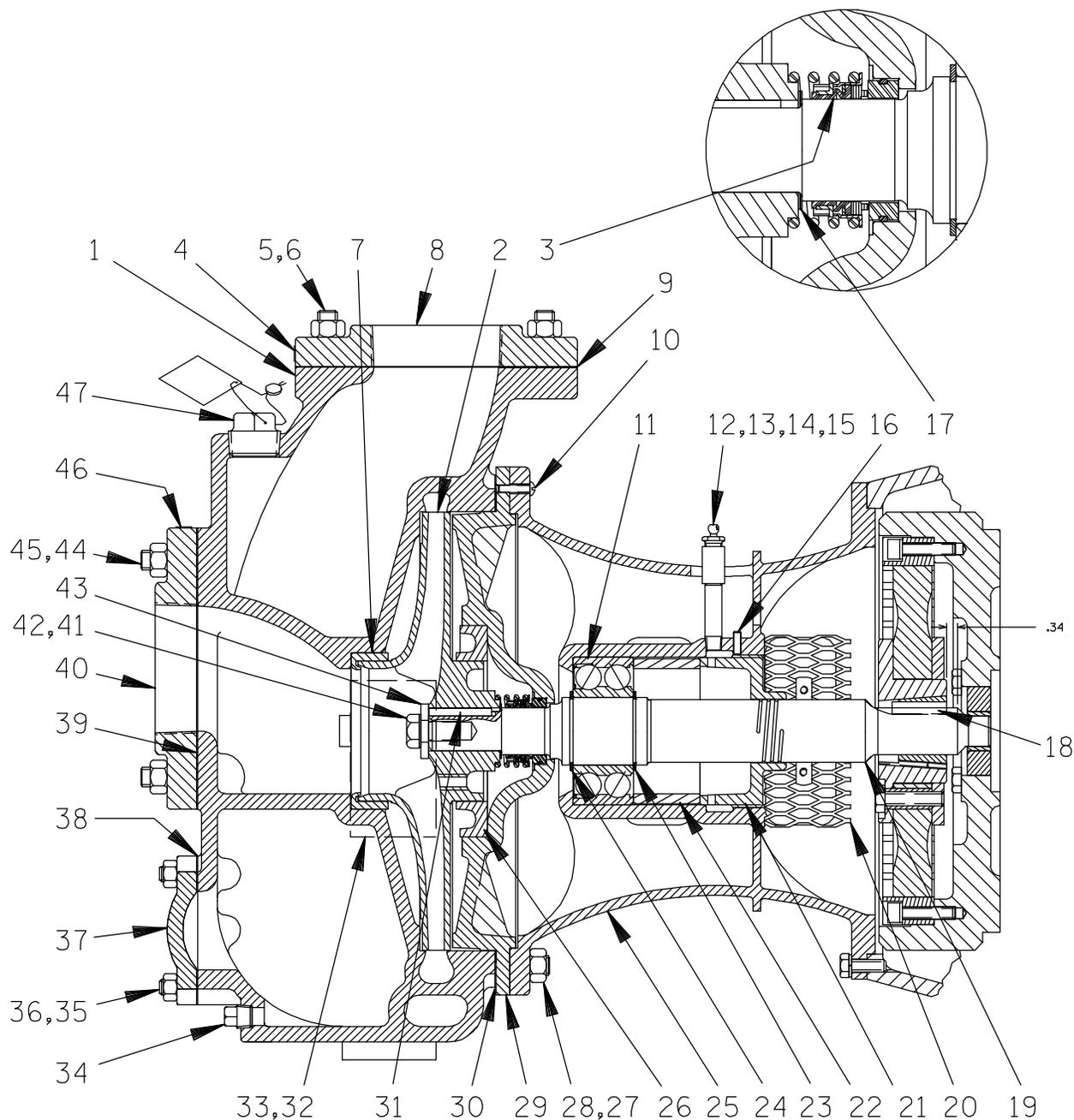

Figure 2. 04B3-(SAE 4/10) Pump End Assembly

PARTS LIST
04B3-(SAE 4/10) Pump End Assembly

ITEM NO.	PART NAME	PART NUMBER	MAT'L CODE	QTY	ITEM NO.	PART NAME	PART NUMBER	MAT'L CODE	QTY
1	PUMP CASING	4820C	10010	1	26 *	WEAR RING	6902	10010	1
2 *	IMPELLER	4803D	14000	1	27	STUD	C1010	15991	12
3 *	SEAL ASSY	25271-207	----	1	28	HEX NUT	D10	15991	12
4	DISCHARGE STICKER	6588BJ	----	1	29	SEAL PLATE	5792	10010	1
5	STUD	C1010	15991	8	30 *	PUMP CASING GASKET	4820G	20000	1
6	HEX NUT	D10	15991	8	31 *	IMPELLER KEY	N0408	15990	1
7 *	WEAR RING	3765A	10010	1	32	NAME PLATE	38818-018	13990	1
8	DISCHARGE FLANGE	1756	10010	1	33	DRIVE SCREW	BM#04-03	17000	4
9 *	DISCH FLANGE GASKET	1676GB	20000	1	34	PIPE PLUG	P06	15079	1
10	RD HD MACH SCREW	X0404	15991	2	35	STUD	C0807	15991	6
11 *	BALL BEARING	23423-472	----	1	36	HEX NUT	D08	15991	6
12	LUBE FITTING	S191	----	1	37	COVER PLATE	4822	10010	1
13	PIPE NIPPLE	T0410	15079	1	38 *	COVER PLATE GASKET	4822G	20000	1
14	PIPE COUPLING	AE04	15079	1	39 *	SUCT FLANGE GASKET	1676GB	20000	1
15	CAP PLUG	25141-151	----	1	40	SUCTION FLANGE	1756	10010	1
16	ALLEN HD SETSCREW	GA0403	15990	1	41	HEX HD CAPSCREW	B1005S	15991	1
17 *	IMP ADJ SHIM SET	37J	17090	REF	42	T TYPE LOCKWASHER	AK10	15991	1
18 *	SHAFT KEY	N0607	15990	1	43	IMPELLER WASHER	5718	15990	1
19 *	IMPELLER SHAFT	38517-517	1706H	1	44	HEX HD CAPSCREW	C1010	15991	8
20	INTERMEDIATE GUARD	42381-504	----	2	45	HEX NUT	D10	115991	8
21	BEARING RET NUT	4329	10010	1	46	DISCHARGE STICKER	6588AG	----	1
22	SPACER	13886	15990	1	47	FILL PLUG ASSY	48271-065	----	1
23	RETAINING RING	S215	----	1	NOT SHOWN:				
24	RETAINING RING	S215	----	1		INSTRUCTION TAG	38817-085	----	1
25	INTERMEDIATE	7765D	10010	1		LUBE DECAL	38816-075	----	1
						PRIMING STICKER	6588AH	----	1

* INDICATES PARTS RECOMMENDED FOR STOCK

SECTION DRAWING

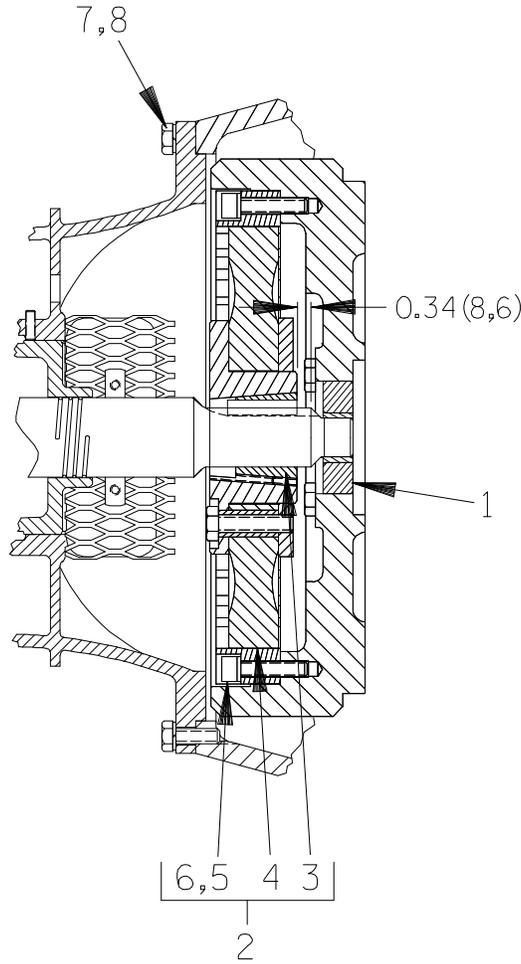

Figure 3. 04B3-(SAE 4/10) Drive Assembly

PARTS LIST

ITEM NO.	PART NAME	PART NUMBER	MAT'L CODE	QTY
1	PILOT BUSHING ASSY	44144-003	---	1
2	COUPLING KIT	48112-001	---	1
3	-BUSHING	24131-345	---	1
4	-COUPLING ASSEMBLY	44165-011	---	1
5	 -LOCK WASHER	J06	15991	8
5	 -LOCKWASHER	21171-536	---	8
6	 -SOCKET HD CAPSCREW	BD0606-1/2	15991	8
6	 -SOCKET HD CAPSCREW	22644-220	---	8
7	 HEX HD CAPSCREW	B0605	15991	12
7	 HEX HD CAPSCREW	22645-164	---	12
8	 LOCK WASHER	J06	15991	12
8	 LOCKWASHER	21171-511	---	12

 USE FOR SAE APPLICATIONS

 USE FOR METRIC APPLICATIONS

PUMP AND SEAL DISASSEMBLY AND REASSEMBLY

Review all SAFETY information in Section A.

Follow the instructions on all tags, label and decals attached to the pump.

This pump requires little service due to its rugged, minimum-maintenance design. However, if it becomes necessary to inspect or replace the wearing parts, follow these instructions which are keyed to the sectional views (see Figures 1, 2 and 3) and the accompanying parts lists.

This manual will alert personnel to known procedures which require special attention, to those which could damage equipment, and to those which could be dangerous to personnel. However, this manual cannot possibly anticipate and provide detailed precautions for every situation that might occur during maintenance of the unit. Therefore, it is the responsibility of the owner/maintenance personnel to ensure that **only** safe, established maintenance procedures are used, and that any procedures not addressed in this manual are performed **only** after establishing that neither personal safety nor pump integrity are compromised by such practices.

Before attempting to service the pump, switch off the engine ignition and disconnect the positive battery cable to ensure that the pump will remain inoperative. Close all valves in the suction and discharge lines.

For engine disassembly and repair, consult the literature supplied with the engine, or contact your local engine representative.



Before attempting to open or service the pump:

1. **Familiarize yourself with this manual.**
2. **Switch off the engine ignition and disconnect the positive battery cable to ensure that the pump will remain inoperative.**

3. **Allow the pump to completely cool if overheated.**
4. **Check the temperature before opening any covers, plates, or plugs.**
5. **Close the suction and discharge valves.**
6. **Vent the pump slowly and cautiously.**
7. **Drain the pump.**

Pump Disassembly

(Figure 2)

Before attempting to service the pump, remove the pump casing drain plug (34) and drain the pump. Clean and reinstall the drain plug.

To service the wear ring (7), impeller (2), seal assembly (3), or seal plate (29), the pump casing (1) must be separated from the base and intermediate (25).

Remove the suction and discharge lines. See Figure 1, and remove the hardware (45, 46 and 47) securing the casing to the base (44). Remove the nuts (28) and use a suitable hoist and sling to separate the pump casing and gasket (30) from the seal plate and intermediate.



Use lifting and moving equipment in good repair and with adequate capacity to prevent injuries to personnel or damage to equipment. Suction and discharge hoses and piping must be removed from the pump before lifting.

Tie and tag any leveling shims used under the casing feet to ease reassembly.

Inspect the wear ring (7) for excessive wear or scoring. The wear ring is secured in the pump casing by a press fit. If replacement is required, use a small bit to drill two holes through the ring horizontally, 180° apart. Use a saw or chisel to complete the cuts through the ring, and remove it from the pump casing. **Use caution** not to damage the pump casing bore when removing the wear ring.



Use caution not to damage the pump casing bore when removing the wear ring.

Impeller Removal

(Figure 2)

To remove the impeller (2), disengage the hardware (41, 42 and 43). Install 3/8-16 UNC by 4-inch long capscrews in the tapped holes in the impeller. Use the capscrews and a suitable puller to remove the impeller from the shaft. Use caution when removing the impeller; tension on the seal spring will be released as the impeller is removed. Retain the impeller key (31).

Remove the impeller adjusting shims (17). Tie and tag the shims or measure and record their thickness for ease of reassembly.

Seal Removal and Disassembly

(Figures 2 and 5)

Remove the spring. Apply oil to the shaft and work it up under the rubber bellows. Slide the rotating portion of the seal off the shaft.

Remove the round head machine screws (10) and slide the seal plate and stationary element off the impeller shaft as a unit. Press the stationary seal element and O-ring out of the seal plate from the back side.

Inspect the wear ring (26) for excessive wear or damage. If replacement is required, use a suitable puller to remove it from the seal plate.

Separating Intermediate and Drive Assembly From Engine

(Figure 2)

To service the shaft (19), bearing (11) or drive assembly, the intermediate (25) must be separated from the engine.

(Figure 3)

Support the intermediate using a hoist and sling, and remove the hardware (7 and 8) securing it to the engine bellhousing. Separate the assemblies by pulling the intermediate straight away from the engine.

As the assemblies separate, the flexible portion of the coupling assembly (4) will remain on the shaft. To remove the coupling from the shaft, unscrew the two allen head setscrews from the bushing (3). Screw one of the setscrews into the puller hole on the circumference of the bushing. As the coupling and bushing separate, remove the bushing, and slide the coupling off the shaft. Remove the shaft key (18, Figure 2).

It is not necessary to remove the outer ring of the coupling from the engine flywheel unless the coupling must be replaced. To remove the ring, disengage the hardware (5 and 6) securing it to the flywheel.

Inspect the pilot bushing (1) for excessive wear. If replacement is required, it can be easily removed from the engine flywheel by making a hydraulic ram from a piece of steel bar stock. Turn the ram to a diameter of 0.983 inch (25 mm).



When performing the following procedure, grease can be ejected with great force. Wear safety glasses or goggles to prevent injury.

Completely pack the bore of the pilot bushing with grease. Insert the end of the ram into the I.D. of the bushing. Strike the ram sharply with a hammer, compressing the grease, and forcing the bushing out of the flywheel. Use additional grease as required, and continue to strike the ram until the bushing is completely free.

Shaft and Bearing Removal and Disassembly

(Figure 2)

When the pump is properly operated and maintained, the shaft and bearing should not require disassembly. Disassemble the shaft and bearing **only** when there is evidence of wear or damage.



CAUTION

Shaft and bearing disassembly in the field is not recommended. These operations should be performed only in a properly equipped shop by qualified personnel.

After separating the intermediate from the engine, loosen the allen head setscrew (16) and unscrew the bearing retainer nut (21) from the intermediate.

NOTE

There are no provisions for draining the grease from the intermediate cavity. Place a drip pan under the intermediate before removing the shaft and bearing.

Place a block of wood against the impeller end of the shaft (19) and tap the shaft, spacer (22) and bearing (11) from the bearing bore.

After removing the shaft and bearing, clean and inspect the bearing **in place** as follows.



CAUTION

To prevent damage during removal from the shaft, it is recommended that the bearing be cleaned and inspected **in place**. It is **strongly** recommended that the bearing be replaced **any** time the shaft and bearing are removed.

Clean the intermediate, shaft and all component parts (except the bearing) with a soft cloth soaked in cleaning solvent. Inspect the parts for wear or damage and replace as necessary.



WARNING!

Most cleaning solvents are toxic and flammable. Use them only in a well ventilated area free from excessive heat, sparks, and flame. Read and follow all precautions printed on solvent containers.

Clean the bearing thoroughly in **fresh** cleaning solvent. Dry the bearing with filtered compressed air and coat with light oil.



CAUTION

The bearing must be kept free of all dirt and foreign material. Failure to do so will greatly shorten bearing life. **Do not** spin dry bearings. This may scratch the balls or races and cause premature bearing failure.

Rotate the bearing by hand to check for roughness or binding and inspect the bearing balls. If rotation is rough or the bearing balls are discolored, replace the bearing.

The bearing tolerances provide a tight press fit onto the shaft and a snug slip fit into the intermediate. Replace the bearing, shaft, or intermediate if the proper bearing fit is not achieved.

Remove the inboard bearing retaining ring (24) and using an arbor (or hydraulic) press remove the bearing (11) from the shaft. It is not necessary to remove the outboard bearing retaining ring (23) from the shaft unless replacement is required. Remove the bearing spacer (22).

Shaft and Bearing Reassembly and Installation

Clean and inspect the bearing as indicated in **Shaft and Bearing Removal and Disassembly**.



CAUTION

To prevent damage during removal from the shaft, it is recommended that the bearing be cleaned and inspected **in place**. It is **strongly** recommended that the bearing be replaced **any** time the shaft and bearings are removed.

Inspect the shaft for distortion, nicks or scratches or damage. Dress small nicks and burrs with a fine file or emery cloth. Replace the shaft if defective.

Install the outboard bearing retaining ring (23) if it was removed. Replace the bearing spacer (22).

NOTE

If a hot oil bath is used to heat the bearing, both the oil and the container must be **absolutely clean**. If the oil has been previously used, it must be **thoroughly filtered**.

The bearing may be heated to ease installation. An induction heater, hot oil bath, electric oven, or hot plate may be used to heat the bearing. Bearings should **never** be heated with a direct flame or directly on a hot plate.

NOTE

Position the bearing on the shaft as indicated in Figure 4.

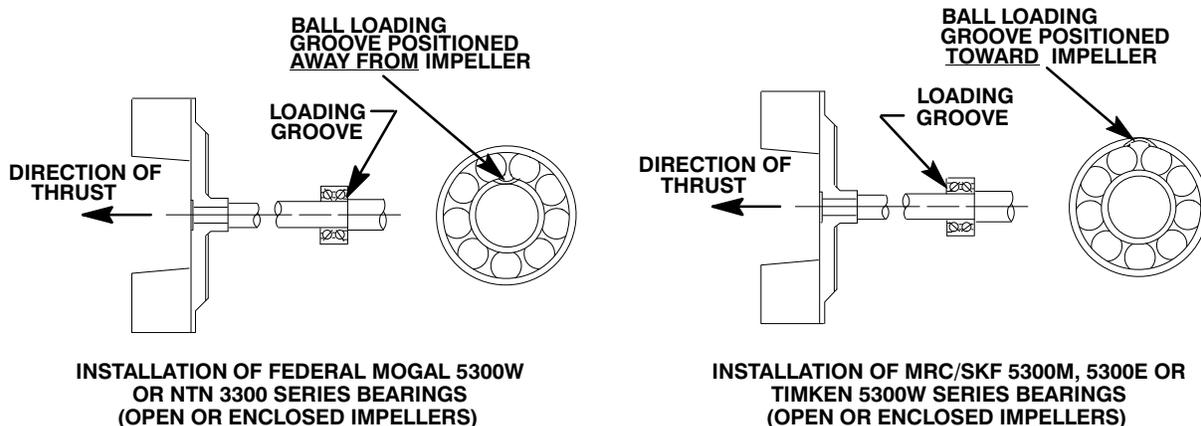

Figure 4. Bearing Positioning

After the bearing has been installed and allowed to cool, check to ensure that it has not moved in shrinking. If movement has occurred, use a suitable sized sleeve and a press to reposition the bearing.

If heating the bearing is not practical, use a suitable sized sleeve and an arbor (or hydraulic) press to install the bearing on the shaft.



When installing the bearing on the shaft, **never** press or hit against the outer race, balls, or ball cage. Press **only** on the inner race.

Pack the bearing by hand with No. 0 lithium based grease until the bearing balls are thoroughly lubri-

Heat the bearing to a uniform temperature **no higher than 250°F (120°C)**, and slide the bearing onto the shaft until fully seated against the bearing spacer. This should be done quickly, in one continuous motion, to prevent the bearing from cooling and sticking on the shaft.



Use caution when handling hot bearings to prevent burns.

cated. Secure the bearing on the shaft with the in-board bearing retaining ring (24).

Slide the shaft and assembled bearing into the intermediate bore from the drive end until the bearing seats squarely against the bore shoulder.



When installing the shaft and bearing into the bearing bore, push against the outer race. **Never** hit the balls or ball cage.

Install the spacer (22) in the intermediate. Pack the intermediate with 2/3 lb. (0.3 kg.) of No. 0 lithium based grease (approximately 1/3 full).

Screw the bearing retaining nut (21) into the intermediate and check the shaft endplay. Adjust the bearing retaining nut to establish the correct

endplay, and secure the bearing retaining nut with the setscrew (16).

NOTE

Impeller shaft endplay should be between .002 and .010 inch (0,05 mm to 0,25 mm). Adjust the bearing retaining nut to obtain the correct endplay.

Securing Intermediate and Drive Assembly To Engine

(Figure 3)

If removed, apply a thin coating of 'Never-Seez' (or equivalent) lubricant to the inside diameter of the replacement pilot bushing (1) and press it into the flywheel until fully seated.

Install the shaft key (18, Figure 2) in the shaft keyway. Position the flexible portion of the coupling assembly (4) on the shaft as shown in Figure 3.

NOTE

*The flexible portion of the coupling must be properly positioned on the shaft. The heads of the capscrews in the center of the coupling **must be positioned toward the pump end of the shaft.***

Align the keyway in the bushing (3) with the shaft key, and slide it onto the shaft to the dimension shown in Figure 3.

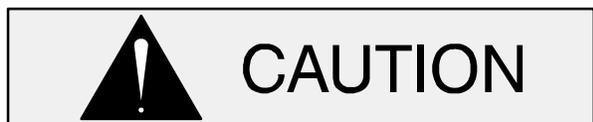

Make certain that the flexible portion of the coupling is mounted as shown in Figure 3. **This is critical.** If the coupling is not properly positioned on the shaft, the coupling parts may not fully engage, or a pre-load condition can cause premature bearing failure.

The flexible portion of the coupling, shaft key and bushing **must** be positioned on the shaft to the dimension shown in Figure 3. This will allow the two portions of the coupling to fully engage when the intermediate is secured to the engine bellhousing,

without pre-loading the bearing or pilot bushing.

Rotate the flexible portion of the coupling until the tapped holes for the two setscrews align with those in the bushing, and install the setscrews.

With the flexible portion of the coupling and the bushing properly positioned on the shaft, tighten the two setscrews in an alternating sequence until the bushing and coupling are fully secured. Torque the setscrews to 175 in. lbs. (2 m. kg.).

If the complete coupling assembly is being replaced, apply 'Loctite Retaining Compound No. 242' or equivalent compound to the threads of the hardware (5 and 6), and secure the outer ring of the coupling to the engine flywheel by torquing the hardware to 45 ft. lbs. (540 in. lbs. or 6,2 m. kg.).

Using a suitable lifting device, position the assembled intermediate and flexible portion of the coupling so the coupling seats inside the outer ring attached to the engine flywheel.

NOTE

*To ease installation, **lightly** lubricate the rubber portion of the coupling with a **non-petroleum based lubricant** such as vegetable oil or glycerin, or a silicon-based lubricant such as "WD40" or equivalent. **Do not** use petroleum-based lubricants, or any other substance which may soften or otherwise damage the rubber.*

Secure the intermediate to the engine bellhousing with the previously removed hardware (7 and 8).

Seal Reassembly and Installation

(Figures 2 and 5)

Clean the seal cavity and shaft with a cloth soaked in fresh cleaning solvent.



Most cleaning solvents are toxic and flammable. Use them only in a well ventilated area free from excessive heat, sparks, and flame. Read and follow all precautions printed on solvent containers.

The seal is not normally reused because wear patterns on the finished faces cannot be realigned during reassembly. This could result in premature failure. If necessary to reuse an old seal in an emergency, **carefully** wash all metallic parts in fresh cleaning solvent and allow to dry thoroughly.

Handle the seal parts with extreme care to prevent damage. Be careful not to contaminate precision finished faces; even fingerprints on the faces can shorten seal life. If necessary, clean the faces with a non-oil based solvent and a clean, lint-free tissue. Wipe **lightly** in a concentric pattern to avoid scratching the faces.

Inspect the seal components for wear, scoring, grooves, and other damage that might cause leakage. If any components are worn, replace the complete seal; **never mix old and new seal parts.**

If a replacement seal is being used, remove it from the container and inspect the precision finished faces to ensure that they are free of any foreign matter.

To ease installation of the seal, lubricate the bellows and O-rings with water or a very **small** amount of light lubricating oil, and apply a drop of light lubricating oil on the finished faces. Assemble the seal as follows, (see Figure 5).

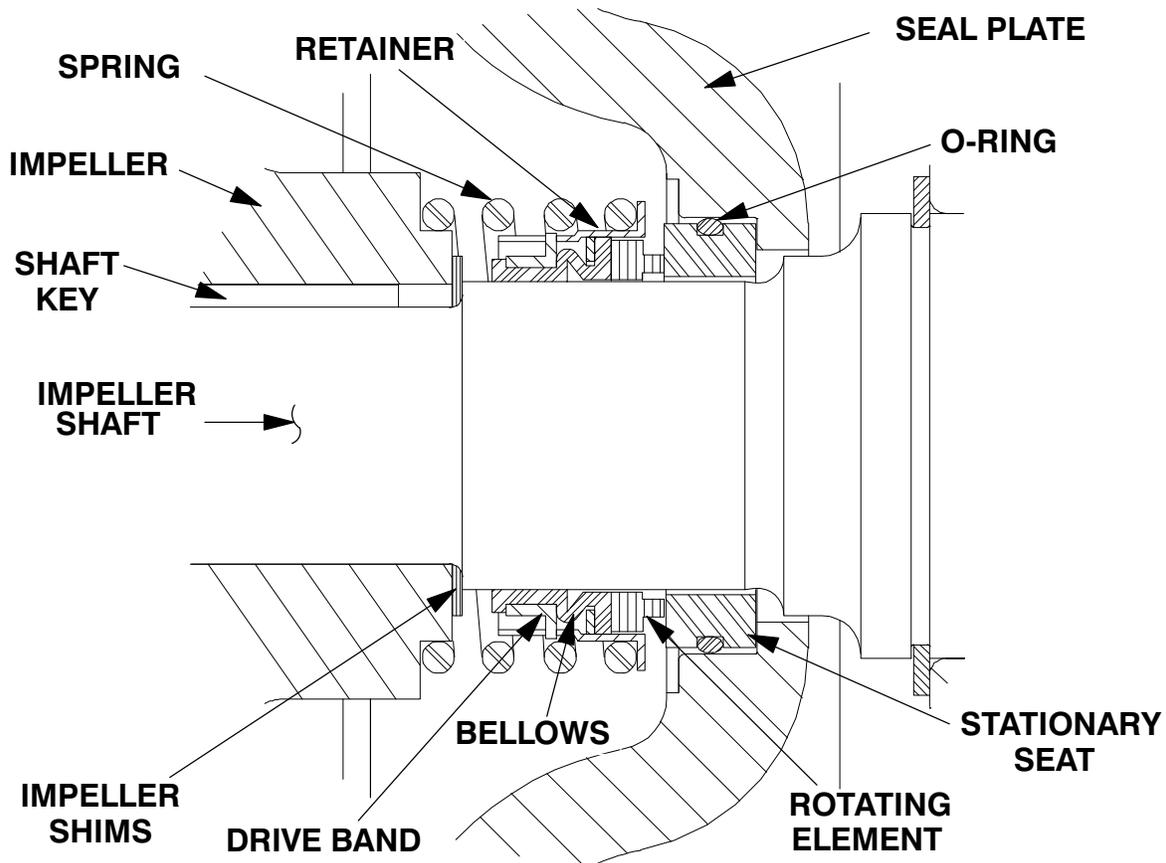

Figure 5. 25271-207 Seal Assembly



This seal is not designed for operation at temperatures above 160°F (71°C). Do not use at higher operating temperatures.

Lay the seal plate (29) on a flat surface with the impeller side facing up. If the wear ring (26) was removed, press the replacement ring into the seal

plate until it seats squarely against the bore shoulder.



The wear ring **must** seat squarely in the seal plate bore or binding and/or excessive wear will result.

Subassemble the O-ring onto the stationary element and use even pressure to press this subassembly into the seal plate until it seats squarely against the shoulder bore

Carefully slide the assembled seal plate and stationary seal element over the shaft. Secure the seal plate to the intermediate with the round head machine screws (10).

NOTE

It is recommended that a tapered sleeve be installed over the end of the impeller shaft to ease installation of the rotating seal components.

Subassemble the rotating element into the retainer and bellows. Lubricate the I.D. of the bellows with water, and slide this subassembly over the tapered

sleeve and onto the shaft until the polished faces contact. Install the seal spring.

Impeller Installation

(Figure 2)

Inspect the impeller, and replace it if cracked or badly worn.

For maximum pump efficiency, the impeller should be centered within the volute scroll.

To verify the impeller positioning, measure the pump casing and impeller as shown in Figure 6. Use these measurements to calculate the required impeller location (dimension E). Add or remove impeller adjusting shims (17) until dimension E is obtained.

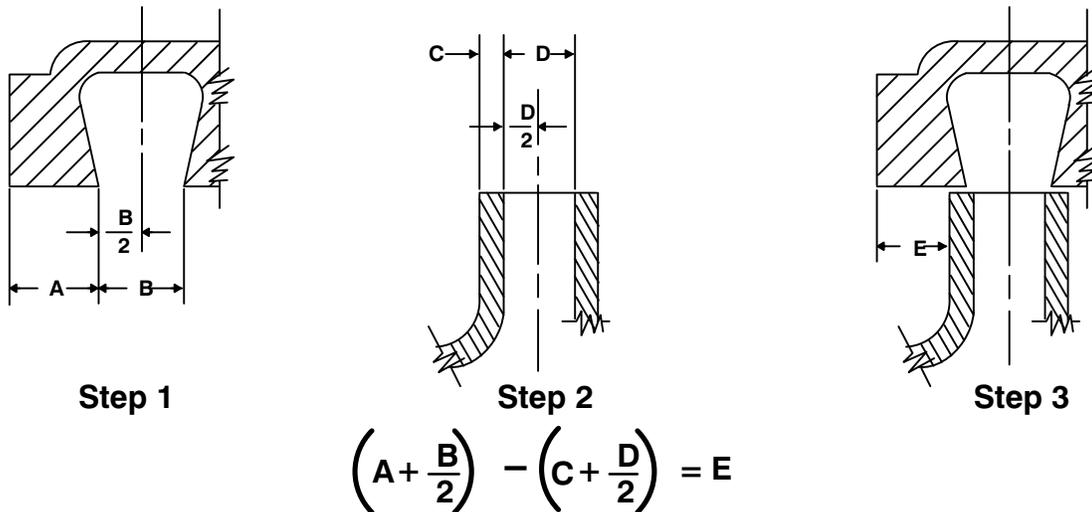

Figure 6. Centering Impeller Within Volute Scroll

Install the correct thickness of impeller shims, and install the impeller key (31) in the shaft keyway. Align the impeller keyway with the key, and slide the impeller onto the shaft until fully seated. Make sure the seal spring seats squarely over the shoulder on the back of the impeller.

NOTE

After the impeller has been properly positioned, check for free rotation. Correct any scraping binding before further reassembly.

When the impeller is properly positioned, secure it with the hardware (41, 42 and 43).

Pump Reassembly

(Figure 2)

If removed at disassembly, press the replacement wear ring (7) into the pump casing until it seats squarely against the shoulder bore.



The wear ring **must** seat squarely in the casing bore or binding and/or excessive wear will result.

Install the casing gasket (30) and secure the casing to the seal plate and intermediate with the nuts (28). See Figure 1, reinstall any leveling shims under the casing mounting feet, and secure the casing to the base (44) with the previously removed hardware (45, 46 and 47).

Final Pump Assembly

Be sure the pump and engine are securely mounted to the base.

Install the suction and discharge lines and open all valves. Make certain that all piping connections are tight, properly supported and secure.

Be sure the pump, intermediate and engine have been properly lubricated, see **LUBRICATION**.

Fill the pump casing with clean liquid. Reinstall the fill plug (47) and tighten it.

Refer to **OPERATION**, Section C, before putting the pump back into service.

LUBRICATION

Seal Assembly

The seal assembly is lubricated by the medium being pumped and no additional lubrication is required.

Bearing

(Figure 2)

The intermediate was fully lubricated when shipped from the factory. Under normal conditions,

add three shots of No. 0 lithium based grease from a grease gun through the grease fitting (12) after each 250 hours of operation or once each month, whichever comes first. **Do not** over-lubricate. Over-lubrication can cause the bearing to over-heat, resulting in premature bearing failure.



If grease is forced out around the shaft as new grease is added, the bearing cavity is full and should be disassembled and cleaned immediately.

There are no provisions in the bearing cavity to drain or flush the lubricant. The pump and intermediate must be disassembled to completely clean and maintain this cavity.

Under normal conditions, change the grease after each 5000 hours of operation, or at 12 month intervals, whichever comes first. Change the grease more frequently if the pump is operated continuously or installed in an environment where variable hot and cold temperatures are common.

When lubricating a dry (overhauled) intermediate, fill the cavity through the lubrication fitting with approximately 2/3 lb. (0.3 kg.) of grease (approximately 1/3 full).

For cold weather operation, consult the factory or a lubricant supplier for the recommended grade of lubricant.

Engine

Consult the literature supplied with the engine, or contact your local Deutz engine representative.

**For U.S. and International Warranty Information,
Please Visit www.grpumps.com/warranty
or call:
U.S.: 419-755-1280
International: +1-419-755-1352**

**For Canadian Warranty Information,
Please Visit www.grcanada.com/warranty
or call:
519-631-2870**