

**INSTALLATION, OPERATION, PARTS LIST,  
AND MAINTENANCE MANUAL**

---

A C



OM-01732-0M01

July 8, 1981



***Motor Driven  
Submersible Pump  
Model S3B1-230V 1P***

**THE GORMAN-RUPP COMPANY • MANSFIELD, OHIO**  
**GORMAN-RUPP OF CANADA LIMITED • ST. THOMAS, ONTARIO, CANADA** Printed in U.S.A.

Copyright by the Gorman-Rupp Company



This Installation, Operation, and Maintenance Manual is designed to help you get the best performance and longest life from your Gorman-Rupp pump.

This pump is designed to operate fully or partially submerged in a sump, wet well, or like configuration. The pump is not designed to pump volatile or flammable fluids. The electric motor is designed for operation through the control box furnished with the pump.

If there are any questions regarding the pump or motor which are not covered in this manual or in other literature accompanying the unit, please contact your Gorman-Rupp distributor, or write:

The Gorman-Rupp Company  
P.O. Box 1217  
Mansfield, Ohio 44901

or

Gorman-Rupp of Canada Limited  
70 Burwell Road  
St. Thomas, Ontario N5P 3R7

The following are used to alert maintenance personnel to procedures which require special attention, to those which could damage equipment, and to those which could be dangerous to personnel:

**NOTE**

Instructions to aid in installation, operation, or maintenance or which clarify a procedure.

**CAUTION**

Instructions which must be followed to avoid causing damage to the product or other equipment incidental to the installation. These describe the procedure required and the damage which could result from failure to follow the procedure.

**WARNING**

Instructions which must be followed to avoid causing injury or death to personnel. These describe the procedure required and the injury which could result from failure to follow the procedure.

**TABLE OF CONTENTS**

WARNINGS	Section A
INSTALLATION	Section B
OPERATION	Section C
TROUBLESHOOTING	Section D
MAINTENANCE AND REPAIR	Section E
WARRANTY	

## WARNINGS

**THESE WARNINGS APPLY TO TYPE S SUBMERSIBLE MOTOR OPERATED PUMPS.**

Before attempting to open or service the pump:

1. Familiarize yourself with this manual.
2. Lock out the power supply to the control panel to ensure that the pump will remain inoperative.
3. Allow the pump to cool if overheated.
4. Close the connecting valve in the discharge line.

Do not attempt to pump volatile or flammable materials, or any liquids for which this pump has not been designed.

After the pump has been installed, make certain that all piping connections are secure before attempting to operate the pump.

The motor of this pump is designed to be operated through the control box furnished with the pump. The control box provides overload protection and power control. Do not connect the pump motor directly to the incoming power lines.

Overheated pumps can cause severe burns or injury. If overheating of the pump casing occurs:

1. Stop the pump immediately.
2. Allow the pump to cool.
3. Refer to instructions in this manual before restarting the pump.



Install, connect, and operate the motor in accordance with the National Electric Code and all local codes. If there is a conflict between the instructions in the manual accompanying the unit and the National Electric Code or the applicable local code, the National or local code shall take precedence. All electrical equipment supplied with this pump conformed to applicable federal regulations and national codes in effect on the date of manufacture.

The electrical power used to operate this pump is high enough to cause injury or death. Make certain that the control box is grounded, and that the power supply is compatible with the motor phase and voltage, before connecting the power source. If the overload unit is tripped during pump operation, correct the problem before restarting the pump.

Obtain the services of a qualified electrician to connect the electrical circuits, and to service the pump motor and control box.

Do not attempt to lift the pump by the motor power cable or the piping. Attach proper lifting equipment to the hoisting bail fitted to the pump.



## INSTALLATION

This section is intended only to summarize recommended installation practices for this pump. If there are any questions concerning a specific installation, contact your Gorman-Rupp distributor or the Gorman-Rupp Company.

Installation of the pump assembly and of the control box are covered separately in this section. Liquid level controls are not furnished with the standard pump, but are available from Gorman-Rupp as optional equipment; for information on installing liquid level controls, see the technical information accompanying the controls.

### PREINSTALLATION INSPECTION

The pump assembly and control box were inspected and tested before being shipped from the factory. Before installation, check for damage which may have occurred during shipment.

Check the pump assembly for cracks, dents, damaged threads, and other obvious damage. Check for and tighten loose bolts, nuts, capscrews, and other attaching hardware. Since gaskets and O-rings tend to shrink after drying, check for and tighten loose hardware securing mating surfaces.

Check the control box for cracks, dents, and other obvious damage. Check that all control box components are securely attached to their mounting surfaces, and that terminals are free of corrosion.

Check to ensure the amps, phase, and voltage indicated on the motor name plate agrees with the same data on the control box.

Carefully read all tags, decals, and markings on the pump assembly and the control box, and perform all duties indicated.

### LUBRICATION

There are two lubrication cavities in this pump. In the motor housing cavity, the motor assembly and rotor shaft bearings are lubricated by uninhibited transformer oil. In the intermediate cavity, the seal assembly is also lubricated by uninhibited transformer oil.

There are two shaft seals in this pump. The lower seal is designed to prevent the liquid being pumped from entering the intermediate cavity at the impeller end. The upper seal prevents oil leakage from the motor housing cavity.

Both lubrication cavities are fully lubricated when the pump is shipped from the factory. Check lubrication levels before installing the pump (see **LUBRICATION** in **MAINTENANCE AND REPAIR**).

**PUMP INSTALLATION**

See figure 1 for pump dimensions.

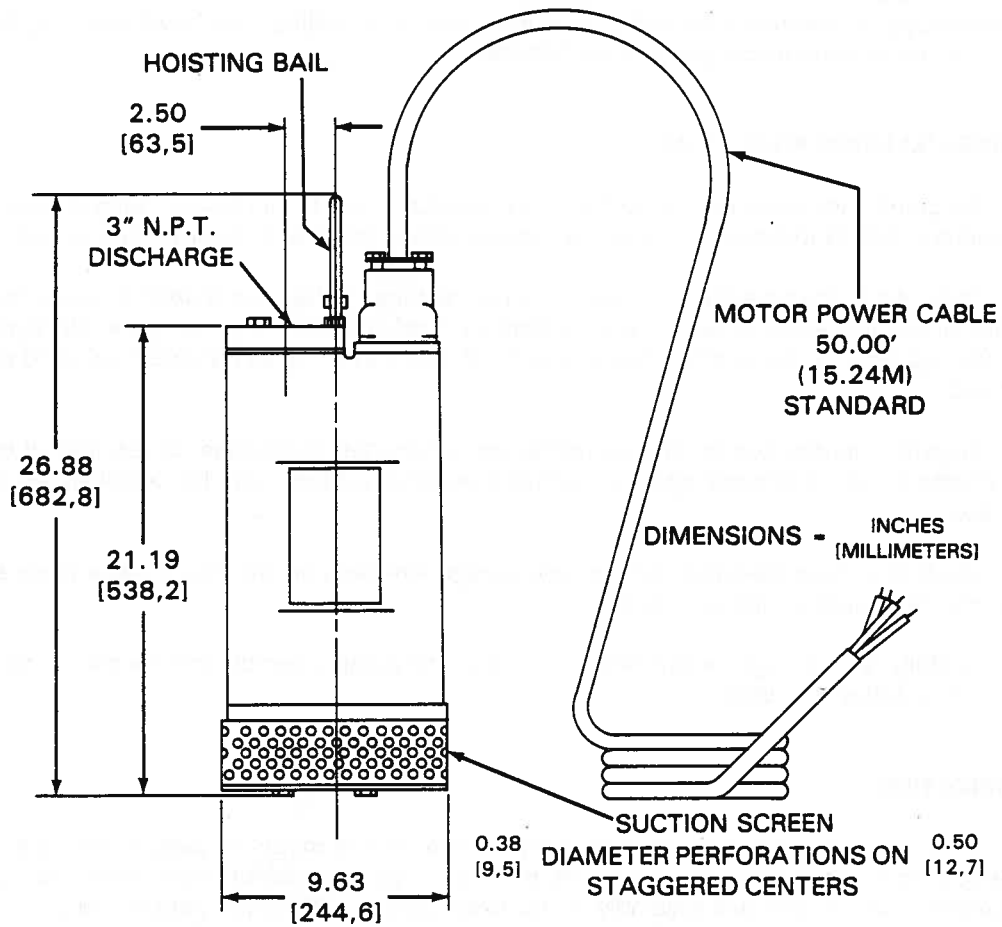

**Figure 1. Pump Dimensions**

Table 1. Pump Specifications

Model Number	Voltage/Phase	Horse-power	Motor Speed (RPM)	Full Load Amperes	No Load Amperes	Locked Rotor Amperes	Discharge Size (NPT)
S3B1	230/1	6	3450	34	8	95	3

**WARNING**

Do not attempt to lift the pump by the motor power cable or the piping. Attach proper lifting equipment to the hoisting bail fitted to the pump. If chains or cables are wrapped around the pump to lift it, make certain that they are positioned so as not to damage pump, and so that the load will be balanced.

This pump is designed to operate fully or partially submerged in a wet well, sump, or similar configuration.

A suction casing surrounding the impeller directs the discharged liquid through passages in the motor housing to the discharge flange on the top of the pump. The liquid absorbs heat from the motor housing as it passes through it, and thus cools the motor. Both models are provided with a threaded flange for 3-inch NPT connection.

**CAUTION**

This pump is not designed to be operated in air for longer than ten minutes. Operation for a longer period can cause the pump to overheat, and the seal and other pump components to deteriorate.

This pump is fitted with a pressure relief valve which will open if vapor pressure within the pump motor reaches a critical point.

The pump will operate if installed on its side, but this method of installation is not recommended because of the tendency of the pump to roll due to motor torque.

The pump should be installed so as to be independently supported. Suspend the pump by the hoisting bail directly in the sump or wet well, or suspend it in a perforated barrel or metal culvert pipe. Where heavy sludge or a debris-covered bottom is encountered, set the pump on supports. See figure 2 for typical pump installations.

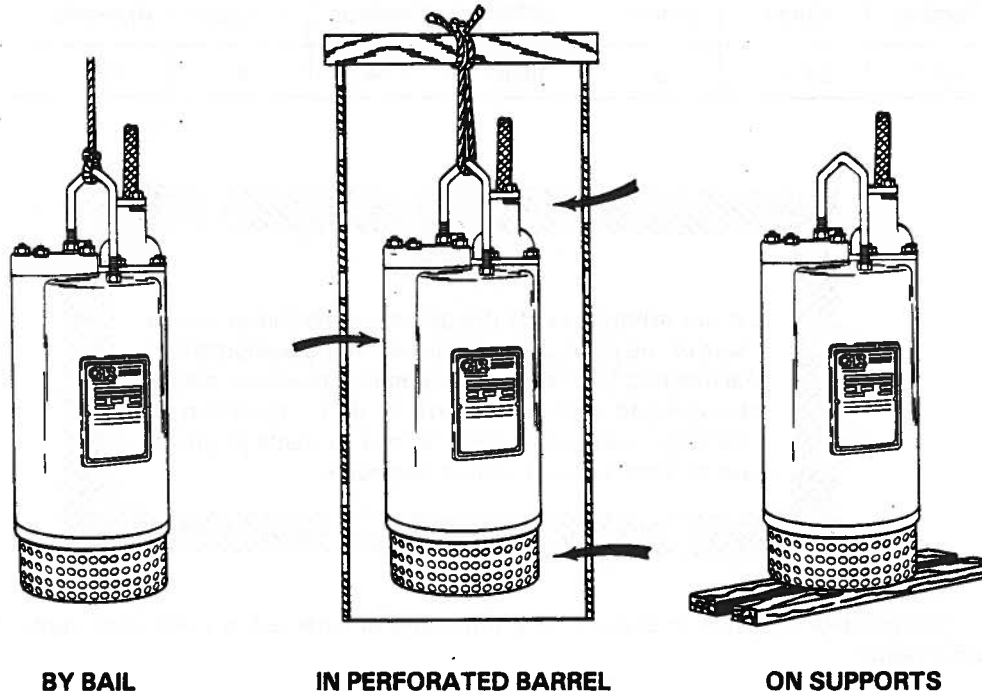

Figure 2. Typical Pump Installations

Suction flow into the pump is through a strainer screen. Any solids which pass through the screen will pass through the pump.

#### PIPING

No suction piping is required.

No discharge piping is furnished with the pump. The discharge piping must be independently supported to avoid strain on the pump which could cause excessive vibration and increased shaft and seal wear.

Make minimum use of elbows and fittings, which substantially increase friction loss, in the discharge piping. If elbows are necessary, use the long-radius type to minimize friction loss.

It is recommended that a check valve and a throttling valve be installed in the discharge line if there is any possibility of a siphoning or back flow action when the pump is shut off.



### CONTROL BOX INSTALLATION

This pump is equipped with a 230 VAC, 60 cycle, single phase, 6 HP motor designed to operate through the control box assembly furnished with the pump.

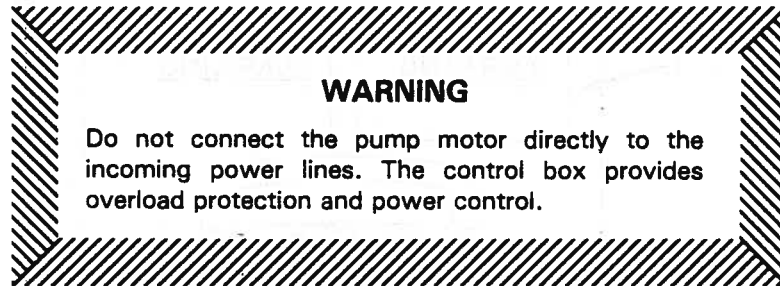

### Enclosure

The control box housing is a NEMA 3R rainproof enclosure with a padlockable front cover. **The enclosure is not watertight, and should not be submerged.** See figure 3 for enclosure dimensions, and callouts of control box assembly external parts.

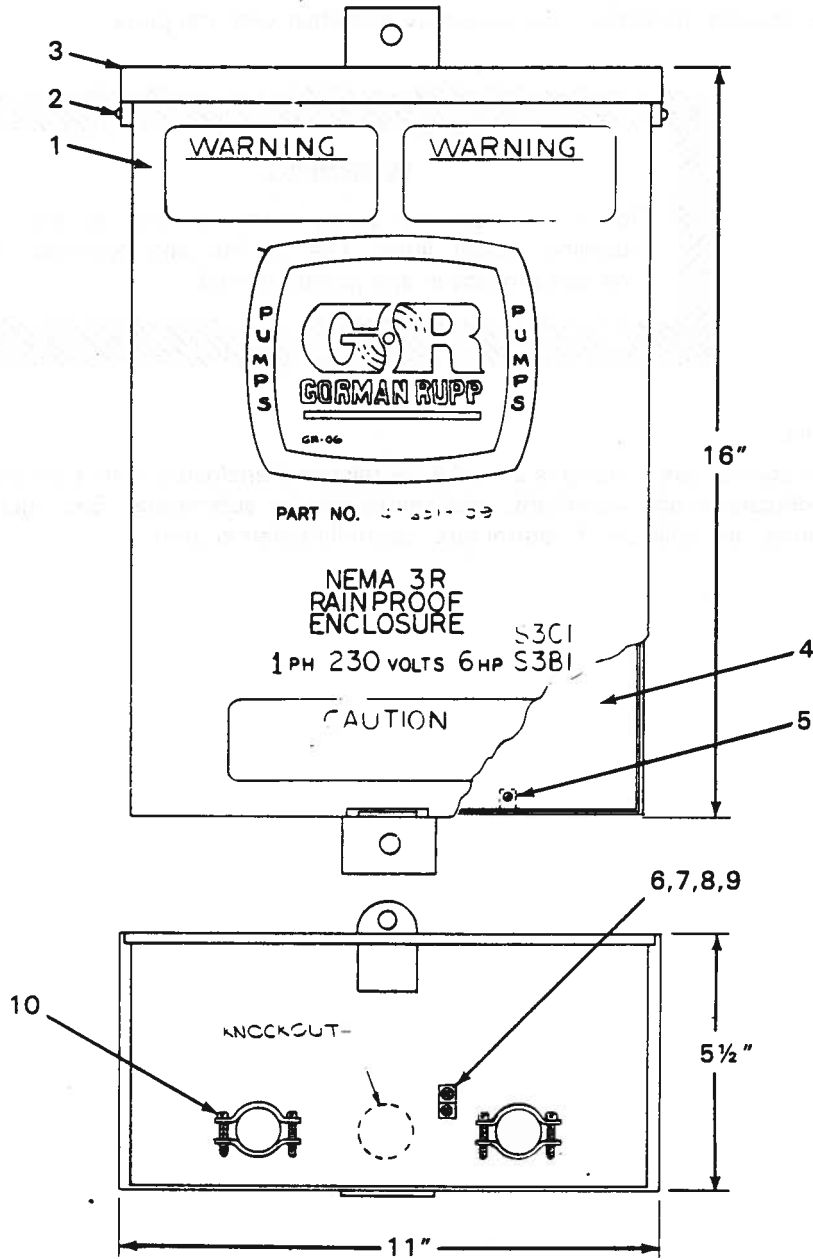

Figure 3. 47631-109 Control Box Assembly

## PARTS LIST, EXTERNAL PARTS

### 47631-109 CONTROL BOX ASSEMBLY

(See figure 7 for internal parts)

ITEM NO.	PART NAME	PART NUMBER	MATERIAL CODE	QTY
1	FRONT COVER	42821-082	—	1
2	TUBULAR RIVET	21118-008	—	2
3	ENCLOSURE	42821-063	—	1
4	INNER PANEL	42821-071	—	1
5	PHILLIPS HEAD MACHINE SCREW	CF#802	15991	2
6	PHILLIPS HEAD MACHINE SCREW	CF#802	15991	2
7	GROUND LUG	27222-002	—	2
8	LOCKWASHER	AK#8	15991	2
9	HEX NUT	D#8	15991	1
10	CABLE CLAMP	27184-164	—	2

To minimize voltage drop, mount the control box enclosure vertically on a flat surface in a location as close as possible to the pump. (Mounting hardware is not furnished with the control box.) If the mounting surface is not perfectly flat, it may be necessary to shim the enclosure. (Shims are not furnished with the control box.)

#### CAUTION

Failure to mount the control box enclosure vertically on a level surface may affect operation of the pump controls.

#### WARNING

The electrical power used to operate this pump is high enough to cause injury or death. Make certain that the control box is properly grounded after installation.

Check to be certain that the control box is securely mounted, and that the front cover latches properly.

**Control Box Connections**

**WARNING**

The electrical power used to operate this pump is high enough to cause injury or death. Obtain the services of a qualified electrician to make all electrical connections.

**WARNING**

Before connecting any cables to the control box, be sure to ground the control box. See figure 4 for suggested grounds.

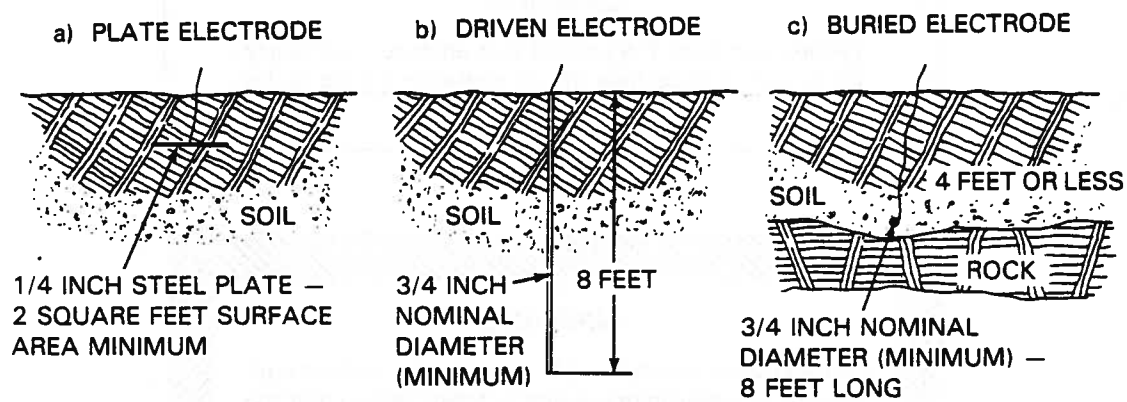

NOTE: ILLUSTRATED GROUNDING METHODS ARE BASED ON RECOMMENDATIONS OF NEC ARTICLE 250. FOLLOW ALL REQUIREMENTS OF NEC AND ALL APPLICABLE LOCAL CODES.

**Figure 4. Suggested Grounding Methods**

a) An iron or steel plate, 1/4 inch thick, completely imbedded in the ground. The plate must present a surface area of at least 2 square feet.

b) A rod or pipe, 3/4 inch diameter minimum, 8 feet long, driven into the ground. Iron or steel pipe must be galvanized or otherwise metal plated to resist corrosion. Do not use a painted pipe or any other pipe coated with material of poor conductivity.

c) Under no circumstances should a ground rod be imbedded less than 4 feet. If rock or stone prevents imbedding more than 4 feet, bury the grounding rod in a horizontal trench.

Space ground rods and plates at least 6 feet from other electrodes and other ground rods, such as those used for signal circuits, radio grounds, lightning rods, etc.

The motor of the pump assembly is shipped from the factory completely wired, and with a 50-foot power cable wired into the terminal housing assembly. If field wiring is required, connect the motor power cable and the field wiring through a junction box; splicing is not recommended.

**WARNING**

The junction box must be completely waterproof, and waterproof integrity must be maintained at all cable entry points, if the junction box is positioned so that it will be submerged at any time.

Because of voltage drop, field wiring should be of adequate size and of proper length. The voltage available at the motor (measured at the control box if mounted within 50 ft. of the pump) must not fall below the minimum voltage listed in Table 2.

1. Use a good quality voltmeter to measure the actual voltage available at the control box. If this voltage is near or below the minimum listed in Table 2, contact the power company and arrange for larger service or request that they supply the rated voltage. Do not proceed with installation until the required minimum voltage (or higher) is available at the control box.

2. The permissible voltage drop from control box to pump is equal to the actual voltage at the control box minus the minimum voltage listed in Table 2. Consult Table 3 and obtain the services of a qualified electrician or electrical contractor to determine wire size and other details of electrical connections required to keep the voltage drop from affecting pump performance.

**Table 2. Pump Motor Voltage Limits**

Nominal Voltage	Phase	Minimum Voltage	Maximum Voltage
230	1	220	245



**Table 3. Cable Requirements for Pump Electrical Connections, Model S3B1**

Voltage/ Phase	Cable Size	Cable OD (inches)	Conductor Dia. (inches)	Amp Rating* at 30°C (amperes)	DC Resist- ance at 25°C (ohms/ 1000 ft)	Voltage Drop at Max. Load per 100 ft
230/1	10	0.75	0.12	25	1.11	7.55

\*Applies only to SO type cable. Refer to manufacturer's specifications for other cable.

The standard pump is not furnished with liquid level controls, but liquid level controls with a 3-position control switch are available from Gorman-Rupp as options.

**WARNING**

Do not connect the incoming power supply to the control box until all electrical connections between the control box and the pump motor, liquid level controls (if installed), and all accessories have been completed. Injury or death may result otherwise.

Before introducing the pump's power cable into the control box, make certain that the incoming power supply has not been connected to the control box, and make certain that the data on the control box matches the data on the pump motor name plate.

**CAUTION**

Use conduit or cable clamps to secure power introduced into the control box, and make certain to maintain the rainproof integrity of the enclosure.

If no liquid level controls are to be installed, connect the pump motor cable to the control box as shown in figures 5 and 7.

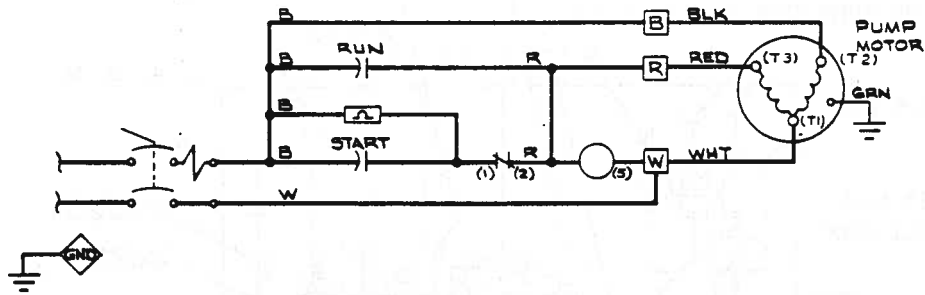

Figure 5. Elementary Wiring Diagram (Without Liquid Level Controls)

If liquid level controls are to be installed, connect the motor power cables and level control power cables as shown in figures 6 and 7.

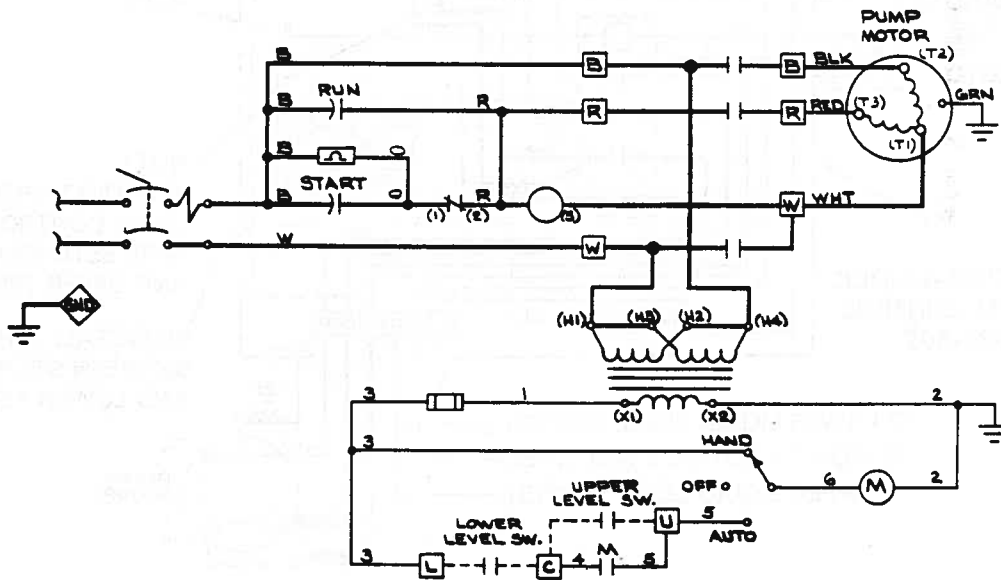
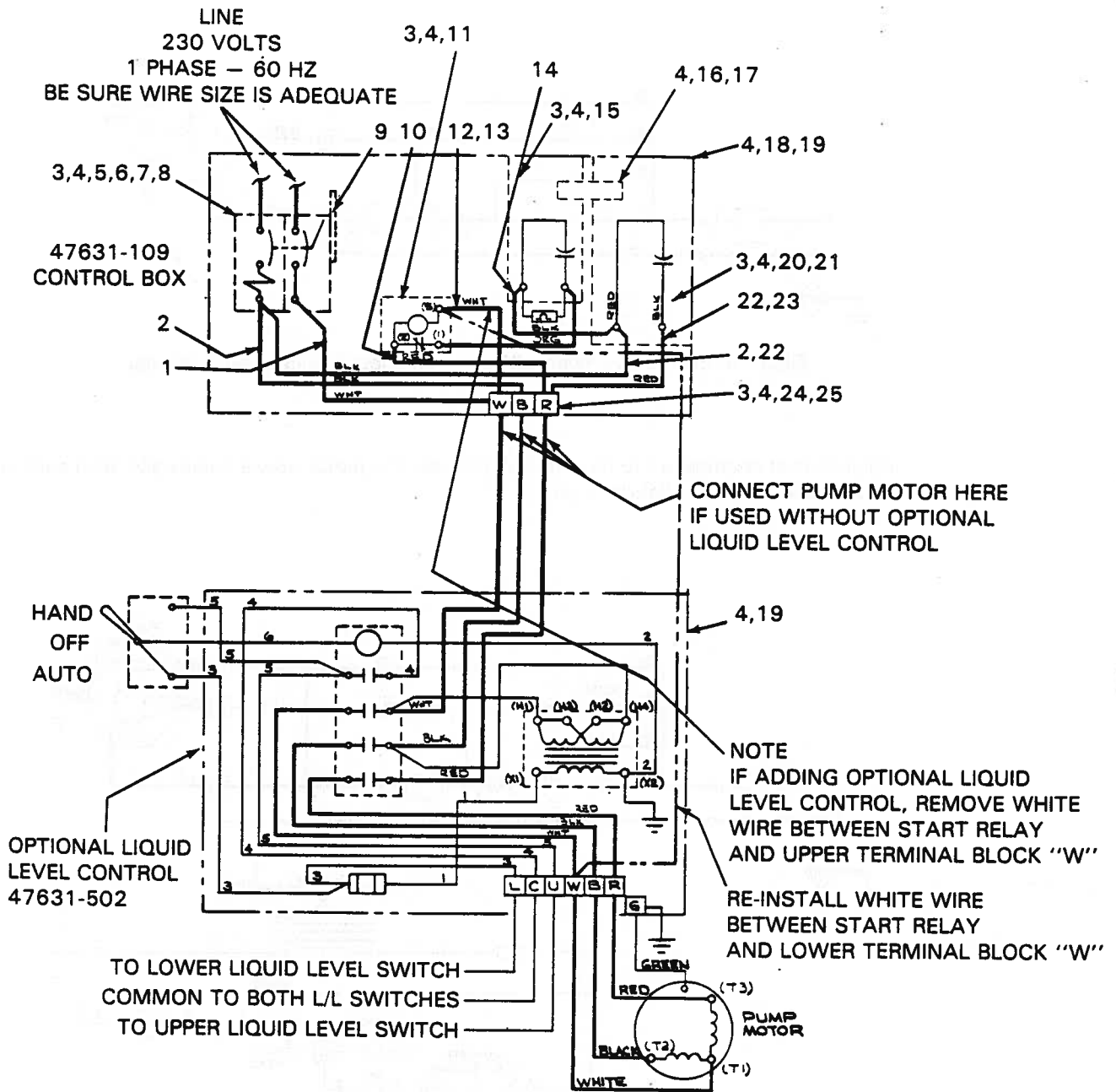

Figure 6. Elementary Wiring Diagram (With Liquid Level Controls)

See figure 7 for a pictorial wiring diagram and callouts of the control box assembly internal parts.



NOTE: WHEN USED WITH ONLY ONE LIQUID LEVEL SWITCH CONNECT TO TERMINALS L AND U. VOLTAGE TO FLOAT SWITCHES - 24 VOLTS TO GROUND.

Figure 7. 47631-109 Control Box Assembly — Pictorial Wiring Diagram



**PARTS LIST, INTERNAL PARTS****47631-109 CONTROL BOX ASSEMBLY**

(See figure 3 for external parts)

ITEM NO.	PART NAME	PART NUMBER	MATERIAL CODE	QTY
1	WIRE ASSEMBLY	18142-131	—	1
2	WIRE ASSEMBLY	18142-133	—	1
3	PHILLIPS HEAD MACHINE SCREW	CF#802	15991	10
4	LOCKWASHER	AK#8	15991	17
5	OVERLOAD UNIT	9485-K	—	1
6	FLAT WASHER	K#8	15991	4
7	SWITCH	12203	—	1
8	TIE HANDLE	10931	10931	1
9	BARRIER	34144-021	—	1
10	WIRE ASSEMBLY	18142-112	—	1
11	START RELAY	9483	—	1
12	WIRE ASSEMBLY	18142-111	—	2
13	FEMALE CONNECTOR, RIGHT ANGLE	27236-043	—	3
14	WIRE ASSEMBLY	18142-113	—	1
15	START CAPACITOR	11343	—	1
16	CAPACITOR CLAMP	34678-002	—	1
17	PHILLIPS HEAD MACHINE SCREW	21543-277	—	1
18	BACK PANEL	34621-063	—	1
19	PHILLIPS HEAD MACHINE SCREW	CF#801	15991	8
20	RUN CAPACITOR	27571-316	—	1
21	BRACKET	33311-010	—	1
22	FEMALE CONNECTOR	S-1768	—	2
23	WIRE ASSEMBLY	18142-132	—	1
24	END BARRIER	27233-026	—	1
25	TERMINAL BLOCK	27233-216	—	3
NOT SHOWN:				
	FEMALE CONNECTOR	S-1790	—	3
	WIRE ASSEMBLY	18142-116	—	1



**WARNING**

Make certain that the incoming power cable is adequately sized, and that the power matches control box and pump motor name plate data. **Be certain to ground the appropriate lead of the incoming power cable before connecting the standard leads of the cable. Failure to do so may result in injury or death.**

**CAUTION**

Use conduit or cable clamps to secure the power cable leads introduced into the control box, and make certain to maintain the rainproof integrity of the enclosure.

With the tie handle set and locked in the OFF position, check all connections to the control box, and make certain that they are secure.

See OPERATION before starting the pump.

## OPERATION

### WARNING

Do not attempt to pump volatile or flammable materials, or any liquids for which this pump has not been designed.

Incoming power to the control box is controlled by the tie handle. When the tie handle is in the OFF position, both the overload unit and the power switch are open, and incoming power to the control box is cut off.

The overload unit will also open automatically and cut off incoming power if the current drawn by the motor exceeds design specifications.

### NOTE

If the overload unit trips, do not reset it immediately. Wait at least ten minutes before resetting the tie handle back to the ON position. If the overload unit continues to trip, an operational problem exists; see **TROUBLESHOOTING**.

To operate the pump, the tie handle must be in the ON position whether the pump is operated with or without liquid level controls.

### LIQUID LEVEL CONTROLS

Three separate liquid level controls are available as options for this pump:

- a) Dewatering; turns the pump on at a predetermined liquid level.
- b) Filling; turns the pump off at a predetermined liquid level.
- c) Float switch, dewatering and filling; turns the pump on and off at predetermined liquid levels.

All controls are designed to be used in conjunction with the 3-way control switch included with that option.



#### **Without Liquid Level Controls**

If no liquid level controls have been installed, pump operation is controlled manually by the tie handle. Set the tie handle at ON to start the pump, and at OFF to stop the pump.

#### **CAUTION**

This pump is not designed to be operated in air for longer than ten minutes. Operation for a longer period can cause the pump to overheat, and the seal and other components to deteriorate. Make certain that there is an adequate supply of liquid in the sump or wet well when operating the pump manually.

#### **With Liquid Level Controls**

If liquid level controls have been installed, set the 3-way selector switch at OFF, and set the tie handle at ON.

If desired to operate the pump under manual control, set the 3-way switch to HAND; the pump will continue to run until the switch is returned to OFF, or reset at AUTO.

If desired to operate the pump under the liquid level controls, set the 3-way switch to AUTO; pump operation will be controlled by the liquid level in the sump or wet well until the switch is returned to OFF, or reset at HAND.

#### **STOPPING**

To cut off all power to the control box and pump motor, set the tie handle in the OFF position.

If liquid level controls have been installed, set the 3-way selector switch to OFF to cut off power to the liquid level controls and the pump motor.

If there is no check valve in the discharge line, prevent siphoning by making certain that the discharge line is not submerged at the point of discharge.

In freezing temperatures, the pump will not freeze as long as the casing is submerged in liquid unless the liquid freezes. If the pump casing is not submerged, or if the liquid begins to freeze, remove the pump from the sump or wet well and allow it to dry thoroughly. Run the pump for two or three minutes to create an air flow to dry the inner walls.

If the pump freezes, submerge it in water for several minutes, then start the pump to check that the shaft rotates. If it does not, resubmerge the pump for an additional ten minutes, or until the shaft rotates.

**WARNING**

Do not attempt to thaw the pump by using a torch or other source of flame; this could heat the oil in the lubrication cavities above the critical point.

**CHECKING PUMP ROTATION**

Check the direction of pump rotation before operation to ensure that the impeller is rotating in the correct direction.

Suspend the pump from the lifting bail. Turn it on momentarily and note the direction of twist or kickback. For correct rotation and operation, the twist must be in the counterclockwise direction.

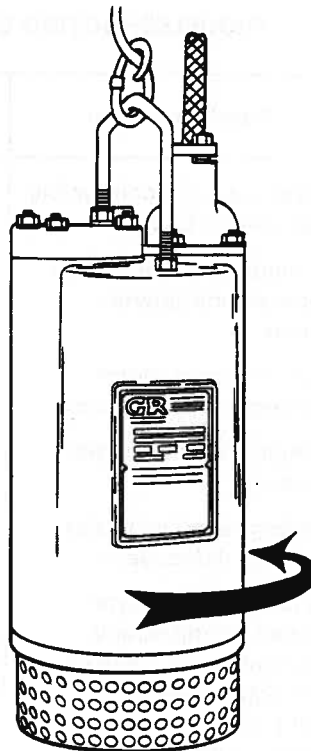



## TROUBLESHOOTING

### WARNING

The electrical power used to operate this pump is high enough to cause injury or death. Do not perform any maintenance or testing unless the power switch/overload unit tie handle is set in the OFF position and locked, or unless the power supply to the control box and motor is otherwise cut off and locked out. Obtain the services of a qualified electrician to troubleshoot and/or service the control box and the pump motor.

When troubleshooting pump operation, set the 3-way pump selector switch (if installed) in the HAND position even though the problem appears to be in the liquid level control system. In this way, operation in each mode can be compared, and problems can be isolated.

Many of the probable remedies listed in the troubleshooting chart below require use of electrical test instruments; for specific procedures, see **Electrical Testing** at the end of the troubleshooting chart.

### TROUBLESHOOTING CHART

Trouble	Possible Cause	Probable Remedy
<p>PUMP FAILS TO START, OVERLOAD UNIT NOT TRIPPED (Manual Mode)</p>	<p>Power source incompatible with control box.</p> <p>No voltage at line side of overload unit power switch.</p> <p>Open circuit in motor windings or power cable.</p> <p>Defective motor power cable.</p> <p>Starting relay, capacitors, or motor defective.</p>	<p>Correct power source.</p> <p>Check power source for blown fuse, open disconnect, broken lead, or loose connection.</p> <p>Check continuity.</p> <p>Replace cord.</p> <p>Check for and replace defective unit.</p>
<p>(Automatic Mode)</p>	<p>(1) Liquid level floats tangled or improperly positioned. (2) Pressure type liquid level controls could be fouled with grease or improperly positioned.</p>	<p>(1) Position liquid level floats at proper level; free float and check that it is free to move. (2) Clean and/or position liquid level controls.</p>

Continued—Page 2

Trouble	Possible Cause	Probable Remedy
Continued	<p>Control circuit wiring connections to control box incorrect or loose.</p> <p>Defective liquid level control or switch.</p>	<p>Correct/tighten connections.</p> <p>Replace defective unit.</p>
OVERLOAD UNIT TRIPS	<p>Low or high voltage, or excessive voltage drop between pump and control box.</p> <p>Defective start or run capacitors; defective start relay.</p> <p>Defective insulation in motor windings or power cable; defective windings.</p> <p>Impeller jammed due to debris or insufficient clearance.</p> <p>Bearing(s) frozen.</p> <p>Terminal housing incorrectly wired.</p>	<p>Measure voltage at control box. Check that wiring is correct type, size, and length.</p> <p>Check capacitors and relay.</p> <p>Check insulation resistance; check continuity.</p> <p>Disassemble pump and check impeller.</p> <p>Remove motor housing and check bearing(s).</p> <p>Check terminal housing internal connections. Wire leads should be connected as follows: T1 common to white, T2 run to black, T3 start to red.</p>
MOTOR RUNS, BUT PUMP FAILS TO DELIVER RATED DISCHARGE	<p>Discharge head too high.</p> <p>Low or incorrect voltage.</p> <p>Discharge throttling valve partially closed; check valve installed improperly.</p> <p>Discharge line clogged or restricted; hose kinked.</p> <p>Liquid in sump or wet well too thick.</p> <p>Strainer screen or impeller clogged.</p> <p>Insufficient liquid level in sump or wet well.</p>	<p>Reduce discharge head, or install staging adapter and additional pump.</p> <p>Measure control box voltage. While pump is running and while shut off.</p> <p>Open discharge valve fully; check piping installation.</p> <p>Check discharge lines; unkink hose.</p> <p>Dilute liquid.</p> <p>Clear clog(s). Stop pump; back flow may flush away debris.</p> <p>Stop pump until liquid level rises.</p>

Continued—Page 3



Trouble	Possible Cause	Probable Remedy
Continued	Worn impeller vanes; excessive impeller clearance.	Check impeller and clearance.
PUMP RUNS WITH EXCESSIVE NOISE OR VIBRATION	<p>Pumping entrained air.</p> <p>Damaged or unbalanced impeller.</p> <p>Discharge piping not properly supported.</p> <p>Impeller jammed or loose.</p> <p>Motor shaft or bearings defective.</p> <p>Pump cavitating.</p>	<p>Check liquid level in sump or wet well; check position of pump; check position of liquid level float or switches.</p> <p>Replace impeller.</p> <p>Check piping installation.</p> <p>Check impeller.</p> <p>Remove motor housing and check motor and bearings.</p> <p>Reduce discharge head or restrict flow on low head applications.</p>
PUMP DOES NOT START AND STOP AT DESIRED HIGH AND LOW LIQUID LEVELS (Automatic Mode)	<p>Liquid level floats or switches improperly connected to control box.</p> <p>Liquid level float or switches improperly installed in sump or wet well.</p> <p>Liquid level float tangled.</p> <p>Liquid level switches or control float faulty.</p>	<p>Check wiring diagrams.</p> <p>Check installation.</p> <p>Check installation.</p> <p>Check for defective units.</p>



**ELECTRICAL TESTING**

It is recommended that a Megohmer — manufactured by the Herman H. Sticht Co. of New York City — or an instrument of comparable range and quality be used in the following tests.

**WARNING**

The electrical power used to operate this pump is high enough to cause injury or death. Do not perform any testing unless the power switch/overload unit tie handle is set in the OFF position and locked, or unless the power supply to the control box and motor is otherwise cut off and locked out. Obtain the services of a qualified electrician to test the electrical components of this pump.

**CAUTION**

Be certain to refer to the wiring diagrams in the **INSTALLATION** section of this manual before reconnecting any electrical components which have been disconnected.

**Motor and Motor Power Cable Continuity**

To check continuity, zero-balance the ohmmeter set at the RX1 scale, and test as follows:

a) Disconnect the motor power cable leads from the control box (or junction box), and connect the test leads to any two of the three standard power cable leads (not to the green ground lead). If there is a high resistance reading on the ohmmeter, there is an open or broken circuit caused by a break in the power cable or motor windings, or by a bad connection between the motor and the power cable. Switch one test lead to the third standard motor cable lead, and test again.

b) If an open or broken circuit is indicated, check the power cable for obvious damage, and replace as necessary (see **MAINTENANCE AND REPAIR**). If there is no apparent damage to the motor cable, remove the terminal housing (see **MAINTENANCE AND REPAIR**) and check the connection between the motor leads and the motor terminals.



c) If an open or broken circuit condition exists after all connections have been checked and tightened, disconnect the motor leads from the motor terminals, and test each power cable lead for continuity. If any breaks are discovered in the power cable, replace the entire cable; splicing or other methods of repair are not recommended.

d) If no break is found in the power cable, check the motor leads for continuity. If the test reading indicates an open or broken circuit, there is an open circuit in the motor.

### NOTE

It is recommended that a defective motor be returned to your Gorman-Rupp distributor or to the Gorman-Rupp factory for repair.

### Insulation Resistance

To check insulation, zero-balance the ohmmeter set at the RX100K scale, and test as follows:

a) Disconnect the motor power cable leads from the control box (or junction box). Connect one test lead to the power cable green ground lead, and touch the other test lead to each of the three standard leads in turn.

b) The reading obtained will indicate resistance values in both the power cable and the motor windings. If the resistance reading is infinity ( $\infty$ ), the insulation is in good condition. If the reading is between infinity ( $\infty$ ) and 1 megohm, the insulation is acceptable but should be rechecked periodically. If the reading is less than 1 megohm, the insulation should be checked more closely; a reading of zero indicates that the power cable or the motor is grounded.

c) To determine whether the power cable or the motor is grounded, remove the terminal housing (see **MAINTENANCE AND REPAIR**), disconnect the motor leads from the motor terminals, and test the power cable leads and motor leads separately.

### Capacitors

The start capacitor is designed to split the electrical phase during the initial power surge at motor startup. The start capacitor is controlled by the start relay at motor startup. When the motor reaches load speed, the start relay cuts out and permits the run capacitor to maintain operation. Both the start and run capacitors are located in the control box.

### CAUTION

Before disconnecting the capacitor leads, discharge the capacitors; use a screwdriver with an insulated handle, and place the blade across the two terminals of each capacitor to short the terminals.

Zero-balance the ohmmeter set to read RX100K, and test the capacitors as follows:

- a) Disconnect the capacitor leads, and remove the resistor from the start capacitor.
- b) Place a test lead against each of the terminals of the start capacitor for a few seconds. If the ohmmeter needle moves toward zero then slowly drifts back to the left, the capacitor is good. If the needle remains at infinity ( $\infty$ ) the capacitor is open; if the needle remains at zero, the capacitor is shorted. In either case, the capacitor must be replaced.
- c) Test the run capacitor as in b). In addition, test the metal run capacitor for shorts to ground by touching one test lead to the capacitor case and the other lead to each of the capacitor terminals in turn. The ohmmeter should read infinity ( $\infty$ ); if it does not, the capacitor is grounded and must be replaced.

#### **Start Relay**

The start relay is located in the control box.

Disconnect the two wires from relay terminal 2. Zero-balance the ohmmeter set to read RX100K, and touch one lead to relay terminal 2 and the other to relay terminal 5. The resistance reading should be between 4000 and 6000 ohms; if the reading is not in this range, the start relay is defective and should be replaced.

#### **NOTE**

With the exception of the motor assembly, repair of individual electrical components is not recommended. Replace defective and/or malfunctioning components.

Main body of faint text, appearing to be several paragraphs of a document or report.

Second section of faint text, possibly a continuation of the main body or a separate paragraph.

Third section of faint text, located in the lower middle part of the page.



# MAINTENANCE AND REPAIR

MAINTENANCE AND REPAIR OF THE WEARING PARTS OF THE PUMP WILL MAINTAIN PEAK OPERATING PERFORMANCE.

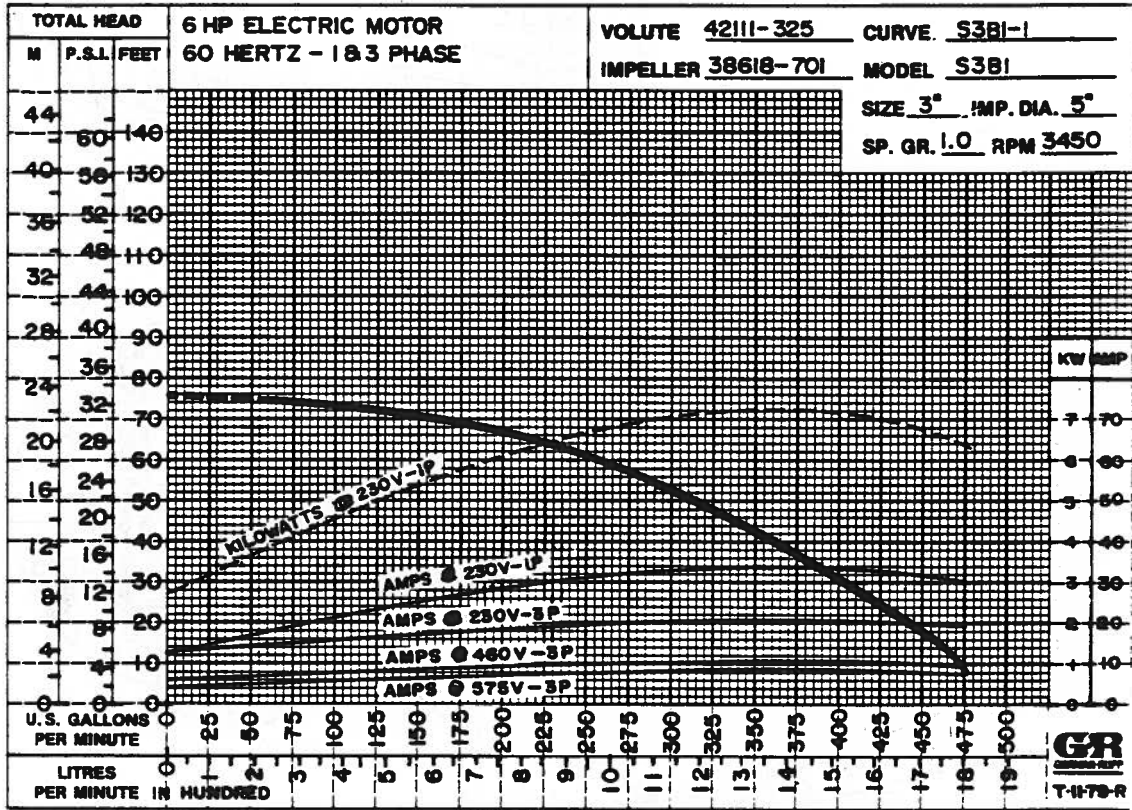

\* STANDARD PERFORMANCE FOR PUMP MODEL S3B1-230V 1P

\* Based on 70°F clear water at sea level with minimum suction lift. Since pump installations are seldom identical, your performance may be different due to such factors as viscosity, specific gravity, elevation, temperature, and impeller trim.

If your pump serial number is followed by an "N" or if you have a question on performance, contact The Gorman-Rupp Company.

# SECTIONAL DRAWING

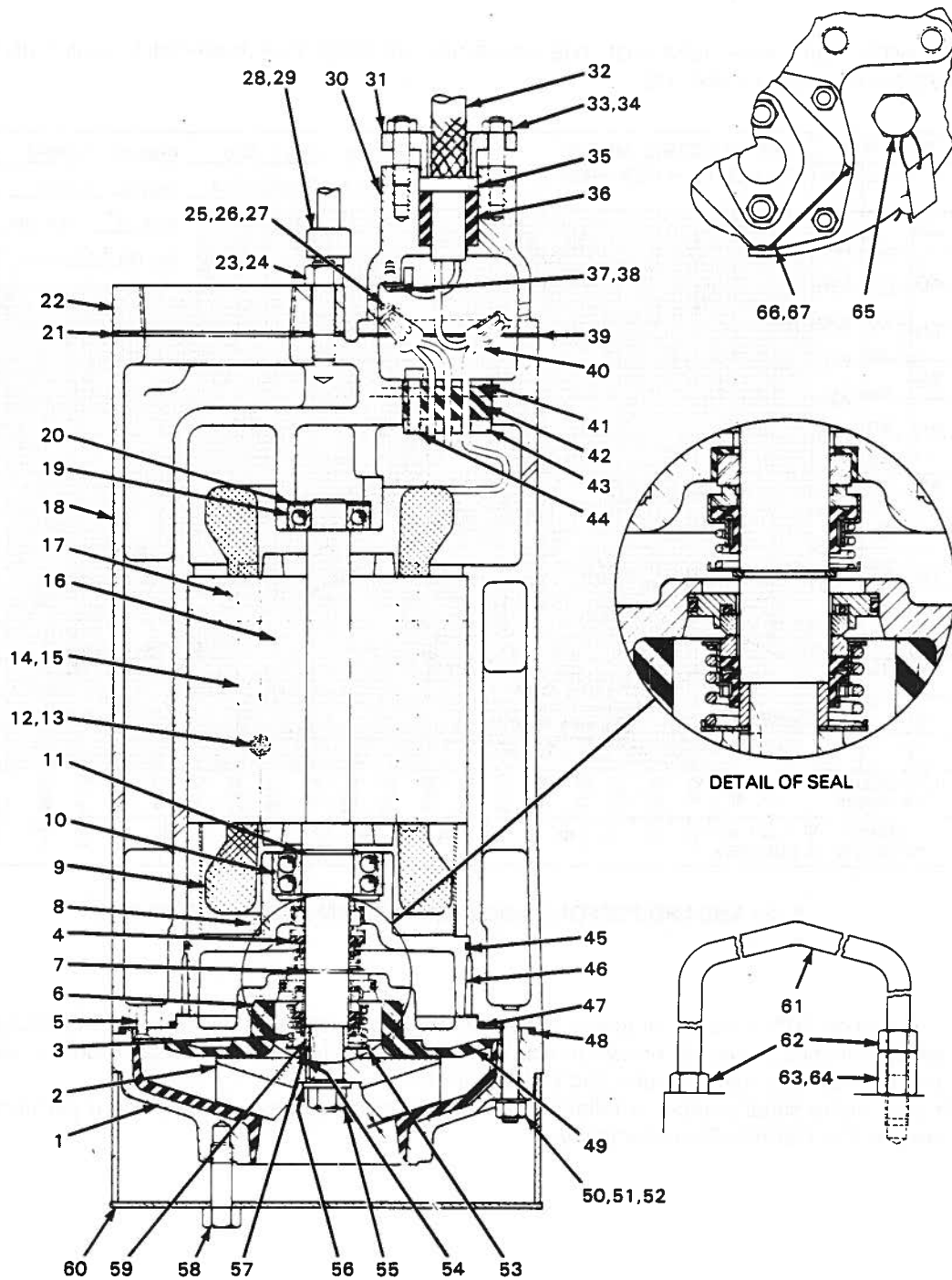

Figure 1. Pump Model S3B1-230V 1P

**PARTS LIST****PUMP MODEL S3B1-230V 1P**

(From S/N up)

Above Serial Numbers Do Not Apply To Pumps Made In Canada.

ITEM NO.	PART NAME	PART NUMBER	MATL CODE	QTY	ITEM NO.	PART NAME	PART NUMBER	MATL CODE	QTY
1	SUCTION HEAD - BONDED	42111-325	-	1	44	SOCKET HD CAPSCREW	13879	15990	4
2	★IMPELLER	38618-701	-	1	45	★INTERMEDIATE O-RING	25152-258	-	1
3	★PUMP END SEAL ASSY	25277-345	-	1	46	INTERMEDIATE	38311-803	-	1
4	★MOTOR END SEAL	S-1832	-	1	47	★MOTOR HOUSING O-RING	S-2194	-	1
5	FLAT HD MACHINE SCREW	Y#10-03	17000	2	48	★SUCTION HEAD O-RING	25152-270	-	1
6	SEAL CAV DRN/FILL PLUG	PC-04	17000	1	49	BONDED SEAL PLATE	42111-064	-	1
7	★SEAL RETAINING RING	S-0362	-	1	50	STUD	C-0610	17000	6
8	MTR CAV DRN/FILL PLUG	PC-04	17000	1	51	LOCKWASHER	J-06	17000	6
9	★MOTOR BUSHING	31173-017	-	1	52	HEX NUT	D-06	17000	6
10	★LOWER BALL BEARING	S-1834	-	1	53	SEAL SPRING RETAINER	8793	17990	1
11	★ROTOR SNAP RING	S-1831	-	1	54	★IMPELLER KEY	N-0302½	17000	1
12	ALLEN HEAD SETSCREW	GA-0603	15990	1	55	NYLON LOCKNUT	BC-08-S	17000	1
13	SOCKET PIPE PLUG	PC-04	17000	1	56	FLAT WASHER	KB-08	17000	1
14	NAME PLATE	2813-CY	17020	1	57	★IMPELLER SHIM SET	2-Y	17090	1
15	DRIVE SCREW	BM#04-03	17000	6	58	NYLOCK CAPSCREW	BT-0806	15991	3
16	★ROTOR	47112-805	-	1	59	★PUMP END SEAL SLEEVE	13878	17020	1
17	STATOR	47113-810	-	1	60	★STRAINER	46611-001	-	1
18	MOTOR HOUSING	38311-013	-	1	61	HOISTING BAIL	31928-009	-	1
19	★UPPER BALL BEARING	S-1044	-	1	62	HEX NUT	D-08	15991	2
20	★SPRING WASHER	S-1554	-	1	63	STUD	C-0806	15991	1
21	★DISCHARGE FLNG GSKT	38687-045	-	1	64	COUPLING NUT	31811-019	-	1
22	DISCHARGE FLANGE	38641-006	-	1	65	RELIEF VALVE ASSEMBLY	46431-608	-	1
23	STUD	C-0809	15991	3	66	INFORMATION PLATE	38816-047	-	1
24	HEX NUT	D-08	15991	3	67	DRIVE SCREW	BM#04-03	17000	4
25	STUD	C-0505	15991	4	NOT SHOWN:				
26	HEX NUT	D-05	15991	4		CONTROL BOX ASSY	47631-109	-	1
27	LOCKWASHER	J-05	15991	4		PUMP OIL - QUART	9568	-	1
28	HEAVY PIPE NIPPLE	THA-0608	15071	1		CABLE TIE	27111-212	-	1
29	FILL PIPE CAP	V-06	11991	1		IMPELLER PULLER ASSY	10285	-	1
30	TERMINAL HOUSING	10757	13040	1	OPTIONAL:				
31	TERMINAL CAP	10756-B	13040	1		STAGING DISCH FLANGE	38641-006	-	1
32	CABLE ASSEMBLY	9166-F	-	1		DISCHARGE FLNG GSKT	38687-045	-	1
33	STUD	C-0806	15991	2		GASKET SET (REPAIRS)	11000-S	-	1
34	HEX NUT	D-06	15991	2		LIQUID LEVEL CONTROL (DEWATERING)	GRP48-3	-	1
35	CABLE GRIP	11227-B	-	1		LIQUID LEVEL CONTROL (FILLING)	GRP48-6	-	1
36	BUSHING	10758-F	19100	1		FLOAT SWITCH (DEWATERING/FILLING)	27471-155	-	1
37	RD HD MACHINE SCREW	X#10-01½	14990	1		FLOAT SWITCH 24 VOLT	47631-502	-	1
38	T-TYPE LOCKWASHER	AK#10	15991	1		SS IMPELLER	38618-701	12070	1
39	★TERMINAL PLATE GASKET	10321-G	20000	1		SS STRAINER ASSY	46611-006	24170	1
40	CONNECTOR	S-1718	-	3					
41	UPPER TERMINAL PLATE	13880	23010	1					
42	★MOTOR LEAD BUSHING	13884-A	19140	1					
43	LOWER TERMINAL PLATE	13881	23010	1					

★ INDICATES PARTS RECOMMENDED FOR STOCK

## PUMP AND MOTOR DISASSEMBLY AND REASSEMBLY

All instructions for disassembly and reassembly are keyed to the sectional view (see figure 1) and the accompanying parts list.

### WARNING

The electrical power used to operate this pump is high enough to cause injury or death. Make certain that the tie handle on the control box inner panel is in the OFF position and locked, or that the power supply to the control box has been otherwise cut off and locked out, before attempting to open or service the pump assembly.

Cut off the power supply to the control box, and close the connecting valve in the discharge line. If discharge hose is used with this pump, it is not necessary to disconnect the hose before removing the pump from the sump or wet well; if rigid discharge piping is used, disconnect the piping or the discharge flange (22) before attempting to remove the pump.

To remove the discharge flange, remove the hex nuts (24) securing the flange to the motor housing (18).

Remove the pump assembly from the sump or wet well.

### WARNING

Do not attempt to lift the pump by the motor power cable or the discharge hose or piping. Attach proper lifting equipment to the carry handle. If chains or cables are wrapped around the pump to lift it, make certain that they are positioned so as not to damage the pump, and so that the load will be balanced.



**PUMP END DISASSEMBLY****Screen and Impeller Disassembly**

When the pump is supported in an inverted position, the strainer assembly (60), impeller (2), and the pump end seal assembly (3) may be serviced without draining the oil from the seal cavity. If the motor end seal assembly (4) is to be serviced, the seal cavity should be drained.

To drain the oil, let the pump cool, lay it on its side, and remove the seal cavity drain/fill plug (6) located at the lower end of the motor housing.

**CAUTION**

Let the pump cool before removing the seal cavity drain/fill plug. Pressure built up within a hot pump could cause the oil to spray out when the plug is removed. Remove plug slowly and permit pressure to vent to atmosphere.

**NOTE**

If the oil drained from the seal cavity is cloudy or contains foreign liquid, it may be an indication that the seal is leaking at the impeller end.

Support the pump in an inverted position during disassembly of the pump and seal.

To remove the strainer screen, remove the nylock capscrews (58) securing the strainer screen to the motor housing.

For access to the impeller, remove the hex nuts (52) and lockwashers (51), securing the bonded suction head (1) to the motor housing.

Place a block of wood between the vanes of the impeller to prevent shaft rotation, and remove the impeller nylon locknut (55) and flat washer (56). Using the impeller puller assembly furnished with the pump, slide the impeller off the shaft; retain the impeller key (54).

Remove the impeller shims (57); for ease of reassembly, tag and tie the shims.

**Seal Disassembly**

Work the elements of the pump end seal assembly (3) off the shaft. If necessary, use a stiff wire with a hooked end to remove the stationary element in the bonded seal plate (49).

For access to the motor end seal assembly (4), remove the flat head screws (5) securing the seal plate to the motor housing, and remove the seal plate. Remove the seal retaining ring (7), and work the motor end seal assembly elements off the shaft.

Unless cracked or otherwise worn, it is not necessary to remove the intermediate. If replacement is required, slide the intermediate out of the motor housing.

Disassembly of the motor is rarely required except for a replacement of the motor rotor, stator, or bearings. Do not disassemble the motor unless it is necessary and a clean, well-equipped shop is available.

**NOTE**

If the motor housing components are to be serviced, see **MOTOR DISASSEMBLY** in this section. Do not reassemble the pump end components at this time.

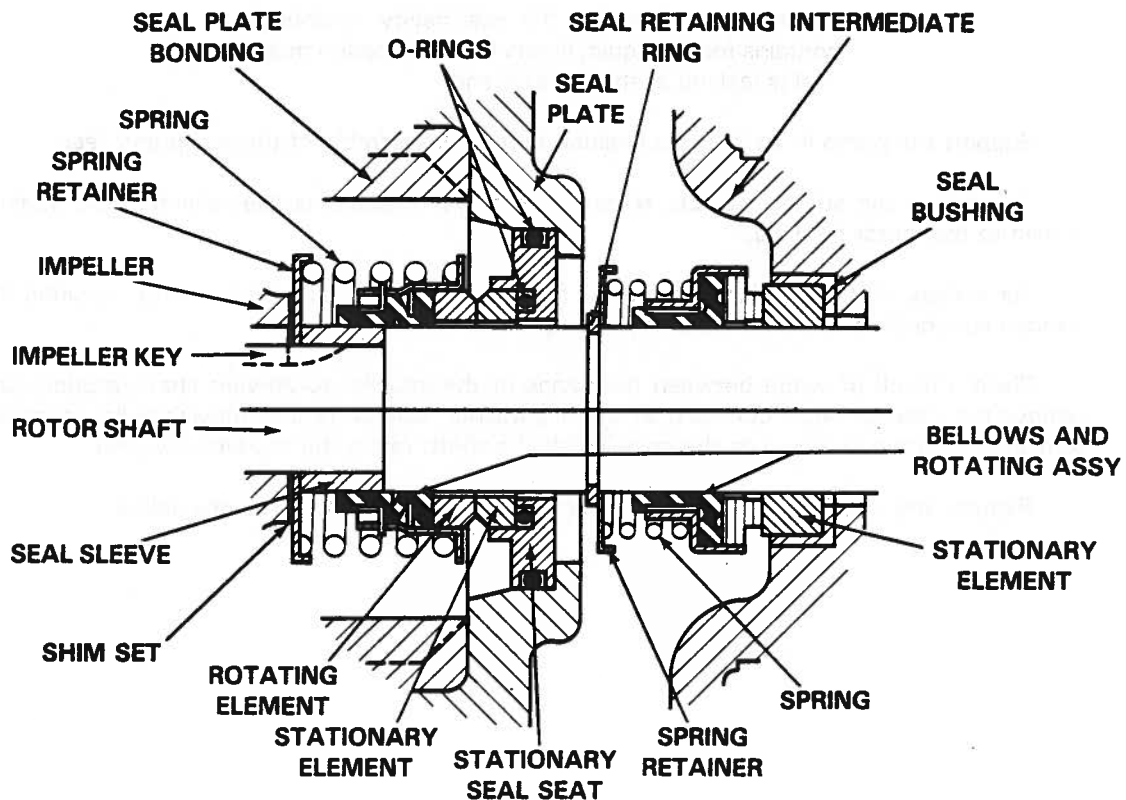
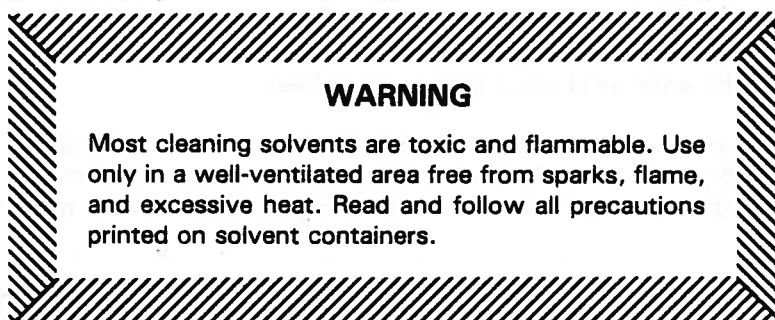

Figure 2. Seal Assemblies 25277-345 and S-1832

## PUMP END REASSEMBLY

### Seals Reassembly

Clean the rotor shaft, the intermediate and the bonded seal plate, and their bores, with a soft cloth soaked in cleaning solvent.



If the intermediate has been removed, replace the intermediate O-ring (45), and position the intermediate within the motor housing.

The motor end seal assembly is not normally reused because of the precision finish of its lapped faces, but if it is necessary to reuse the old seal, wash all metallic parts in cleaning solvent and dry thoroughly.

Inspect the seal components for wear, scoring, grooves, and other damage that might cause leakage. If any seal components are worn replace the entire seal; never mix old and new seal parts.

Place a drop of light lubricating oil between the precision finished faces of each set of seal elements, and lubricate the bellows assembly with petroleum jelly or oil.

Install the seal assembly as a complete unit, making certain that the stationary element seats in the bore of the intermediate (see figure 2).

For the correct order of installation of seal components, see figure 2.

Install the seal retaining ring (7), and replace the motor housing O-ring (47). Position the bonded seal plate on the shaft, and secure with the flat head machine screws.

The pump end seal assembly is not normally reused because of the precision finish of its lapped faces, but if it is necessary to reuse the old seal, wash all metallic parts in cleaning solvent and dry thoroughly.

Inspect the seal components for wear, scoring, grooves, and other damage that might cause leakage. The O-rings must be replaced, but if any other seal components are worn replace the entire seal; never mix old and new seal parts.



### **Impeller and Screen Reassembly**

Reinstall the impeller adjusting shims.

Inspect the impeller, and replace it if cracked or worn. Install the impeller key and the impeller. Install the impeller flat washer, and coat the threads of the rotor shaft with Never-Seez or equivalent compound. Place a block of wood between the vanes of the impeller to block shaft rotation, install the impeller nylon locknut, and torque the locknut to 60 ft. lbs. (720 inch lbs.).

Turn the impeller to check that it rotates freely; if the impeller rubs against the bonded seal plate, add impeller shims until the impeller rotates freely.

Replace the suction head O-ring (48). Install the suction head. Coat the threads of the motor housing studs (50) with Never-Seez or equivalent compound, and install the lockwashers and hex nuts securing the suction head to the motor housing; torque the hex nuts to 20 ft. lbs. (240 inch lbs.).

A clearance of .008 to .015 inch between the impeller and the bonded suction head is recommended for maximum pump efficiency. Measure this clearance, and add or remove impeller shims until it falls between the recommended limits. Turn the shaft to check that the impeller rotates freely.

Position the strainer screen on the suction head, and install the long nylock capscrews through the strainer screen and the suction head. Make certain that the strainer screen seats properly against the shoulder of the suction head.

**MOTOR DISASSEMBLY****Terminal Housing and Power Cable Disassembly****NOTE**

Make sure the pump assembly is standing upright to prevent loss of oil from the motor housing when the terminal housing is removed.

The terminal housing (30) and the power cable assembly (32) can be disassembled without disassembling the motor housing.

To remove the terminal housing, remove the hex nuts (26) and lockwashers (27) securing the terminal housing to the motor housing, and raise the assembly for access to the connectors (40) securing the power cable leads to the motor leads. The connectors are wrapped with underwater tape; cut and unwrap the tape, then remove the connectors, and separate the pump power cable leads from the motor leads.

If the power cable is to be replaced, remove the round head machine screw (37) and lockwasher (38) securing the ground wire to the terminal housing, remove the hex nuts (33) securing the terminal cap (31) to the terminal housing and slide the terminal cap back along the cable. Remove the cable grip (35) and pull the power cable from the terminal housing.

**Motor Housing and Components Disassembly**

Drain the oil from the motor housing cavity before removing the motor components. To drain the oil, let the pump cool, lay it on its side, and remove the motor cavity drain/fill plug (8).

**CAUTION**

Let the pump cool before removing the motor cavity drain/fill plug. Pressure built up within a hot pump could cause the oil to spray out when the plug is removed. Remove plug slowly and permit pressure to vent to atmosphere.

**NOTE**

If the oil drained from the motor housing cavity is cloudy or contains foreign liquid, it may be an indication that the shaft seal is leaking at the motor end.



Remove the socket head capscrews (44), the upper and lower terminal plates (41 and 43), and the motor lead bushing (42). Pull the motor leads from the terminal plates and bushing.

See **Pump End Disassembly**, and remove all pump end components.

With the pump end disassembled and the intermediate removed, remove the motor bushing (9). Remove the rotor (16) and the upper and lower ball bearings (19 and 10) as an assembly, retaining the wavy spring washer (20).

It is recommended that the stator (17) be left in place unless it is defective. To remove the stator, remove the socket pipe plug (13) in the motor housing, and loosen the allen head setscrew (12) underneath the pipe plug.

**CAUTION**

Do not attempt to rewind the stator. Winding tolerances are closely controlled by the manufacturer, and any deviation can cause damage or operating problems. Replace the stator, or return it to your Gorman-Rupp distributor or the Gorman-Rupp factory, if defective.

**Hoisting Bail and Relief Valve**

If the hoisting bail (61) requires replacement, remove the hex nuts (62) securing the bail to the motor housing.

It is recommended that the pressure relief valve assembly (65) be replaced at each overhaul. Use Loctite pipe sealant with Teflon, or equivalent sealant, on the threads of the assembly when installing it.

**MOTOR REASSEMBLY****Motor Housing and Components Reassembly**

Clean the stator, rotor shaft, and shaft bearings with a soft cloth soaked in cleaning solvent. Make certain that the cloth and solvent are free of dirt and metal chips which could interfere with bearing operation.

Rotate the rotor shaft bearings to check for roughness, and check that the bearing balls are not discolored; replace the bearings as necessary.

If the stator has been removed, slip a sleeve over the stator lead wires to prevent damage to them, and install the stator in the motor housing.

Install the upper ball bearing on the rotor shaft, making certain that it seats against the shaft shoulder. Install the wavy spring washer (20) in the motor housing bore, and install the rotor snap ring (11) on the rotor shaft.

Install the lower ball bearing on the rotor shaft, making certain that it seats against the rotor snap ring, and slip the assembled rotor and bearings through the stator and into the bearing housing bore.

Install the motor bushing, making certain that the two drain holes are located next to the intermediate, and aligned with the drain plug.

Replace the intermediate O-ring (9) and install the intermediate, making certain that the lower ball bearing seats in the intermediate bore.

Tighten the allen head setscrew securing the stator in place. Coat the threads of the pipe plug covering the setscrew with Never-Seez or equivalent compound, install and torque to 20 ft. lbs. (240 inch lbs.).

See **PUMP END REASSEMBLY**, and reassemble the pump end components.

See **LUBRICATION**, for lubrication of seal and bearing cavities.

### **Terminal Housing and Power Cable Reassembly**

Lubricate the motor leads and the bores in the terminal plates and the motor lead bushing. Feed the motor leads through the lower plate and push them through the motor lead bushing. When the leads are about 1 ½ to 2 inches above the top of the bushing, install the upper terminal plate.

Start two socket head capscrews through the upper plate and bushing and into the lower plate. Do not tighten the screws. Lubricate the outside of the bushing and the bore in the motor housing, and push the assembled plates and bushing into the housing until they are in the proper position.

Install the two remaining socket head capscrews. Verify that there is enough of the motor leads protruding to permit connection to the pump power cable. Tighten the four capscrews evenly and alternately to 4 ft. lbs. (48 inch lbs.).

Clean the exterior of the power cable with warm water and mild detergent, and check for obvious physical damage. Check the cable for continuity and insulation resistance (see Electrical Testing in TROUBLESHOOTING). Do not attempt repairs except at either end of the cable; splicing is not recommended.

If the ends of the pump power cable leads are frayed or broken, cut them off beyond the damaged area and strip back the insulation about a ½ inch.

Lubricate the outside of the power cable and the bore of the cable grip for ease of assembly. Slip the cable grip over the power cable, and insert the cable through the bushing and into the terminal housing. Verify that there is sufficient cable lead length to permit wire connections, and position the terminal cap on the terminal housing studs (33) and secure with the hex nuts (34).

Connect the ground lead to the terminal housing and secure with the round head machine screw and t-type lockwasher (38). Make sure the lead makes good contact with the terminal housing.

Replace the terminal housing gasket (39).

Connect the motor leads and the power cable leads according to color. Use the underwater tape (Gorman-Rupp Part Number 18666-068) on all connectors. Run the tape between the leads, then double back. Finish the assembly by stretching the tape and wrapping around the connectors and leads.

Apply Never-Seez, or equivalent compound, to the studs (25) of the motor housing and position the terminal housing on the motor housing. Install the lockwashers (27) and hex nuts (26) securing the terminal housing to the motor housing. Torque the hex nuts to 11 ft. lbs. (132 inch lbs.).



**LUBRICATION**

Use of the correct lubricant is critical to the efficient operation of this pump. Use of uninhibited transformer oil in the grade specified in Table 2 is recommended.

**Table 2. Pump Oil Specifications**

<b>Specifications</b>	
Type . . . . .	Uninhibited transformer oil
Neutralization . . . . .	0.01
Dielectric . . . . .	26,000 (min)
Pour point . . . . .	-55°F
<b>Typical products and suppliers</b>	
Gulf Oil Company . . . . .	Transcrest H
Texas Oil Company . . . . .	Texaco 55
Sun Oil Company . . . . .	Sunoco D Transformer Oil
Westinghouse Electric Company . . . . .	WEMCO C-2772
General Electric Company . . . . .	Transil 10C

**Motor End Seal Cavity**

Lay the pump on its side, remove the seal cavity drain/fill plug (8) in the motor housing, and add approximately 1 pint of a recommended grade of uninhibited transformer oil. Apply Loctite pipe sealant with Teflon #92, or equivalent sealant, to the threads of the drain/fill plug, and reinstall and tighten the plug.

**Motor Housing Cavity**

Stand the pump upright, remove the fill pipe cap (29) on top of the motor housing, and add approximately 3 quarts of uninhibited transformer oil. Apply Loctite pipe sealant with Teflon #92, or equivalent sealant, to the threads of the heavy pipe nipple (28), and reinstall and tighten the fill pipe cap.

**FINAL ASSEMBLY**

If the discharge flange has been separated from the motor housing, replace the discharge flange gasket (21). Coat the threads of the studs (23) with Never-Seez, or equivalent compound, and install the hex nuts (24), securing the discharge flange to the motor housing.

Connect the discharge hose, and position the pump in the sump or wet well. If rigid discharge piping is used, connect the piping after the pump has been positioned.

Open the connecting valve in the discharge line, and make certain that the liquid level in the sump or wet well is adequate for pump operation, before starting the pump.

## WARRANTY

Pumping units manufactured by The Gorman-Rupp Company, Mansfield, Ohio are guaranteed to be free from defects in material and workmanship for one year from date of shipment from factory in Mansfield, Ohio. The obligation under this Warranty, statutory or otherwise, is limited to replacement or repair at Mansfield, Ohio factory or at a point designated by Gorman-Rupp, of such part as shall appear to us, upon inspection at such point, to have been defective in material or workmanship.

This Warranty does not obligate The Gorman-Rupp Company to bear the cost of labor or transportation charges in connection with replacement or repair of defective parts; nor shall it apply to a pump upon which repairs or alterations have been made unless authorized by Gorman-Rupp.

No warranty is made in respect to engines, motors, or trade accessories, such being subject to warranties of their respective manufacturers.

In Submersible Pumps, pump and motor are integral and Submersibles are warranted as a unit. Since motor is subject to an important degree upon quality and performance of electrical controls, unit warranty is valid only when controls have been specified and provided by Gorman-Rupp.

No express implied or statutory warranty, other than herein set forth is made or authorized to be made by Gorman-Rupp.

In no event shall The Gorman-Rupp Company be liable for consequential damages or contingent liabilities arising out of the failure of any Gorman-Rupp pump or parts thereof to operate properly.

THE GORMAN-RUPP COMPANY  
Mansfield, Ohio

NOTE: In Canada, all above references to "The Gorman-Rupp Company, Mansfield, Ohio" is understood to mean "Gorman-Rupp of Canada Limited, St. Thomas, Ontario."

**THE GORMAN-RUPP COMPANY • MANSFIELD, OHIO**

**GORMAN-RUPP OF CANADA LIMITED • ST. THOMAS, ONTARIO, CANADA** Printed in U.S.A.

Copyright by the Gorman-Rupp Company