

**INSTALLATION, OPERATION,
AND MAINTENANCE MANUAL**
WITH PARTS LIST



PA SERIES PUMP

MODEL
PA6C60C-F6L

THE GORMAN-RUPP COMPANY • MANSFIELD, OHIO

GORMAN-RUPP OF CANADA LIMITED • ST. THOMAS, ONTARIO, CANADA Printed in U.S.A

www.grpumps.com

©2011 The Gorman-Rupp Company

Register your new
Gorman-Rupp pump online at
www.grpumps.com

Valid serial number and e-mail address required.



The engine exhaust from this product contains chemicals known to the State of California to cause cancer, birth defects or other reproductive harm.

RECORD YOUR PUMP MODEL AND SERIAL NUMBER

Please record your pump model and serial number in the spaces provided below. Your Gorman-Rupp distributor needs this information when you require parts or service.

Pump Model: _____

Serial Number: _____

TABLE OF CONTENTS

INTRODUCTION	PAGE I – 1
SAFETY - SECTION A	PAGE A – 1
INSTALLATION – SECTION B	PAGE B – 1
Pump Dimensions	PAGE B – 1
PREINSTALLATION INSPECTION	PAGE B – 2
Battery Installation	PAGE B – 2
POSITIONING PUMP	PAGE B – 2
Lifting	PAGE B – 2
Mounting	PAGE B – 3
SUCTION AND DISCHARGE PIPING	PAGE B – 3
Materials	PAGE B – 3
Line Configuration	PAGE B – 3
Connections to Pump	PAGE B – 3
Gauges	PAGE B – 3
SUCTION LINES	PAGE B – 3
Fittings	PAGE B – 3
Strainers	PAGE B – 4
Sealing	PAGE B – 4
Suction Lines In Sumps	PAGE B – 4
Suction Line Positioning	PAGE B – 4
DISCHARGE LINES	PAGE B – 5
Siphoning	PAGE B – 5
Valves	PAGE B – 5
ALIGNMENT	PAGE B – 5
AUTO-START	PAGE B – 5
Float Switch Installation	PAGE B – 6
OPERATION – SECTION C	PAGE C – 1
OPERATION	PAGE C – 1
PRIMING	PAGE C – 1
STARTING	PAGE C – 1
Manual Starting	PAGE C – 1
Automatic Starting	PAGE C – 2
Priming	PAGE C – 2
ROUTINE OPERATION	PAGE C – 3
OPERATION IN EXTREME HEAT	PAGE C – 3
OPERATIONAL CHECKS	PAGE C – 3
Leakage	PAGE C – 3
Pump Vacuum Check	PAGE C – 3
Liquid Temperature And Overheating	PAGE C – 3
Strainer Check	PAGE C – 4
STOPPING	PAGE C – 4
Manual Stopping	PAGE C – 4
Automatic Stopping	PAGE C – 4
Safety Shutdown System	PAGE C – 4

TABLE OF CONTENTS
(continued)

PERIODIC CHECKS	PAGE C – 5
Seal Cavity and Bearing Lubrication	PAGE C – 5
Bearing Temperature Check	PAGE C – 5
Engine Fuel Filter	PAGE C – 5
Engine Oil	PAGE C – 5
Air Compressor	PAGE C – 5
Air Compressor Drive Belt	PAGE C – 5
COLD WEATHER PRESERVATION	PAGE C – 5
TROUBLESHOOTING – SECTION D	PAGE D – 1
PREVENTIVE MAINTENANCE	PAGE D – 3
PUMP MAINTENANCE AND REPAIR - SECTION E	PAGE E – 1
STANDARD PERFORMANCE CURVE	PAGE E – 1
PARTS LISTS:	
Pump Model	PAGE E – 3
Power Unit Kit	PAGE E – 5
Pump Assembly	PAGE E – 7
Pump End Assembly	PAGE E – 9
Repair Rotating Assembly	PAGE E – 11
Priming Chamber Kit	PAGE E – 12
Priming Chamber Assembly	PAGE E – 13
Drive Assembly	PAGE E – 14
PUMP AND SEAL DISASSEMBLY AND REASSEMBLY	PAGE E – 15
Priming Chamber Removal And Disassembly	PAGE C – 16
Discharge Check Valve Removal and Disassembly	PAGE C – 16
Back Cover Plate and Wear Plate Removal	PAGE C – 16
Separating Pump And Drive Assembly From Engine	PAGE C – 16
Draining Oil From Seal Cavity	PAGE C – 17
Loosening Impeller	PAGE C – 17
Pump Casing Removal	PAGE C – 18
Impeller Removal	PAGE C – 18
Seal Removal	PAGE C – 18
Shaft and Bearing Removal and Disassembly	PAGE C – 19
Shaft and Bearing Reassembly and Installation	PAGE C – 19
Securing Bearing Housing And Drive Assembly To Engine	PAGE C – 21
Seal Reassembly and Installation	PAGE C – 22
Impeller Installation And Adjustment	PAGE C – 24
Pump Casing Installation	PAGE C – 24
Wear Plate and Back Cover Installation And Adjustment	PAGE C – 24
Discharge Check Valve Reassembly And Installation	PAGE C – 25
Priming Chamber Assembly And Installation	PAGE C – 25
LUBRICATION	PAGE C – 26
Seal Assembly	PAGE C – 26
Bearings	PAGE C – 26
Engine	PAGE C – 26

INTRODUCTION

Thank You for purchasing a Gorman-Rupp pump. **Read this manual** carefully to learn how to safely install and operate your pump. Failure to do so could result in personal injury or damage to the pump.

This pump is a PA Series, priming-assisted centrifugal model. The unit is designed for handling non-volatile, non-flammable liquids containing specified entrained solids. The basic material of construction is ductile iron with stainless steel shaft and ductile iron wearing parts.

Because pump installations are seldom identical, this manual cannot possibly provide detailed instructions and precautions for every aspect of each specific application. Therefore, it is the responsibility of the owner/installer of the pump to ensure that applications not addressed in this manual are performed **only** after establishing that neither operator safety nor pump integrity are compromised by the installation. Pumps and related equipment **must** be installed and operated according to all national, local and industry standards.

If there are any questions regarding the pump which are not covered in this manual or in other literature accompanying the unit, please contact your Gorman-Rupp distributor or the Gorman-Rupp Company:

The Gorman-Rupp Company
P.O. Box 1217
Mansfield, Ohio 44901-1217
Phone: (419) 755-1011
 or:
Gorman-Rupp of Canada Limited
70 Burwell Road
St. Thomas, Ontario N5P 3R7
Phone: (519) 631-2870

For information or technical assistance on the engine, contact the engine manufacturer's local dealer or representative.

The following are used to alert personnel to procedures which require special attention, to those which could damage equipment, and to those which could be dangerous to personnel:



Immediate hazards which WILL result in severe personal injury or death. These instructions describe the procedure required and the injury which will result from failure to follow the procedure.



Hazards or unsafe practices which COULD result in severe personal injury or death. These instructions describe the procedure required and the injury which could result from failure to follow the procedure.



Hazards or unsafe practices which COULD result in minor personal injury or product or property damage. These instructions describe the requirements and the possible damage which could result from failure to follow the procedure.

NOTE

Instructions to aid in installation, operation, and maintenance or which clarify a procedure.

SAFETY - SECTION A

This information applies to Prime Aire® Series pumps. Refer to the manual accompanying the engine or power source before attempting to begin operation.

Because pump installations are seldom identical, this manual cannot possibly provide detailed instructions and precautions for each specific application. Therefore, it is the owner/installer's responsibility to ensure that applications not addressed in this manual are performed only after establishing that neither operator safety nor pump integrity are compromised by the installation.



Before attempting to open or service the pump:

1. Familiarize yourself with this manual.
2. Shut down the engine and disconnect the positive battery cable to ensure that the pump will remain inoperative.
3. Allow the pump to completely cool if overheated.
4. Check the temperature and make sure the pump is cool before opening any covers, plates, or plugs.
5. Close the suction and discharge valves.
6. Vent the pump slowly and cautiously.
7. Drain the pump.



This pump is equipped with an automatic starting system, and is subject to automatic restart. Keep hands and clothing away from the unit to prevent injury during automatic operation. Disconnect the positive battery cable before per-

forming any maintenance. Failure to do so may result in serious personal injury.



Do not attempt to disengage any part of an overheated pump unit. Vapor pressure within the pump casing can eject these parts with great force when they are disengaged. Allow the pump to completely cool before servicing it.



This pump is designed to handle most non-volatile, non-flammable liquids containing specified entrained solids. Do not attempt to pump volatile, corrosive, or flammable liquids which may damage the pump or endanger personnel as a result of pump failure.



Use lifting and moving equipment in good repair and with adequate capacity to prevent injuries to personnel or damage to equipment. Attach lifting equipment to the lifting device fitted to the pump. If chains or cable are wrapped around the pump to lift it, make certain that they are positioned so as not to damage the pump, and so that the load will be balanced. The bail is intended for use in lifting the pump assembly only. Suction and discharge hoses and piping must be removed from the pump before lifting.



After the pump has been installed, make certain that the pump and all piping or hose connections are tight, properly supported and secure before operation.



Do not operate the pump against a closed discharge valve. If operated against a closed discharge valve, pump components will deteriorate, and the liquid could come to a boil, build pressure, and cause the pump casing to rupture or explode. Momentary closure of a discharge valve is acceptable only when required for startup or shutdown procedures.



Do not remove plates, covers, gauges, pipe plugs, or fittings from an overheated pump. Vapor pressure within the pump can cause parts being disengaged to be ejected with great force. Allow the pump to cool completely before servicing.



This pump may be used to handle materials which could cause illness through direct exposure or emitted fumes. Wear adequate protective clothing when working on the pump or piping.



Do not operate the pump without guards in place over the rotating parts. Exposed rotating parts can catch clothing, fingers or tools, causing severe injury to personnel.

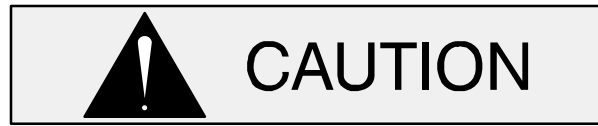

Pumps and related equipment must be installed and operated according to all national, local and industry standards.

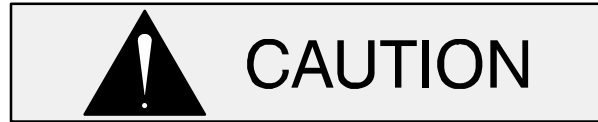

Make sure the pump is level. Lower jack stands and chock the wheels, if so equipped. Use caution when positioning the skid-mounted unit to prevent damage to the fuel tank.



Do not operate an internal combustion engine in an explosive atmosphere. When operating an internal combustion engine in an enclosed area, make sure exhaust fumes are piped to the outside. These fumes contain carbon monoxide, a deadly gas that is colorless, tasteless and odorless.



Fuel used by internal combustion engines presents an extreme explosion and fire hazard. Make certain that all fuel lines are securely connected and free of leaks. Never refuel a hot or running engine. Avoid overfilling the fuel tank. Always use the correct type of fuel.



Never tamper with the governor to gain more power. The governor establishes safe operating limits that should not be exceeded. The maximum continuous operating speed for this pump is 1900 RPM.

INSTALLATION – SECTION B

Review all SAFETY information in Section A.

Since pump installations are seldom identical, this section offers only general recommendations and practices required to inspect, position, and arrange the pump and piping.

Most of the information pertains to a standard **static lift** application where the pump is positioned above the free level of liquid to be pumped.

If installed in a **flooded suction application** where the liquid is supplied to the pump under pressure, some of the information such as mounting, line

configuration, and priming must be tailored to the specific application. Since the pressure supplied to the pump is critical to performance and safety, **be sure** to limit the incoming pressure to 50% of the maximum permissible operating pressure as shown on the pump performance curve.

For further assistance, contact your Gorman-Rupp distributor or the Gorman-Rupp Company.

Pump Dimensions

See Figure 1 for the approximate physical dimensions of this pump.

OUTLINE DRAWING

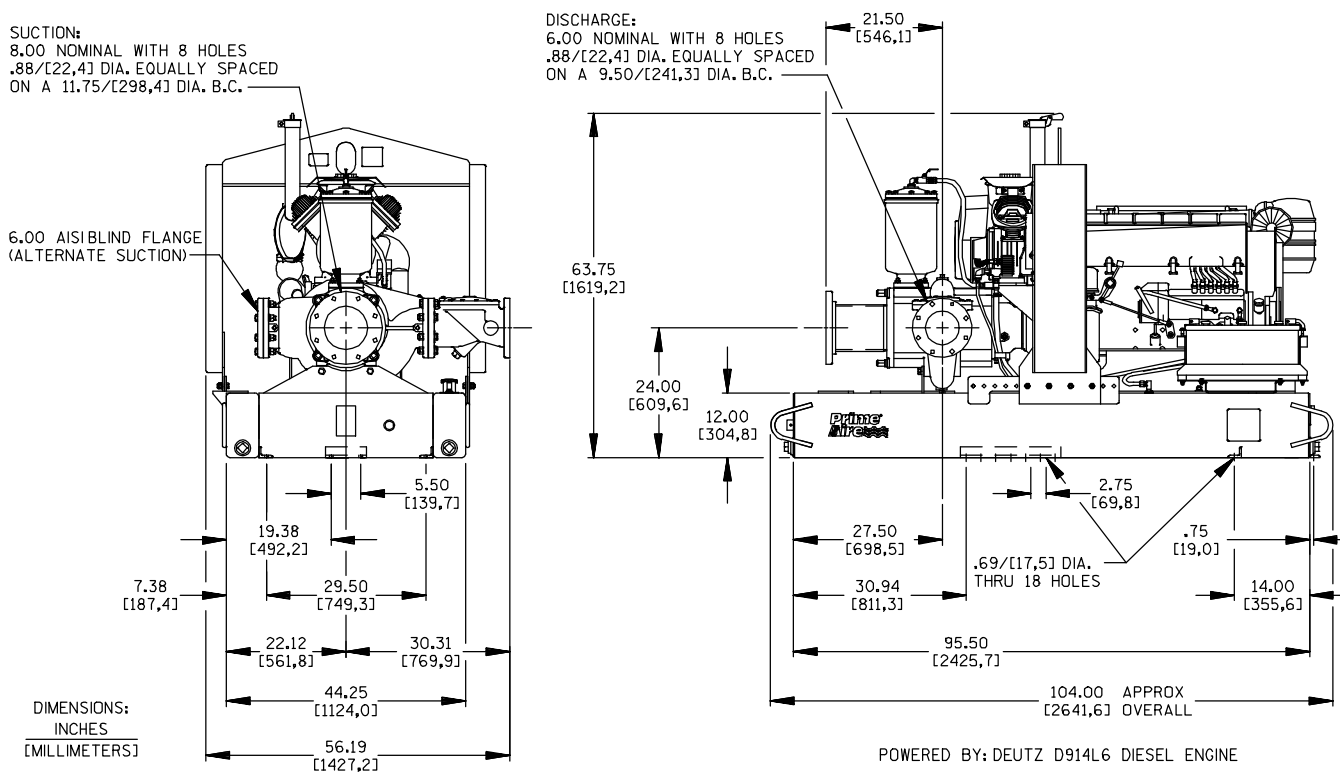

Figure 1. Pump Model PA6C60C-F6L

PREINSTALLATION INSPECTION

The pump assembly was inspected and tested before shipment from the factory. Before installation, inspect the pump for damage which may have occurred during shipment. Check as follows:

- a. Inspect the pump for cracks, dents, damaged threads, and other obvious damage.
- b. Check for and tighten loose attaching hardware. Since gaskets tend to shrink after drying, check for loose hardware at mating surfaces.
- c. Carefully read all tags, decals, and markings on the pump assembly, and perform all duties indicated. Note that the pump shaft rotates in the required direction.



Only operate this pump in the direction indicated by the arrow on the pump body and on the accompanying decal. Otherwise, the impeller could become loosened from the shaft and seriously damage the pump.

- d. Check levels and lubricate as necessary. Refer to **LUBRICATION** in the **Maintenance and Repair Manual** and perform duties as instructed.
- e. If the pump has been stored for more than 12 months, some of the components or lubricants may have exceeded their maximum shelf life. These **must be inspected or replaced** to ensure maximum pump service.

If the maximum shelf life has been exceeded, or if anything appears to be abnormal, contact your Gorman-Rupp distributor or the factory to determine the repair or updating policy. **Do not** put the pump into service until appropriate action has been taken.

Battery Installation

Unless otherwise specified on the pump order, the engine battery is **not** included with engine driven units.

Refer to the information accompanying the battery and/or electrolyte solution for activation and charging instructions.

Before installing the battery, clean the positive and negative cable connectors, and the battery terminals. Secure the battery by tightening the holddown brackets. The terminals and clamps may be coated with petroleum jelly to retard corrosion. Connect and tighten the positive cable first, then the negative cable.

POSITIONING PUMP



Use lifting and moving equipment in good repair and with adequate capacity to prevent injuries to personnel or damage to equipment. Attach lifting equipment to the lifting device fitted to the pump. If chains or cable are wrapped around the pump to lift it, make certain that they are positioned so as not to damage the pump, and so that the load will be balanced. The bail is intended for use in lifting the pump assembly only. Suction and discharge hoses and piping must be removed from the pump before lifting.

Lifting

Pump unit weights will vary depending on the mounting and drive provided. Check the shipping tag on the unit packaging for the actual weight, and use lifting equipment with appropriate capacity. Drain the pump and remove all customer-installed equipment such as suction and discharge hoses or piping before attempting to lift existing, installed units.



The pump assembly can be seriously damaged if the chains or cables used to lift and move the unit are improperly wrapped around the pump.

Mounting

Locate the pump in an accessible place as close as practical to the liquid being pumped. Level mounting is essential for proper operation. The pump may have to be supported or shimmed to provide for level operation and eliminate vibration.

For engine driven units, the pump **must** be positioned as level as possible to ensure sufficient lubrication and fuel supply to the engine.

If the pump has been mounted on a moveable base, make certain the base is stationary by setting the brake and blocking the wheels before attempting to operate the pump.



If the pump has been mounted on a moveable base, do not attempt to operate the pump unless the unit is level. Be sure the leveling stands are positioned on a solid surface, and the wheels are chocked.

SUCTION AND DISCHARGE PIPING

Pump performance is adversely effected by increased suction lift, discharge elevation, and friction losses. See the performance curve and operating range shown on Page E-1 to be sure your overall application allows pump to operate within the safe operation range.

Materials

Either pipe or hose maybe used for suction and discharge lines; however, the materials must be compatible with the liquid being pumped. If hose is

used in suction lines, it must be the rigid-wall, reinforced type to prevent collapse under suction. Using piping couplings in suction lines is not recommended.

Line Configuration

Keep suction and discharge lines as straight as possible to minimize friction losses. Make minimum use of elbows and fittings, which substantially increase friction loss. If elbows are necessary, use the long-radius type to minimize friction loss.

Connections to Pump

Before tightening a connecting flange, align it exactly with the pump port. Never pull a pipe line into place by tightening the flange bolts and/or couplings.

Lines near the pump must be independently supported to avoid strain on the pump which could cause excessive vibration, decreased bearing life, and increased shaft and seal wear. If hose-type lines are used, they should have adequate support to secure them when filled with liquid and under pressure.

Gauges

The pump is drilled and tapped for installing discharge pressure and vacuum suction gauges. It is recommended that gauges be installed to monitor pump performance. Seal the gauge threads with pipe dope to ensure an airtight seal. Follow the sealant manufacturer's recommendations when selecting and applying the pipe dope. The pipe dope should be compatible with the liquid being pumped.

SUCTION LINES

To avoid air pockets which could affect pump priming, the suction line must be as short and direct as possible. When operation involves a suction lift, the line must always slope upward to the pump from the source of the liquid being pumped; if the line slopes down to the pump at any point along the suction run, air pockets will be created.

Fittings

Suction lines should be the same size as the pump inlet. If reducers are used in suction lines, they

should be the eccentric type, and should be installed with the flat part of the reducers uppermost to avoid creating air pockets. Valves are not normally used in suction lines, but if a valve is used, install it with the stem horizontal to avoid air pockets.

Strainers

Be certain to use the strainer furnished with the pump; any spherical solids which pass through the strainer will also pass through the pump itself.

If a strainer not furnished with the pump is installed by the pump user, make certain that the total area of the openings in the strainer is at least three or four times the cross section of the suction line, and that the openings will not permit passage of solids larger than the solids handling capability of the pump.

This pump is designed to handle up to 3 inch (76,2 mm) diameter spherical solids.

Sealing

Since even a slight leak will affect priming, head, and capacity, especially when operating with a high suction lift, all connections in the suction line should be sealed with pipe dope to ensure an airtight seal. Follow the sealant manufacturer's recommendations when selecting and applying the pipe dope. The pipe dope should be compatible with the liquid being pumped.

Suction Lines In Sumps

If a single suction line is installed in a sump, it should be positioned away from the wall of the sump at a distance equal to 1 1/2 times the diameter of the suction line.

If there is a liquid flow from an open pipe into the sump, the flow should be kept away from the suction inlet because the inflow will carry air down into the sump, and air entering the suction line will reduce pump efficiency.

If it is necessary to position inflow close to the suction inlet, install a baffle between the inflow and the suction inlet at a distance 1-1/2 times the diameter of the suction pipe. The baffle will allow entrained air to escape from the liquid before it is drawn into the suction inlet.

If two suction lines are installed in a single sump, the flow paths may interact, reducing the efficiency of one or both pumps. To avoid this, position the suction inlets so that they are separated by a distance equal to at least 3 times the diameter of the suction pipe.

Suction Line Positioning

The depth of submergence of the suction line is critical to **efficient** pump operation. Figure 2 shows recommended minimum submergence vs. velocity.

Although not recommended, the vacuum assisted priming feature allows the pump to be operated temporarily in a "slurping" application with varying water levels.

NOTE

The pipe submergence required may be reduced by installing a standard pipe increaser fitting at the end of the suction line. The larger opening size will reduce the inlet velocity. Calculate the required submergence using the following formula based on the increased opening size (area or diameter).

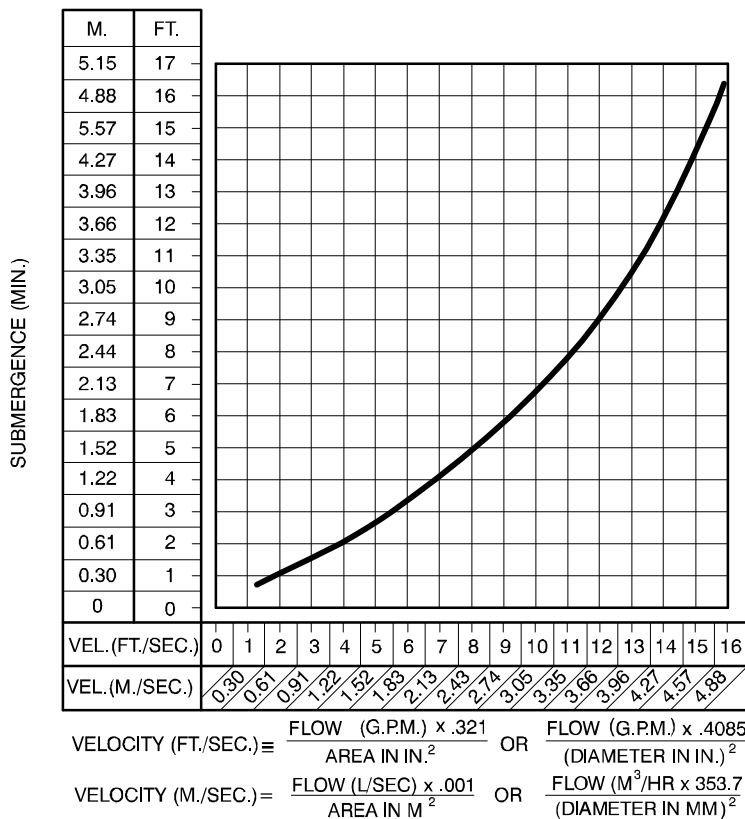

Figure 2. Recommended Minimum Suction Line Submergence vs. Velocity

DISCHARGE LINES

Siphoning

Do not terminate the discharge line at a level lower than that of the liquid being pumped unless a siphon breaker is used in the line. Otherwise, a siphoning action causing damage to the pump could result.

Valves

This pump is designed with a check valve in the discharge line.

If a throttling valve is desired in the discharge line, use a valve as large as the largest pipe to minimize friction losses. Never install a throttling valve in a suction line.

With high discharge heads, it is recommended that a throttling valve be installed in the discharge line to protect the pump from excessive shock pressure and reverse rotation when it is stopped.



If the application involves a high discharge head, gradually close the discharge throttling valve before stopping the pump.

ALIGNMENT

The alignment of the pump, air compressor and engine is critical for trouble-free mechanical operation. See Section E, **Securing Intermediate And Drive Assembly To Engine** in **MAINTENANCE AND REPAIR**, for details.

AUTO-START

The standard pump is equipped with an auto-start control system which allows the pump to start and stop as the liquid level in the wet well or sump rises and falls.

Refer to the information which follows for installation details for the liquid level sensing system provided with your pump.

Float Switch Installation

The Float Switch autostart system employs either a single or double float switch, where a bulb raises or lowers (floats) with the liquid level, thus activating an enclosed miniature switch. The floats are equipped with a socket type connector that plugs into a matching receptacle on the auto-start control box.

Standard floats are equipped with 50 feet (15,2 m) of cable.

When installing the floats, note the following:

- a. **Be sure** to provide sufficient room in the wet well or sump so that floats do not get obstructed or drawn into the suction line. If a flexible suction hose is used, it may be extended to lay along the bottom of the wet well or sump and the float can be attached to the hose above the point where it bends along the bottom. Direct the suction line toward the flow, and the float(s) away from the flow. If a stand-

pipe is available, attach the float switch cable to the standpipe in the sump at the approximate desired liquid level.

- b. In a single float system, the cable can be tethered to the suction line or standpipe approximately 6 inches (152 mm) above the float. This setting allows approximately 9 inches (229 mm) of liquid rise between pump start/stop. The start/stop interval may be increased by extending the float end of the cable. The liquid level in the sump will increase approximately 8 inches (203 mm) between start/stop intervals for every 6 inches (152 mm) of cable increase.
- c. If a double float switch system is used, position the "Start" float at the desired high water level in the sump, and the "Stop" float at the desired low water level in the pump.
- d. Refer to Figure 3 for additional float switch data.

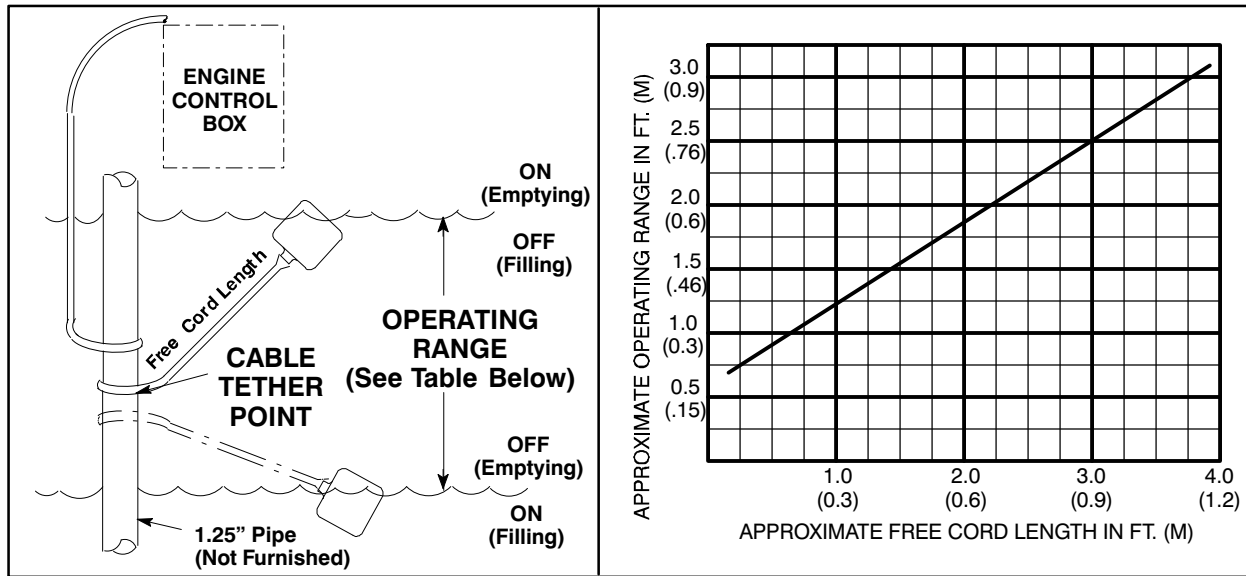

Figure 3. Float Switch Data

OPERATION – SECTION C

Review all **SAFETY** information in Section A.

Follow the instructions on all tags, labels and decals attached to the pump.



Do not operate an internal combustion engine in an explosive atmosphere. When operating an internal combustion engine in an enclosed area, make sure exhaust fumes are piped to the outside. These fumes contain carbon monoxide, a deadly gas that is colorless, tasteless and odorless.

OPERATION



This pump is designed to handle most non-volatile, non-flammable liquids containing specified entrained solids and corrosives. Do not attempt to pump volatile, corrosive, or flammable liquids which may damage the pump or endanger personnel as a result of pump failure.



Pump speed and operating condition points must be within the continuous performance range shown on the performance curve in Section E on page E-1.

PRIMING

Install the pump and piping as described in **INSTALLATION**. Make sure that the piping connections are tight, and that the pump is securely mounted. Check that the pump is properly lubri-

cated (see **LUBRICATION** in **MAINTENANCE AND REPAIR**).

The pump will begin to prime upon startup. The air in the suction line will be discharged from the educator discharge line. Complete priming is indicated by a positive discharge pressure reading.

If full priming is not achieved, the discharge check valve may be malfunctioning. If this occurs, shut down the pump and consult **Maintenance and Repair**, Section E for further details.

STARTING

Check the fuel level and oil levels in the engine, air compressor, pump bearings and seal housing.

Make sure the pump is level. Lower the jack stands and chock the wheels, if so equipped.



Make sure the pump is level. Lower jack stands and chock the wheels, if so equipped. Use caution when positioning the skid-mounted unit to prevent damage to the fuel tank.



This pump is equipped with automatic liquid level controls, and is subject to automatic restart. Keep hands and clothing away from the unit to prevent injury during automatic operation. Disconnect the positive battery cable before performing any maintenance. Failure to do so may result in serious personal injury.

Consult the engine operations manual before attempting to start the unit.

Manual Starting

On initial start-up, set the engine speed at the half-throttle position. Turn the keyswitch on the control

box to the “START” position until the engine starts. Release the key and the switch will return to the “RUN” position.

After the engine starts and the unit is fully primed, adjust the engine RPM until the desired flow rate is achieved.



Pump speed and operating condition points must be within the continuous performance range shown on the curve on Page E-1.

Automatic Starting

If the unit is to be operated with the autostart control system, install the float(s) as described in **INSTALLATION, Section B**.

Follow the procedures outlined for manual starting and throttle adjustment, then turn the key to the “AUTO START” position.

NOTE

For security purposes, the key can be removed with the switch in the “AUTO START” position.

Press and hold the white “AUTO” button on the control panel until the red “AUTO” light illuminates. The auto-start system is now armed.

NOTE

The unit can continue to be started manually with the keyswitch in the “AUTO START” position by pressing the white “MAN” button on the control. The “Single Lightning Bolt” light on the control will illuminate in conjunction with an audible alarm before the unit starts. The unit can then be stopped manually by pressing the “OFF/SET” button.

In the auto-start mode, the “Single Lightning Bolt” light will illuminate in conjunction with an audible alarm when the liquid level in the sump or wet well rises and activates the float(s). The light will blink

and the alarm will sound for approximately 8 seconds before the unit starts.

When the liquid level in the sump or wet well is sufficiently pumped down, the unit will automatically shut down.

NOTE

If the keyswitch is moved to the “OFF” position while in the auto-start mode, the engine will stop. However, the auto-start process will continue as soon as the keyswitch is moved back to the “AUTO START” position. To cancel the auto-start process, press the “OFF/SET” button.

The control panel is equipped with high oil temperature, low oil pressure, V-belt and start failure (3 attempts) safety shutdowns. If any of these problems occur, the red “Double Lightning Bolt” light will illuminate to indicate a system fault. When the problem is corrected, press the “OFF/SET” button to reset the control.

NOTE

The “OFF/SET” button has dual functionality when in program mode. If necessary, consult the factory for details on programming functions.

The unit can be started manually with the keyswitch in the “AUTO START” position by pressing the white “MAN” button. The “Single Lightning Bolt” light will illuminate in conjunction with an audible alarm before the unit starts.

Stop the unit manually by pressing the “OFF/SET” button.

Priming

The pump will begin to prime upon startup. The air in the suction line will be discharged from the educator discharge line. Complete priming is indicated by a positive discharge pressure reading.

If full priming is not achieved, the discharge check valve may be malfunctioning. If this occurs, shut down the pump and consult the separate **Maintenance and Repair** manual for further details.

Routine Operation



Do not operate an internal combustion engine in an explosive atmosphere. When operating an internal combustion engine in an enclosed area, make sure exhaust fumes are piped to the outside. These fumes contain carbon monoxide, a deadly gas that is colorless, tasteless and odorless.

Adjust the engine speed to achieve the desired output. Do not exceed the factory set engine speed and system operating pressure. Do not operate below the recommended operating speed (if applicable).



Never tamper with the governor to gain more power. The governor establishes safe operating limits that should not be exceeded. Refer to the Performance Curve in the separate Parts List Manual for the maximum continuous operating speed for this pump.

Operation In Extreme Heat

The safety shutdown system will automatically stop the unit if engine operating temperature exceeds design limits. If engine over-temperature shutdown occurs, allow the unit to cool before re-starting.

If engine overheating continues, check the engine lubricant level and viscosity. Consult the engine operation manual for the recommended lubricant for operation in extreme heat.

If the unit is being operated in the **automatic** mode, adjust the float(s) to allow shorter run and longer cooling periods, if possible.



This pump is equipped with automatic liquid level controls, and is subject to automatic restart. Keep hands and clothing away from the unit to prevent injury during automatic operation. Disconnect the battery before performing any maintenance. Failure to do so may result in serious personal injury.

OPERATIONAL CHECKS

Leakage

Once the pump is fully primed, no leakage should be visible at pump mating surfaces, or at pump connections or fittings. Keep all line connections and fittings tight to maintain maximum pump efficiency.

Pump Vacuum Check

Read the vacuum gauge with the pump primed and at operation speed. Shut off the pump. The vacuum gauge reading will immediately drop proportionate to static suction lift, and should then stabilize. If the vacuum reading falls off rapidly after stabilization, an air leak exists. Before checking for the source of the leak, check the point of installation of the vacuum gauge.

Liquid Temperature And Overheating

The **maximum** liquid temperature for this pump is 160° F (71°C). Do not apply it at a higher operating temperature.

Overheating can occur if operated with the valves in the suction or discharge lines closed. Operating against closed valves could bring the liquid to a boil, build pressure, and cause the pump to rupture or explode. If overheating occurs, stop the pump immediately and allow it to completely cool before servicing it. **Approach any over-heated pump cautiously.**



Allow an over-heated pump to com-

pletely cool before servicing. Do not remove plates, covers, gauges, or fittings from an overheated pump. Liquid within the pump can reach boiling temperatures, and vapor pressure within the pump can cause parts being disengaged to be ejected with great force. After the pump cools, drain the liquid from the pump by removing the casing drain plug. Use caution when removing the plug to prevent injury to personnel from hot liquid.

Strainer Check

Check the strainer regularly, and clean it as necessary. The strainer should also be checked if pump flow rate begins to drop. Monitor and record the vacuum suction gauge readings regularly to detect strainer blockage.

Never introduce air or steam pressure into the pump casing or piping to remove a blockage. This could result in personal injury or damage to the equipment. If backflushing is absolutely necessary, **liquid pressure** must be limited to 50% of the maximum permissible operating pressure shown on the pump performance curve.

STOPPING

Manual Stopping

Never halt the flow of liquid suddenly. If the liquid being pumped is stopped abruptly, damaging shock waves can be transmitted to the pump and piping system. Close all connecting valves slowly.

Reduce the throttle speed slowly and allow the engine to idle briefly before stopping.

In the manual mode, reduce the throttle speed slowly, and allow the engine to idle briefly before turning the key switch to 'OFF'.



If the application involves a high discharge head, gradually close the discharge throttling valve before stopping the pump.

After stopping the pump, switch off the engine ignition and remove the key to ensure that the pump will remain inoperative.

Automatic Stopping

In the automatic mode, the pump will stop when the liquid in the wet well or sump lowers and activates the "Off" float switch(s). The pump will restart automatically when the liquid rises and activates the "On" float switch(s).

Safety Shutdown System

The unit is equipped with a safety system to automatically shut down the engine under certain conditions. The engine will automatically shut down:

1. If the engine exceeds its safe operating temperature.
2. If the engine oil pressure drops below design limits.
3. If the engine fails to start within a pre-set period of time.
4. If the engine speed exceeds the safe operating range.
5. If the engine fan belt breaks.

Lights on the control panel will indicate which of the safety features has caused the engine to shut down.

Should any of the safety features cause the engine to shut down, **the cause must be determined and corrected** before putting the unit back into service. The engine **will not restart** until the key switch has been returned to the 'OFF' position for at least 10 seconds.

All safety shutdown features are pre-set at the factory for optimum performance and safety; **do not** attempt to adjust these settings.



Never disconnect any of the safety shutdown features; this will void the warranty and could result in serious damage to the unit and/or injury to personnel. Safe-

ty shutdown features are pre-set at the factory; do not attempt to adjust any of the settings. Determine the cause of shutdown before putting the unit back into service. Consult the factory for additional information.

PERIODIC CHECKS

Seal Cavity And Bearing Lubrication

Both the seal and bearing cavities were fully lubricated at the factory. Check the lubrication levels before startup, and regularly thereafter as indicated in Section E, **Maintenance and Repair**. When lubrication is required, use **only** SAE No. 30 non-detergent oil.

Bearing Temperature Check

Bearings normally run at higher than ambient temperatures because of heat generated by friction. Temperatures up to 160°F (71°C) are considered normal for bearings, and they can operate safely to at least 180°F (82°C).

Checking bearing temperatures by hand is inaccurate. Bearing temperatures can be measured accurately by placing a contact-type thermometer against the housing. Record this temperature for future reference.

A sudden increase in bearing temperatures is a warning that the bearings are at the point of failing to operate properly. Make certain that the bearing lubricant is of the proper viscosity and at the correct level (see **LUBRICATION** in Section E, **Maintenance and Repair**). Bearing overheating can also be caused by shaft misalignment and/or excessive vibration.

When pumps are first started, the bearings may seem to run at temperatures above normal. Continued operation should bring the temperatures down to normal levels.

Engine Fuel Filter

Consult the manual accompanying the engine, and change the fuel filter periodically as indicated. If operated under extremely dusty and/or humid conditions, change the filter more frequently. Irregular performance and loss of power usually indicate a dirty fuel filter.

Engine Oil

The engine was lubricated for test at the factory. However, **always** check the lubrication level before startup.

Consult the manual accompanying the engine, and change the oil filter periodically as indicated. If operated under extremely dusty conditions, change the filter more frequently.

Air Compressor

The air compressor was lubricated for test at the factory. However, **always** check the lubrication level before startup.

Consult the manual accompanying the air compressor and perform all duties and checks as indicated.

COLD WEATHER PRESERVATION

In below freezing conditions, drain the pump to prevent damage from freezing. Also, clean out any solids by flushing with a hose. Operate the pump for approximately one minute; this will remove any remaining liquid that could freeze the pump rotating parts. If the pump will be idle for more than a few hours, or if it has been pumping liquids containing a large amount of solids, drain the pump, and flush it thoroughly with clean water. To prevent large solids from clogging the drain port and preventing the pump from completely draining, insert a rod or stiff wire in the drain port, and agitate the liquid during the draining process. Clean out any remaining solids by flushing with a hose.

TROUBLESHOOTING – SECTION D

Review all SAFETY information in Section A.



Before attempting to open or service the pump:

1. Familiarize yourself with this manual.
2. Shut down the engine and disconnect the positive battery cable to ensure that the pump will remain inoperative.
3. Allow the pump to completely cool if overheated.
4. Check the temperature before opening any covers, plates, or plugs.

5. Close the suction and discharge valves.
6. Vent the pump slowly and cautiously.
7. Drain the pump.



This pump is equipped with an automatic starting system, and is subject to automatic restart. Keep hands and clothing away from the unit to prevent injury during automatic operation. Disconnect the positive battery cable before performing any maintenance. Failure to do so may result in serious personal injury.

TROUBLE	POSSIBLE CAUSE	PROBABLE REMEDY
PUMP FAILS TO PRIME	Discharge check valve contaminated, damaged, or unable to seat. Air leak in suction line. Lining of suction hose collapsed. Leaking or worn seal or pump gasket. Suction lift or discharge head too high. Air compressor damaged or belts broken. Strainer clogged.	Clean or replace check valve. Correct leak. Replace suction hose. Check pump vacuum. Replace leaking or worn seal or gasket. Check piping installation and install bypass line if needed. See INSTALLATION . Check and repair/replace. Check strainer and clean if necessary.
PUMP STOPS OR FAILS TO DELIVER RATED FLOW OR PRESSURE	Eductor clogged. Air leak in suction line. Lining of suction hose collapsed. Leaking or worn seal or pump gasket.	Check and clean eductor. Correct leak. Replace suction hose. Check pump vacuum. Replace leaking or worn seal or gasket.

TROUBLE	POSSIBLE CAUSE	PROBABLE REMEDY
PUMP STOPS OR FAILS TO DELIVER RATED FLOW OR PRESSURE (cont.)	<p>Strainer clogged.</p> <p>Discharge check valve clogged.</p> <p>Suction intake not submerged at proper level or sump too small.</p> <p>Impeller or other wearing parts worn or damaged.</p> <p>Impeller clogged.</p> <p>Discharge head too high.</p> <p>Suction lift too high.</p> <p>Pump speed too slow.</p> <p>Belt or flexible coupling broken.</p>	<p>Check strainer and clean if necessary.</p> <p>Check and clean check valve.</p> <p>Check installation and correct submergence as needed.</p> <p>Replace worn or damaged parts. Check that impeller is properly centered and rotates freely.</p> <p>Free impeller of debris.</p> <p>Install bypass line.</p> <p>Measure lift w/vacuum gauge. Reduce lift and/or friction losses in suction line.</p> <p>Check engine output; consult engine operation manual.</p> <p>Check and replace as necessary.</p>
PUMP REQUIRES TOO MUCH POWER	<p>Pump speed too high.</p> <p>Extreme ambient temperature.</p> <p>Discharge head too low.</p> <p>Fuel filter clogged.</p> <p>Liquid solution too thick.</p> <p>Fuel contaminated.</p> <p>Pump or jack shaft bearing(s) frozen.</p>	<p>Check engine output.</p> <p>Reduce pump output.</p> <p>Adjust discharge valve.</p> <p>Check & replace often in extreme operating conditions.</p> <p>Dilute if possible.</p> <p>Check and replace as required.</p> <p>Disassemble, check and replace bearing(s) as required..</p>
PUMP CLOGS FREQUENTLY	<p>Discharge flow too slow.</p> <p>Suction check valve or foot valve clogged or binding.</p> <p>Liquid solution too thick.</p>	<p>Open discharge valve fully to increase flow rate, and run engine at maximum governed speed.</p> <p>Clean valve.</p> <p>Dilute if possible.</p>
EXCESSIVE NOISE	<p>Cavitation in pump.</p> <p>Pumping entrained air.</p> <p>Pump or drive not securely mounted.</p> <p>Impeller clogged or damaged.</p>	<p>Reduce suction lift and/or friction losses in suction line. Record vacuum and pressure gauge readings and consult local representative or factory.</p> <p>Locate and eliminate source of air bubble.</p> <p>Secure mounting hardware.</p> <p>Clean out debris; replace damaged parts.</p>

TROUBLE	POSSIBLE CAUSE	PROBABLE REMEDY
BEARINGS RUN TOO HOT	Bearing temperature is high, but within limits. Low or incorrect lubricant. Suction and discharge lines not properly supported. Drive misaligned. Excessive tension on drive belt.	Check bearing temperature regularly to monitor any increase. Check for proper type and level of lubricant. Check piping installation for proper support. Align drive properly. Check belt tension. Adjust as required.

PREVENTIVE MAINTENANCE

Since pump applications are seldom identical, and pump wear is directly affected by such things as the abrasive qualities, pressure and temperature of the liquid being pumped, this section is intended only to provide general recommendations and practices for preventive maintenance. Regardless of the application however, following a routine preventive maintenance schedule will help assure trouble-free performance and long life from your Gorman-Rupp pump. For specific questions concerning your application, contact your Gorman-Rupp distributor or the Gorman-Rupp Company.

Record keeping is an essential component of a good preventive maintenance program. Changes in suction and discharge gauge readings (if so

equipped) between regularly scheduled inspections can indicate problems that can be corrected before system damage or catastrophic failure occurs. The appearance of wearing parts should also be documented at each inspection for comparison as well. Also, if records indicate that a certain part (such as the seal) fails at approximately the same duty cycle, the part can be checked and replaced before failure occurs, reducing unscheduled down time.

For new applications, a first inspection of wearing parts at 250 hours will give insight into the wear rate for your particular application. Subsequent inspections should be performed at the intervals shown on the chart below. Critical applications should be inspected more frequently.

Preventive Maintenance Schedule					
Item	Service Interval*				
	Daily	Weekly	Monthly	Semi-Annually	Annually
General Condition (Temperature, Unusual Noises or Vibrations, Cracks, Leaks, Loose Hardware, Etc.)	I				
Pump Performance (Gauges, Speed, Flow)	I				
Bearing Lubrication		I			R
Seal Lubrication (And Packing Adjustment, If So Equipped)		I			R
V-Belts (If So Equipped)			I		
Air Release Valve Plunger Rod (If So Equipped)			I	C	
Front Impeller Clearance (Wear Plate)				I	
Rear Impeller Clearance (Seal Plate)				I	
Check Valve					I
Pressure Relief Valve (If So Equipped)					C
Pump and Driver Alignment					I
Shaft Deflection					I
Bearings					I
Bearing Housing					I
Piping					I
Driver Lubrication – See Mfgr’s Literature					I

Legend:
 I = Inspect, Clean, Adjust, Repair or Replace as Necessary
 C = Clean
 R = Replace

* Service interval based on an intermittent duty cycle equal to approximately 4000 hours annually. Adjust schedule as required for lower or higher duty cycles or extreme operating conditions.

PUMP MAINTENANCE AND REPAIR – SECTION E

MAINTENANCE AND REPAIR OF THE WEARING PARTS OF THE PUMP WILL MAINTAIN PEAK OPERATING PERFORMANCE.

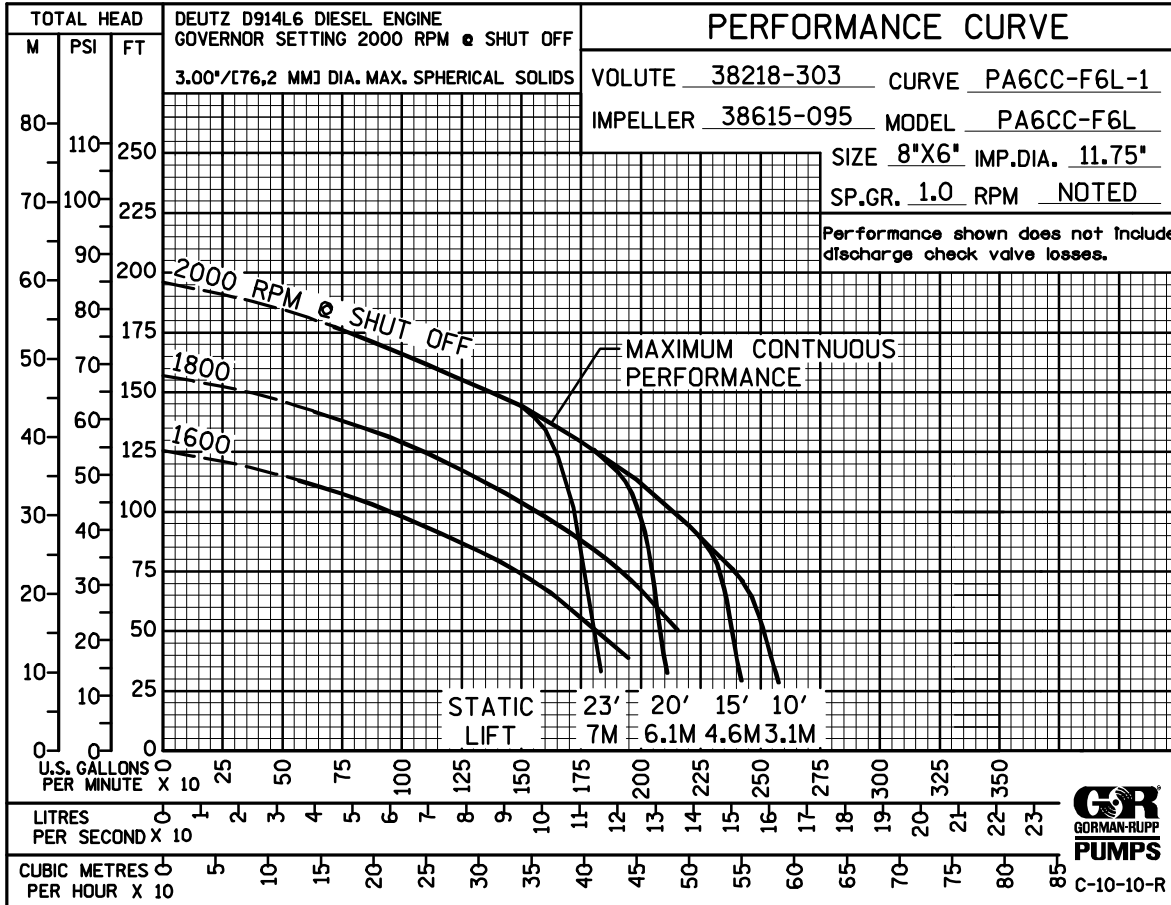

*** STANDARD PERFORMANCE FOR PUMP MODEL PA6C60C-F6L**

*Based on 70°F (21°C) clear water at sea level with minimum suction lift. Since pump installations are seldom identical, your performance may be different due to such factors as viscosity, specific gravity, elevation, temperature, and impeller trim.

Contact the Gorman-Rupp Company to verify performance or part numbers.

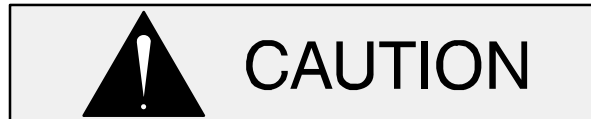

Pump speed and operating condition points must be within the continuous performance range shown on the curve.

If your pump serial number is followed by an "N", your pump is **NOT** a standard production model.

ILLUSTRATION

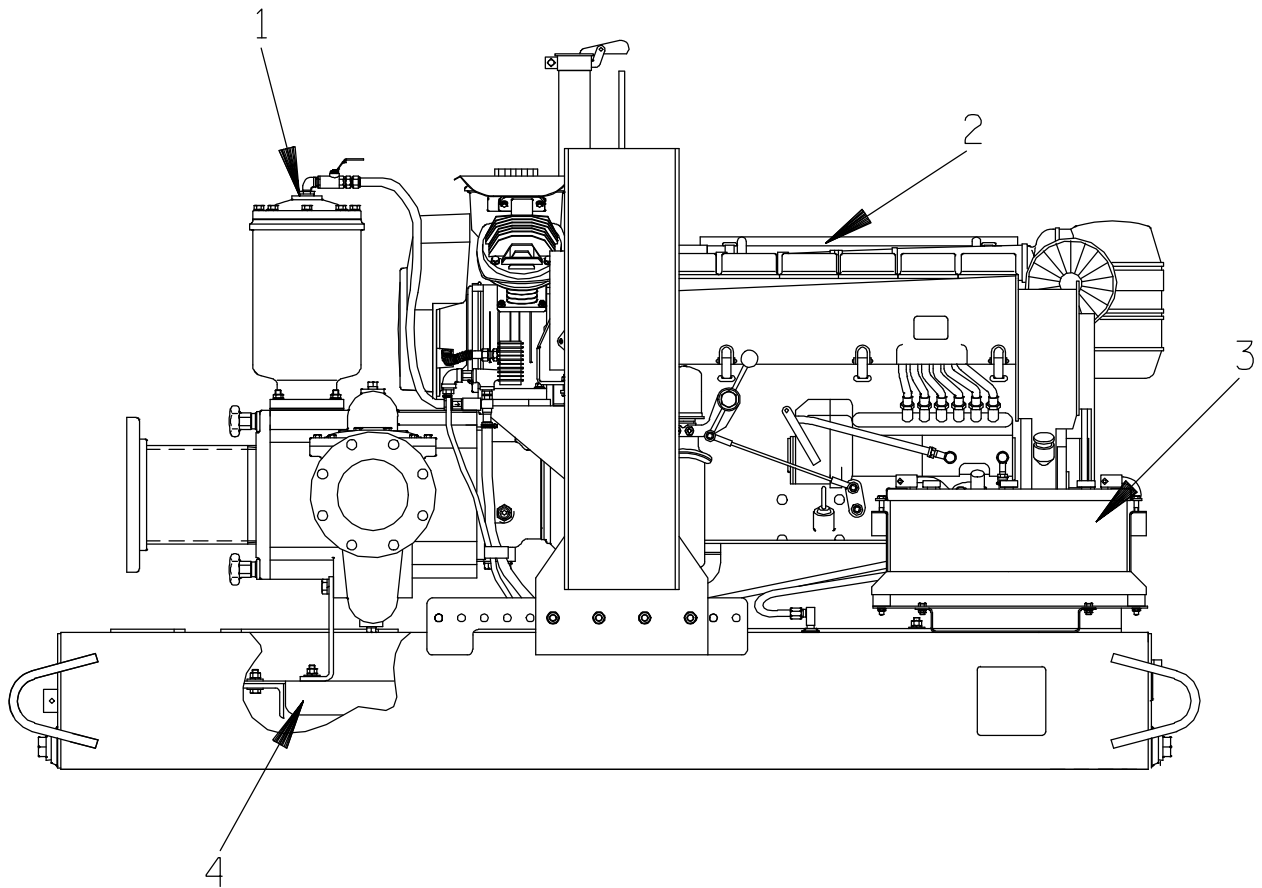

Figure 1. Pump Model PA6C60C-F6L

Pump Model PA6C60C-F6L
PARTS LIST

(From S/N 1477478 Up)

ITEM NO.	PART NAME	PART NUMBER	MAT'L CODE	QTY
1	PUMP END	PA6C60C-(SAE 3/11.5)	---	1
2	POWER UNIT KIT	46143-042	---	1
3	BATTERY	SEE OPTIONS	---	REF
4	PUMP MOUNTING KIT	48157-028	---	1
NOT SHOWN:				
	G-R DECAL	GR-06	---	3
	PRIME AIRE DECAL	38812-078	---	2
	PAPER INSTRUCTION TAG	38817-085	---	1
OPTIONAL:				
	DRY BATTERY	29331-506	---	1
	WET BATTERY	29331-526	---	1
	WHEEL KIT	GRP30-262	---	1

ILLUSTRATION

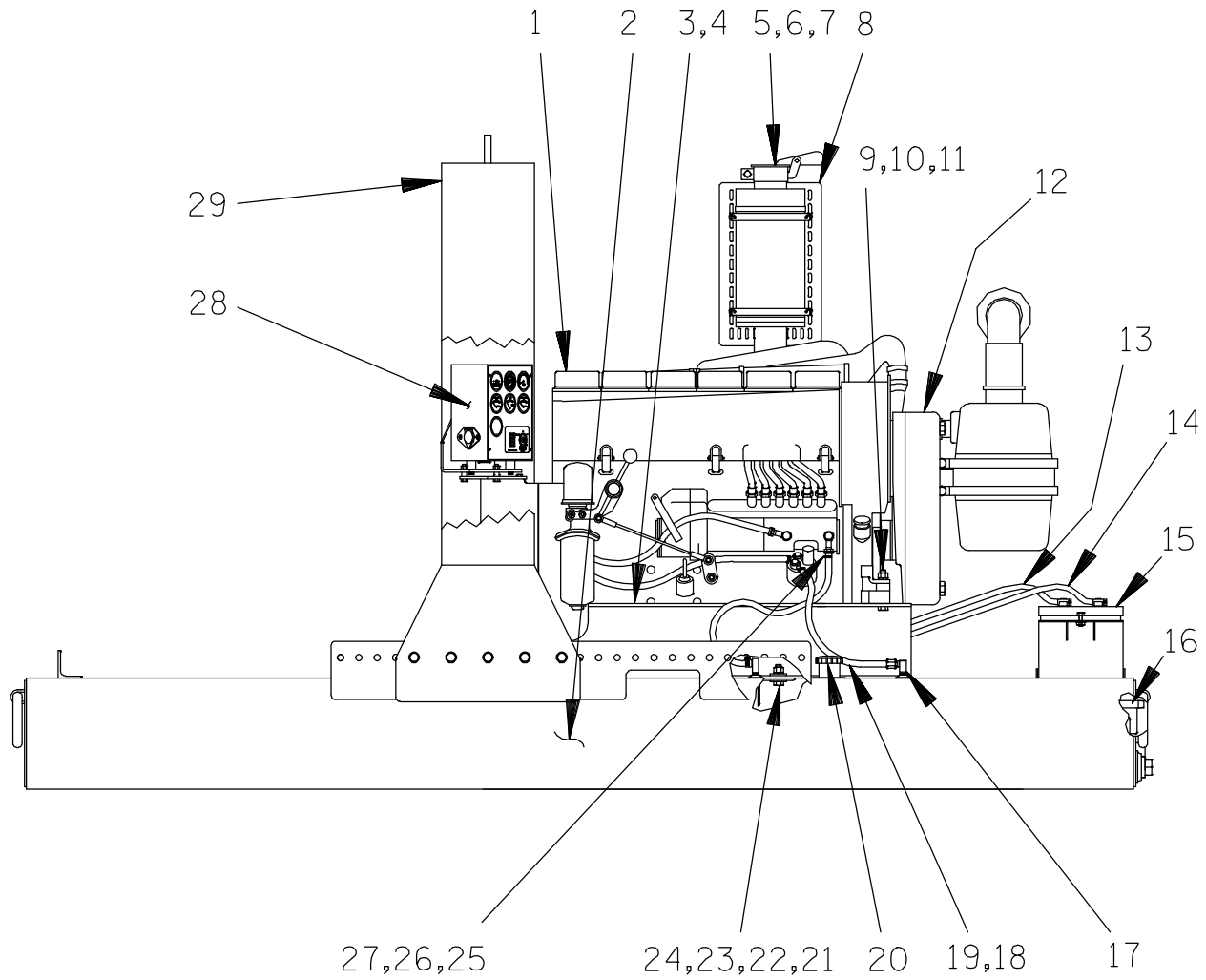

Figure 2. 46143-042 Power Unit Kit

PARTS LIST
46143-042 Power Unit Kit

ITEM NO.	PART NAME	PART NUMBER	MAT'L CODE	QTY
1	DEUTZ D914L6 ENGINE	29217-361	---	1
2	BASE/FUEL TANK	41553-007	24150	1
3	R.H. ENGINE RAIL	34458-038	15080	1
4	L.H. ENGINE RAIL	34441-069	15080	1
5	EXHAUST ELBOW	31912-036	15210	1
6	WEATHER CAP	S1387	---	1
7	MUFFLER ASSY	SUPPLIED W/ENGINE		1
8	MUFFLER GUARD ASSY	42331-035	---	1
9	HEX HD CAPSCREW	B0816	15991	4
10	HEX NUT	D08	15991	4
11	LOCK WASHER	J08	15991	4
12	BELT GUARD ASSY	SUPPLIED W/ENGINE		1
13	POS. BATTERY CABLE	47311-210	---	1
14	NEG. BATTERY CABLE	47311-142	---	1
15	BATTERY BOX KIT	42432-001	---	1
16	OIL DRAIN ASSY	46342-033	---	1
17	FUEL PICKUP	29332-145	---	2
18	HOSE ASSY	46341-796	---	1
19	MALE CONECTOR	S1447	---	1
20	FUEL GAUGE	29332-135	---	1
21	HEX HD CAPSCREW	B1007	15991	4
22	HEX NUT	D10	15991	4
23	LOCK WASHER	J10	15991	4
24	FLAT WASHER	K10	15991	8
25	3/8 I.D. X 48 IN. LG. HOSE	18513-302	---	1
26	HOSE CLAMP	26518-642	---	2
27	MALE NPT HOSE BARB	26523-333	---	2
28	CONTROL PANEL KIT	48313-794	---	1
29	LIFTING BAIL KIT	48274-801	---	1
NOT SHOWN:				
	FLOAT SWITCH	48312-980	---	1
	ENGINE STARTUP TAG	38816-269	---	1
	INSTRUCTION DECAL	38818-144	---	1
	WARNING DECAL	38816-203	---	4
	CAUTION DECAL	38816-169	---	1

ILLUSTRATION

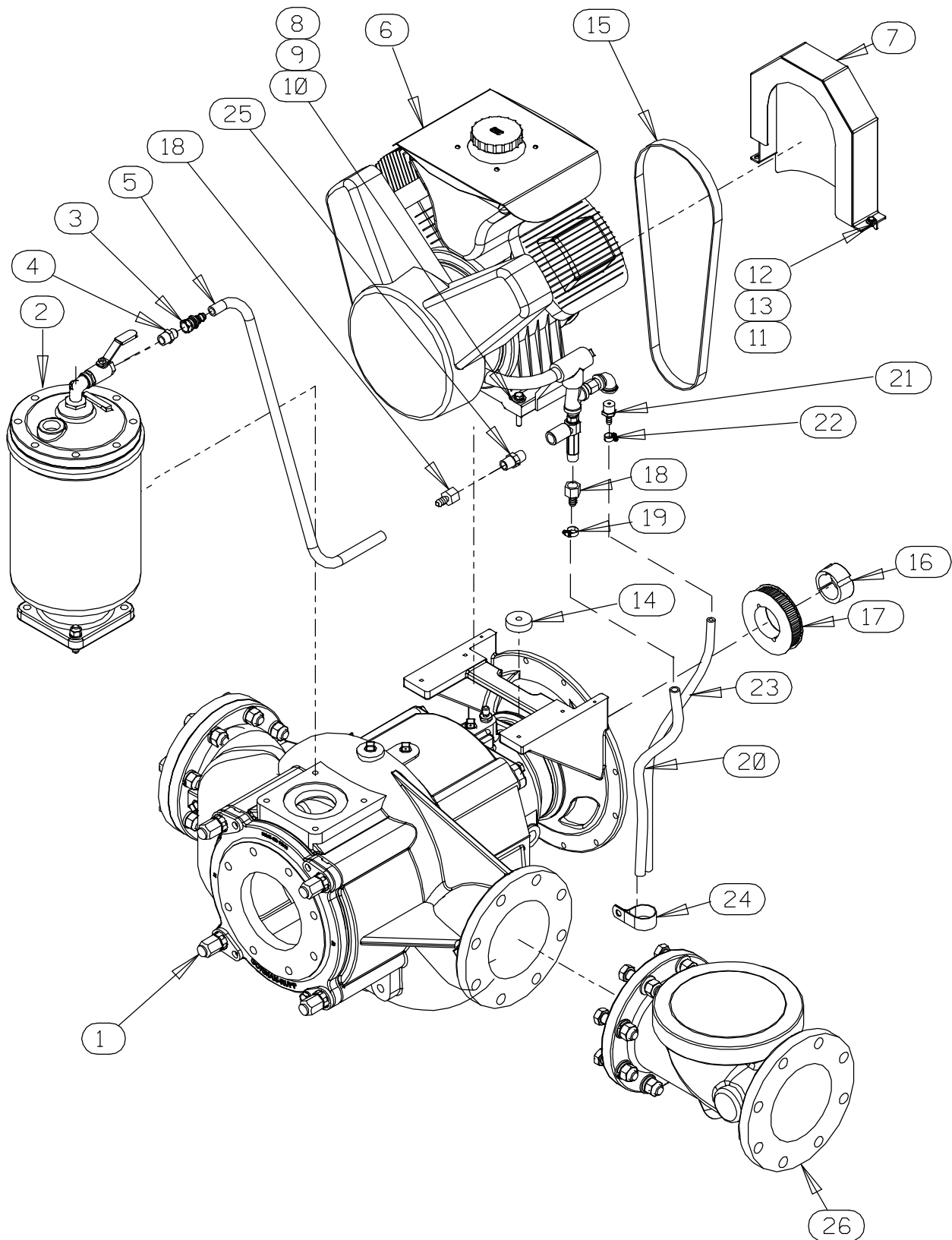

Figure 3. PA6C60C—(SAE 3/11.5) Pump Assembly

PA6C60C--(SAE 3/11.5) Pump Assembly

PARTS LIST

ITEM NO.	PART NAME	PART NUMBER	MAT'L CODE	QTY
1	PUMP END ASSEMBLY	66F60C--(SAE3/11.5)	----	1
2	PRIMING CHAMBER KIT	48275-005	----	1
3	HOSE BARB FITTING	26523-047	----	1
4	CONNECTOR	S1598	----	1
5	1/2" ID X 30" LG HOSE	18513-113	----	1
6	AIR COMPRESSOR ASSY	46181-906	----	1
7	BELT GUARD ASSY	42351-327	24150	1
8	HEX HEAD CAP SCREW	B0610	15991	4
9	LOCK WASHER	J06	15991	4
10	FLAT WASHER	K06	15991	4
11	HEX HEAD CAP SCREW	B0402	15991	2
12	FLAT WASHER	K04	15991	2
13	LOCK WASHER	J04	15991	2
14	SPACER	31141-034	15000	4
15	* SYNCHRONOUS BELT	24186-008	----	1
16	BUSHING	24131-498	----	1
17	SPROCKET	24271-112	----	1
18	HOSE BARB FITTING	26523-446	----	2
19	HOSE CLAMP	26518-666	----	1
20	1/2" ID X 20" LG HOSE	18513-113	----	1
21	HOSE BARB FITTING	26523-387	----	1
22	HOSE CLAMP	26518-642	----	1
23	3/8" ID X 24" LG HOSE	18513-302	----	1
24	CLAMP	27111-348	----	1
25	CHECK VALVE	26641-092	----	1
26	CHECK VALVE KIT 6"	48274-015	----	1
	-CHECK VALVE	26642-146	----	1
	* -FLAPPER	26688-001	----	1
	* -COVER O-RING	25152-377	----	1
	* -FLANGE GASKET	25113-036	----	1
NOT SHOWN:				
	8" STRAINER	46641-010	24150	1
	SUCTION STICKER	6588AG	----	1
	DISCHARGE STICKER	6588BJ	----	1
	WARNING DECAL	2613FE	----	1
	G-R DECAL	GR-06	----	1
	LUBE DECAL	11421A	----	1
	OIL LEVEL	38816-123	----	1
	ROTATION DECAL	2613M	----	1

* INDICATES PARTS RECOMMENDED FOR STOCK

ILLUSTRATION

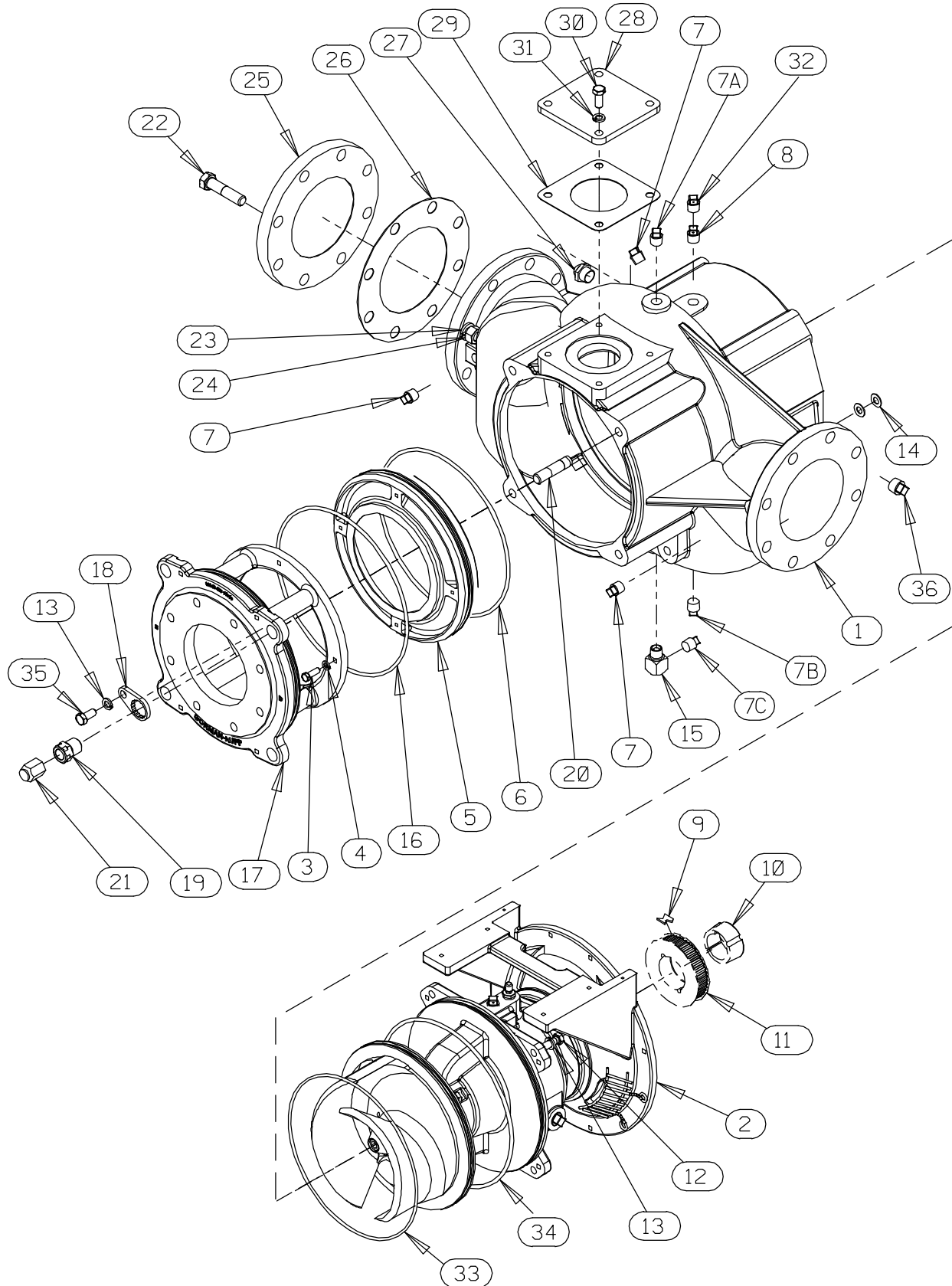

Figure 4. 66F60C—(SAE 3/11.5) Pump End Assembly

PARTS LIST
66F60C--(SAE 3/11.5) Pump End Assembly

ITEM NO.	PART NAME	PART NUMBER	MAT'L CODE	QTY
1	PUMP CASING	38218-303	11010	1
2	REPAIR ROTATING ASSY	44163-449	----	1
3	HEX HEAD CAP SCREW	B0604-1/2	17000	4
4	LOCK WASHER	J06	17090	4
5	* WEAR PLATE	38691-864	11010	1
6	* WEAR PLATE O-RING	25152-453	----	1
7	PIPE PLUG	P08	15079	3
7A	SEAL CAVITY FILL PLUG	P08	15079	1
7B	SEAL CAVITY DRAIN PLUG	P08	15079	1
7C	PUMP CASING DRAIN PLUG	P08	15079	1
8	VENTED PIPE PLUG	4823A	15079	1
9	* SYNCHRONOUS BELT	24186-008	----	1
10	BUSHING	24131-498	----	1
11	SPROCKET	24271-112	----	1
12	HEX HEAD CAP SCREW	B0806	15991	4
13	LOCK WASHER	J08	15991	8
14	* ROT ASSY ADJ SHIM	13131-3	17040	8
15	STREET ELBOW	25412-004	----	1
16	* BACK COVER PLATE O-RING	S1676	----	1
17	BACK COVER PLATE	38243-468	11010	1
18	LOCK COLLAR	38115-551	15001	4
19	ADJUSTING SCREW	31871-070	1500G	4
20	STUD	C1213	15991	4
21	BACK COVER NUT	31871-073	15000	4
22	HEX HEAD CAP SCREW	B1213	15991	8
23	LOCK WASHER	J12	15991	8
24	HEX NUT	D12	15991	8
25	BLIND FLANGE ASSEMBLY	42111-349	----	1
26	* GASKET	25113-036	----	1
27	SIGHT GAUGE	S1471	----	1
28	NOT USED			
29	NOT USED			
30	NOT USED			
31	NOT USED			
32	SHIPPING PLUG	11495B	15079	1
33	* SEAL PLATE O-RING	25152-381	----	1
34	* BEARING HOUSING O-RING	S1676	----	1
35	HEX HEAD CAP SCREW	B0804-1/2	15991	4
36	PIPE PLUG	P12	15079	1
NOT SHOWN:				
	DRIVE ASSEMBLY	44162-176	----	1
	SAE 3/10 ADAPTOR RING	3093	15080	1
	NAME PLATE	38818-127	13000	1
	DRIVE SCREW	BM#04-03	17000	4

* INDICATES PARTS RECOMMENDED FOR STOCK

ILLUSTRATION

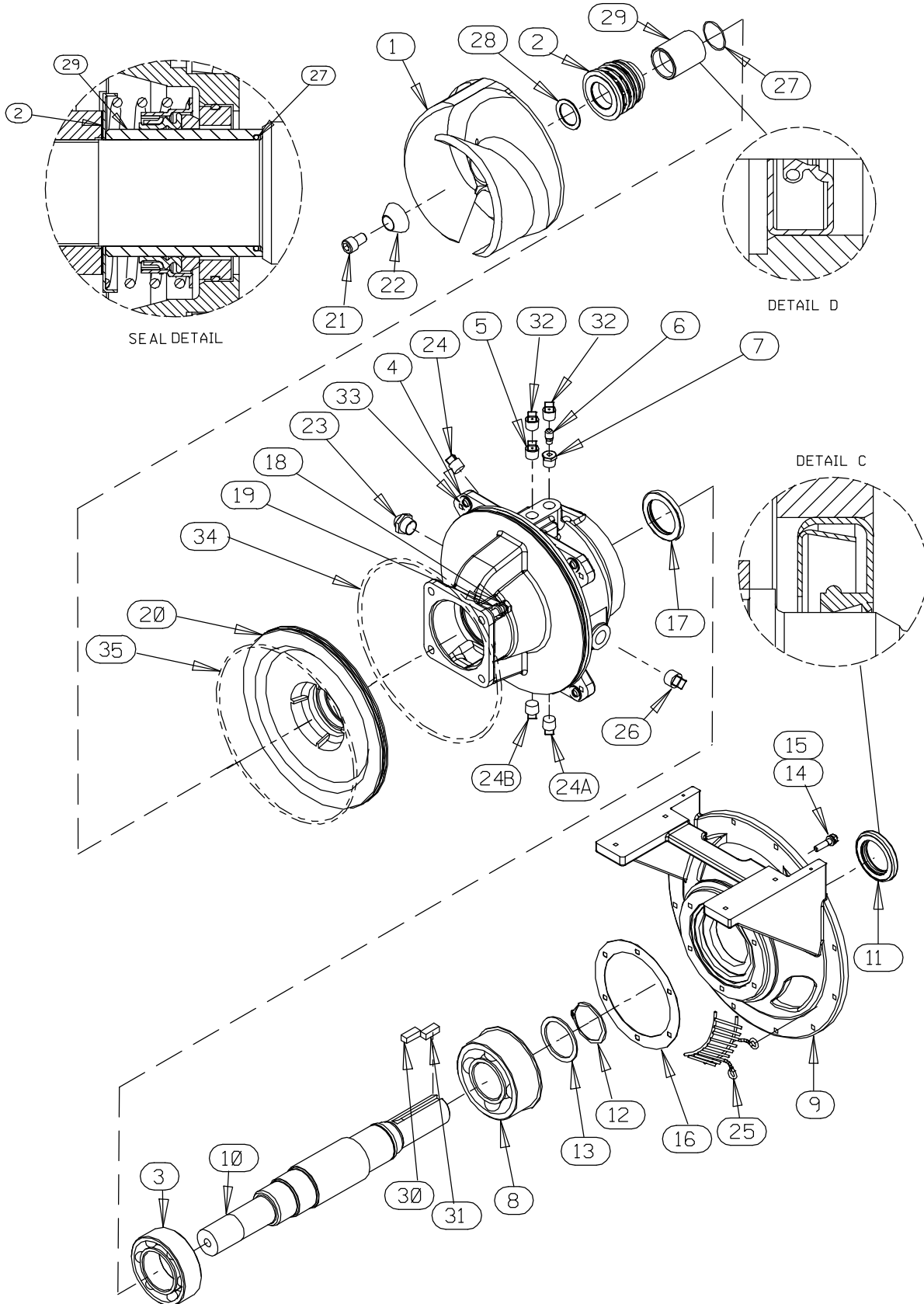

Figure 5. 44163-449 Repair Rotating Assembly

PARTS LIST
44163-449 Repair Rotating Assembly

ITEM NO.	PART NAME	PART NUMBER	MAT'L CODE	QTY
1	IMPELLER	38615-095	11010	1
2	* SEAL ASSEMBLY	46512-149	----	1
3	* BALL BEARING	23422-019		1
4	BEARING HOUSING	38251-513	10000	1
5	VENTED PIPE PLUG	4823A	15079	1
6	AIR VENT	S1530	----	1
7	REDUCER PIPE BUSHING	AP0802	15079	1
8	* BALL BEARING	23422-414	----	1
9	MOUNTING FLANGE	38545-009	11010	1
10	* IMPELLER SHAFT	38515-592	1706H	1
11	* OIL SEAL	S1907	----	1
12	RETAINING RING	S720	----	1
13	THRUST WASHER	31134-115	15000	1
14	HEX HEAD CAP SCREW	21632-937	----	6
15	LOCK WASHER	J06	15991	6
16	* GASKET	38683-474	18000	1
17	* OIL SEAL	25227-771	----	1
18	HEX HEAD CAP SCREW	B0805-1/2	15991	4
19	LOCK WASHER	J08	15991	4
20	SEAL PLATE	38272-256	10000	1
21	SOCKET HEAD CAP SCREW	DM1004S	17090	1
22	IMPELLER WASHER	31514-015	17000	1
23	SIGHT GAUGE	S1471	----	1
24	PIPE PLUG	P08	15079	1
24A	BEARING CAVITY DRAIN PLUG	P08	15079	1
24B	SEAL CAVITY DRAIN PLUG	P08	15079	1
25	INTERMEDIATE GUARD	42381-509	24152	2
26	PIPE PLUG	P12	15079	1
27	SHAFT SLEEVE O-RING	25154-131	----	REF
28	IMPELLER ADJ SHIM SET	48261-057	----	REF
29	SHAFT SLEEVE	31163-019	1706H	REF
30	KEY	24113-601	----	REF
31	* KEY	24113-603	----	1
32	SHIPPING PLUG	11495B	15079	2
33	ROT ASSY ADJ SHIM	13131-3	17040	8
34	* BEARING HOUSING O-RING	S1676	----	1
35	* SEAL PLATE O-RING	25152-381	----	1
NOT SHOWN:				
	INSTRUCTION TAG	6588U	----	1

* INDICATES PARTS RECOMMENDED FOR STOCK

ILLUSTRATION

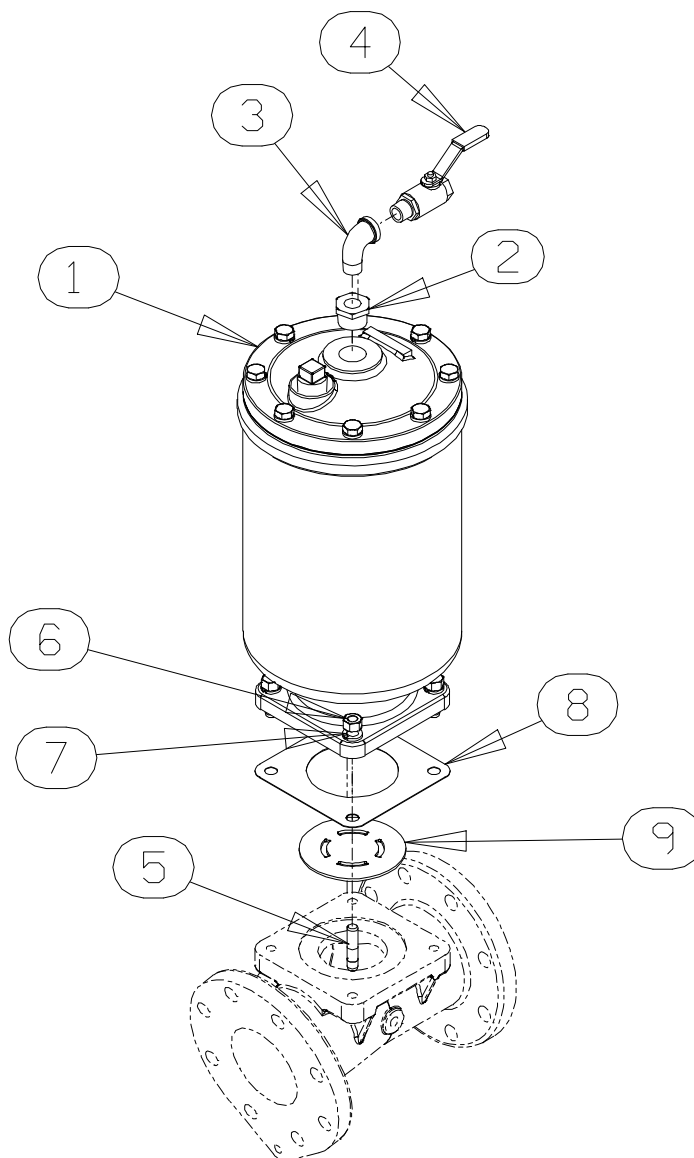

Figure 6. 48275-005 Priming Chamber Kit

ITEM NO.	PART NAME	PART NUMBER	MAT'L CODE	QTY
1	PRIMING CHAMBER ASSY	46112-709	---	1
2	PIPE BUSHING	AP1608	11999	1
3	STREET ELBOW	RS08	11999	1
4	BALL VALVE	26631-052	---	1
5	STUD	C0809	15991	4
6	HEX NUT	D08	15991	4
7	LOCK WASHER	J08	15991	4
8	* GASKET	38687-053	19060	1
9	BAFFLE	31113-011	17000	1

* INDICATES PARTS RECOMMENDED FOR STOCK

ILLUSTRATION

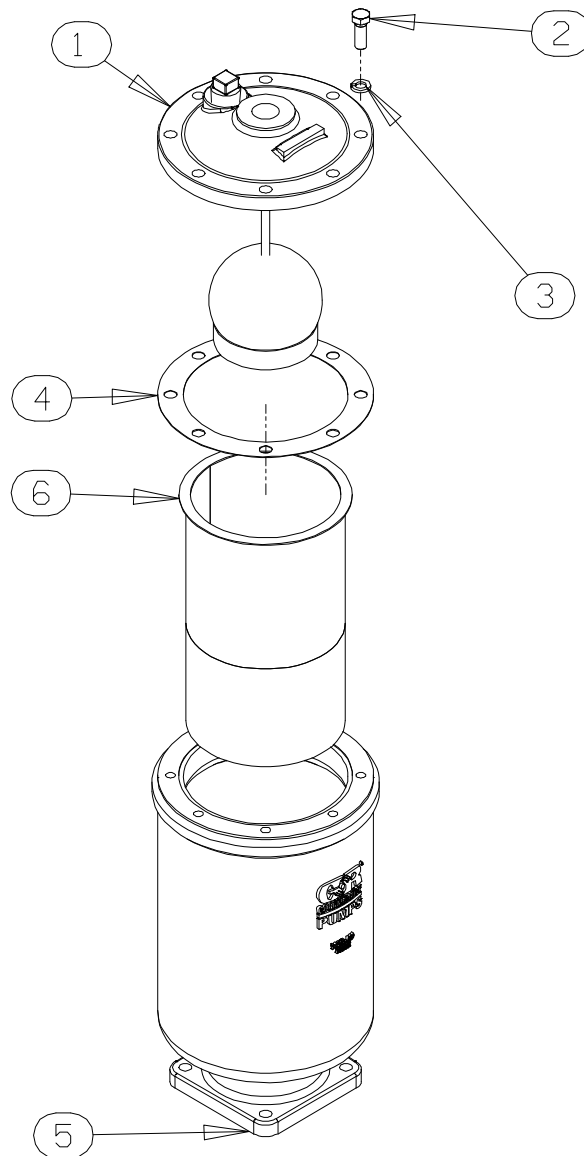

Figure 7. 46112-709 Priming Chamber Assembly

PARTS LIST

ITEM NO.	PART NAME	PART NUMBER	MAT'L CODE	QTY
1	PRIMING VALVE	26664-007	---	1
	-ORIFICE BUTTON	26688-021	---	1
2	HEX HD CAPSCREW	B0806	15991	8
3	LOCKWASHER	J08	15991	8
4	* PRIMING VALVE GASKET	38683-657	19060	1
5	PRIMING CHAMBER	38343-020	10000	1
6	STRAINER ASSY	46641-222	17000	1

* INDICATES PARTS RECOMMENDED FOR STOCK

ILLUSTRATION

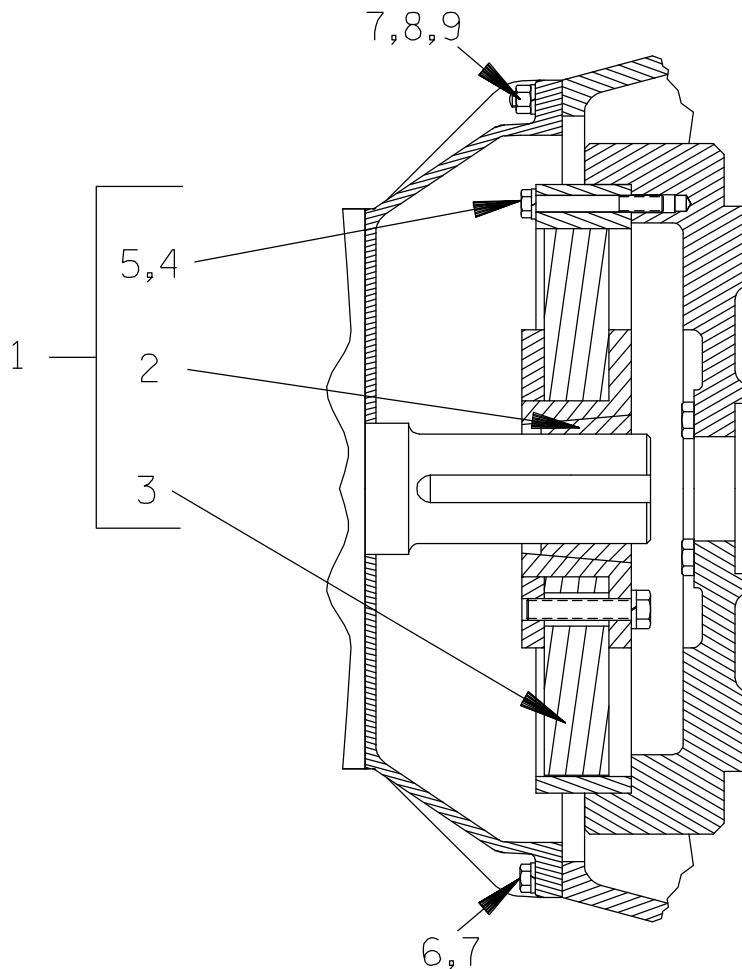











Figure 8. 44162-176 Drive Assembly

ITEM NO.	PART NAME	PART NUMBER	MAT'L CODE	QTY
1	COUPLING KIT	48112-019	---	1
2	-BUSHING	24131-498	---	1
3	-COUPLING ASSY	24391-102	---	1
4	-LOCK WASHER	21171-536	---	1
5	-SOC HEAD CAPSCREW	BD0606-1/2	15991	1
5	-SOC HEAD CAPSCREW	22644-220	---	1
6	 HEX HEAD CAPSCREW	B0606	15991	10
6	 HEX HEAD CAPSCREW	22645-166	---	10
7	 LOCK WASHER	J06	15991	12
7	 LOCK WASHER	21171-511	---	12
8	 STUD	C0606	15991	2
8	 STUD	26821-879	---	2
9	 HEX NUT	D06	15991	2
9	 HEX NUT	26821-932	---	2
	 FOR SAE APPLICATIONS			
	 FOR METRIC APPLICATIONS			

PUMP AND SEAL DISASSEMBLY AND REASSEMBLY

Review all **SAFETY** information in Section A.

Follow the instructions on all tags, label and decals attached to the pump.

This pump requires little service due to its rugged, minimum-maintenance design. However, if it becomes necessary to inspect or replace the wearing parts, follow these instructions which are keyed to the illustrations (see Figures 1 through 8) and the corresponding parts lists. Maintenance and repair instructions for the air compressor are covered separately in the specific literature supplied by the manufacturer.

Some pump service functions may be performed without separating the pump end assembly from the engine. However, the priming chamber (2, Figure 1) and discharge check valve assembly (26, Figure 1) must be removed to service most pump components. The following instructions assume complete disassembly of the pump is required.

Before attempting to service the pump, shut down the engine and take precautions to ensure that it will remain inoperative. Close all valves in the suction and discharge lines and drain the pump casing by removing the casing drain plug (7C, Figure 2). Clean and reinstall the drain plug.



This manual will alert personnel to known procedures which require special attention, to those which could damage equipment, and to those which could be dangerous to personnel. However, this manual cannot possibly anticipate and provide detailed instructions and precautions for every situation that might occur during maintenance of the unit. Therefore, it is the responsibility of the owner/maintenance personnel to ensure that only safe, established maintenance procedures are used, and that any procedures not addressed in this

manual are performed only after establishing that neither personal safety nor pump integrity are compromised by such practices.



Before attempting to open or service the pump:

1. Familiarize yourself with this manual.
2. Shut down the engine and disconnect the positive battery cable to ensure that the pump will remain inoperative.
3. Allow the pump to completely cool if overheated.
4. Check the temperature and make sure it is cool before opening any covers, plates, gauges, or plugs.
5. Close the suction and discharge valves.
6. Vent the pump slowly and cautiously.
7. Drain the pump.



The pump may be equipped with an automatic starting system, and therefore subject to automatic restart. Keep hands and clothing away from the unit to prevent injury during automatic operation. Disconnect the positive battery cable before performing any maintenance. Failure to do so may result in serious personal injury.



Use only replacement parts provided or approved by Gorman-Rupp. Use of non-authorized parts may result in damage to the equipment and/or injury to personnel and will invalidate the warranty.

Priming Chamber Removal And Disassembly

(Figure 6)

Disconnect both the suction piping and the air discharge tubing from the priming chamber assembly (1). Support the priming chamber assembly using a sling and a suitable lifting device. Remove the hardware (6 and 7) and separate the priming chamber assembly, gasket (8) and baffle (9) from the pump assembly.

(Figure 7)

Remove the hardware (2 and 3) securing the priming valve (1) to the priming chamber (5). Carefully lift the valve components from the priming chamber. Remove the gasket (4) and clean the mating surfaces.

If the priming valve float is stuck or the strainer (6) is clogged, it can usually be cleaned without further disassembly.

The only serviceable part of the priming valve is the orifice button (not shown). If liquid continues to bypass through the priming chamber after adjusting the orifice button (see **Priming Chamber Reassembly and Installation** for adjustment), the button may require replacement. To replace the orifice button, remove one of the “e-clips” from the pivot pin closest to the orifice button and remove the pivot pin. This will allow the linkage to be raised high enough to access the orifice button.

Remove the hex nut and lockwasher securing the orifice button to the linkage bar and unscrew the orifice button from the linkage bar.

Discharge Check Valve Removal and Disassembly

(Figure 3)

Remove the hardware (not shown) securing the discharge check valve bracket to the base.

Support the discharge check valve assembly (26) using a sling and a suitable lifting device. Remove the hardware (not shown) and separate the discharge check valve assembly and gasket (not shown) from the pump assembly (1).

The flapper and cover O-ring are the only serviceable parts of the check valve. If the flapper requires replacement, remove the hardware securing the cover. Separate the cover and O-ring and remove the flapper.

Back Cover Plate and Wear Plate Removal

(Figure 4)

The wear plate (5) is easily accessible and may be serviced by removing the back cover (17). Before attempting to service the pump, remove the pump casing drain plug (7C) and drain the pump. Clean and reinstall the drain plug.

Remove the back cover knobs (21) and pry the back cover and assembled wear plate from the pump casing (1).

NOTE

An alternate method of removing the back cover from the pump casing is to remove the back cover knobs (21) and two diagonally opposing locking collars (18). Use the adjusting screws (19) to press the back cover out of the pump casing.

Remove and discard the O-rings (6 and 16).

Inspect the wear plate and, if replacement is required, remove the hardware (3 and 4) securing it to the back cover plate.

Separating Pump and Drive Assembly From Engine

(Figure 3)

The pump and drive assembly must be separated from the engine before further disassembly.

Disengage the hardware (11, 12 and 13) and remove the belt guard assembly (7). Remove the hardware (8, 9 and 10) securing the air compressor assembly (6) to the mounting flange (9, Figure 5). Use a pry bar to raise the air compressor high enough to remove the spacers (14). Remove the synchronous belt (15) from the air compressor drive sheave (17).

Disconnect all hoses and fittings from the air compressor and use a suitable hoist and sling to remove the air compressor assembly.

(Figure 8)

Support the pump end using a hoist and sling, and remove the hardware (not shown) securing the pump casing to the base.

Remove the hardware (6, 7 and 9) securing the mounting flange (9, Figure 5) to the engine bellhousing. Remove the intermediate guards (25, Figure 5) and separate the assemblies by pulling the pump straight away from the engine. The bellhousing adaptor ring (not shown) will become a free part.

As the assemblies separate, the flexible portion of the coupling assembly (1) will remain on the shaft. To remove the coupling from the shaft, unscrew the two allen head setscrews from the bushing (2). Screw one of the setscrews into the puller hole on the circumference of the bushing. As the coupling and bushing separate, remove the bushing, and slide the coupling off the shaft. Remove the shaft key (3).

It is not necessary to remove the outer ring of the coupling from the engine flywheel unless the coupling must be replaced. To remove the ring, disengage the hardware (6 and 7) securing it to the flywheel.

Remove any leveling shims used under the casing mounting feet. Tie and tag the shims for ease of reassembly.

Move the pump end to a clean, well equipped shop area for further disassembly.

(Figure 4)

Remove the belt (15, Figure 3). Remove the capscrews from the center of the bushing (10). Reinstall the capscrews in the tapped holes in the bushing and tighten them in an alternating pattern until the bushing is “jacked” out of the sheave (11). Slide

the bushing and sheave off the shaft. Remove the key (30, Figure 5).

Draining Oil From Seal Cavity**(Figures 4 and 5)**

If any further disassembly is to be performed on the pump, the seal oil cavity must be drained to prevent the oil in the seal cavity from escaping as the pump casing is removed.

Position a large (3 gallon, minimum) **clean** container under the seal cavity drain plugs (7, Figure 4 and 24B, Figure 5). Remove the plugs and drain the oil from the seal cavity into the container. For shorter drain time, remove the vented plug (5, Figure 5). Clean and reinstall the drain plugs and vent plug. Inspect the oil for water, dirt or a cloudy condition which could indicate seal failure.

Loosening Impeller**(Figure 5)**

With the pump end separated from the engine, wedge a block of wood between the vanes of the impeller (1) and the pump casing (1) to prevent rotation. Remove the impeller screw and washer (21 and 22).

Install the shaft key (31) in the shaft keyway. Install a lathe dog on the drive end of the shaft (10) with the “V” notch positioned over the shaft key.

With the impeller rotation still blocked, see Figure 9 and use a long piece of heavy bar stock to pry against the arm of the lathe dog in a counterclockwise direction (when facing the drive end of the shaft). **Use caution** not to damage the shaft or keyway. When the impeller breaks loose, remove the lathe dog, key and wood block.

NOTE

Do not remove the impeller until the rotating assembly has been removed from the pump casing.

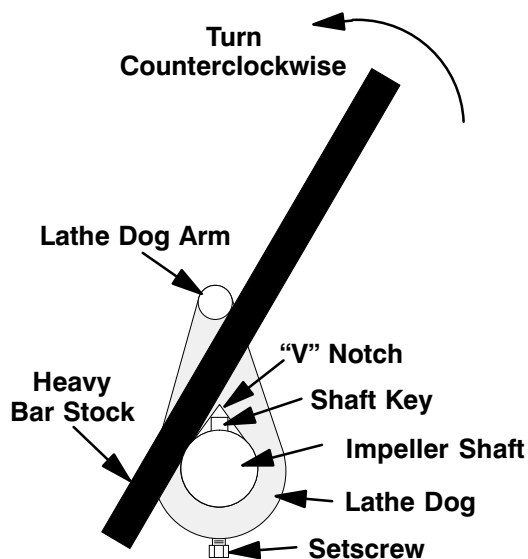

Figure 9. Loosening Impeller

Pump Casing Removal

(Figure 4)

Support the pump casing using a suitable hoist and sling.



Use lifting and moving equipment in good repair and with adequate capacity to prevent injuries to personnel or damage to equipment. If slings or chains are used to move the pump or components, make sure that the load is balanced; otherwise serious personal injury or death could result. Suction and discharge hoses and piping must be removed from the pump before lifting.

NOTE

*Drain the oil from the seal cavity before removing the pump casing. See **Draining Oil From Seal Cavity**.*

Remove the hardware (12 and 13) securing the pump casing (1) to the rotating assembly (2). Pull the pump casing straight away from the rotating assembly to prevent binding on the impeller. Re-

move the shims (14) and clean the contacting surfaces. Tie and tag the shims or measure and record their thickness for ease of reassembly.

Impeller Removal

(Figure 5)

With the rotating assembly removed from the pump casing, unscrew the impeller (1) in a counterclockwise direction (when facing the impeller). Use caution when unscrewing the impeller; tension on the shaft seal spring will be released as the impeller is removed. Inspect the impeller and replace if cracked or badly worn.

Remove the impeller adjusting shims (33); tie and tag the shims, or measure and record their thickness for ease of reassembly.

Seal Removal

(Figures 5 and 11)

Remove the spring centering washer and seal spring. Slide the shaft sleeve (29) and rotating portion of the seal (consisting of the bellows, retainer, and rotating element) off the shaft as a unit.

Apply oil to the sleeve and work it up under the rubber bellows. Slide the rotating portion of the seal off the sleeve.

Slide a pair of stiff wires with hooked ends along the shaft and hook the stationary seat from the back side. Pull the stationary seat and O-ring from the seal plate.

An alternate method of removing the stationary seal components is to remove the hardware (18 and 19) and separate the seal plate from the bearing housing (4). Position the seal plate on a flat surface with the impeller side down. Use a wooden dowel or other suitable tool to press on the back side of the stationary seat until the seat and O-ring can be removed.

Remove the shaft sleeve O-ring (27) and seal plate O-ring (34).

If no further disassembly is required, refer to **Seal Installation**.

Shaft and Bearing Removal and Disassembly

(Figure 5)

When the pump is properly operated and maintained, the bearing housing should not require disassembly. Disassemble the shaft and bearings **only** when there is evidence of wear or damage.



Shaft and bearing disassembly in the field is not recommended. These operations should be performed only in a properly equipped shop by qualified personnel.

Remove the bearing housing drain plug (24A) and drain the lubricant. Clean and reinstall the drain plug.

Disengage the hardware (14 and 15) and remove the mounting flange (9), gasket (16) and oil seal (11). Use a suitably sized dowel to press the oil seal from the mounting flange.

Place a block of wood against the impeller end of the shaft (10) and tap the shaft and assembled bearings (3 and 8) from the bearing housing. Press the oil seal (17) from the bearing housing.

Remove the bearing housing O-ring (34).

After removing the shaft and bearings, clean and inspect the bearings **in place** as follows.



To prevent damage during removal from the shaft, it is recommended that bearings be cleaned and inspected **in place**. It is **strongly** recommended that the bearings be replaced **any** time the shaft and bearings are removed.

Clean the bearing housing, shaft and all component parts (except the bearings) with a soft cloth soaked in cleaning solvent. Inspect the parts for wear or damage and replace as necessary.



Most cleaning solvents are toxic and flammable. Use them only in a well ventilated area free from excessive heat, sparks, and flame. Read and follow all precautions printed on solvent containers.

Clean the bearings thoroughly in **fresh** cleaning solvent. Dry the bearings with filtered compressed air and coat with light oil.



Bearings must be kept free of all dirt and foreign material. Failure to do so will greatly shorten bearing life. **Do not** spin dry bearings. This may scratch the balls or races and cause premature bearing failure.

Rotate the bearings by hand to check for roughness or binding and inspect the bearing balls. If rotation is rough or the bearing balls are discolored, replace the bearings.

The bearing tolerances provide a tight press fit onto the shaft and a snug slip fit into the bearing housing. Replace the bearings, shaft, or bearing housing if the proper bearing fit is not achieved.

If bearing replacement is required, remove the snap ring and thrust washer (12 and 13) and use a bearing puller to remove the inboard and outboard bearings from the shaft.

Shaft and Bearing Reassembly and Installation

(Figure 5)

Inspect the shaft (10) for distortion, nicks or scratches, or for thread damage on the impeller end. Dress small nicks and burrs with a fine file or emery cloth. Replace the shaft if defective.

Clean and inspect the bearings as indicated in **Shaft And Bearing Removal And Disassembly**.



To prevent damage during removal from the shaft, it is recommended that bearings be cleaned and inspected **in place**. It is **strongly** recommended that the bearings be replaced **any** time the shaft and bearings are removed.

NOTE

*The inboard bearing (3) comes from the manufacturer with a retaining ring installed on the bearing O.D. This retaining ring **must** be removed prior to installation.*

The bearings may be heated to ease installation. An induction heater, hot oil bath, electric oven, or hot plate may be used to heat the bearings. Bearings should **never** be heated with a direct flame or directly on a hot plate.

NOTE

*If a hot oil bath is used to heat the bearings, both the oil and the container must be **absolutely** clean. If the oil has been previously used, it must be **thoroughly** filtered.*

Heat the bearings to a uniform temperature **no higher than** 250°F (120°C) and slide the bearings onto the shaft, one at a time, until they are fully seated. This should be done quickly, in one continuous motion, to prevent the bearings from cooling and sticking on the shaft.

NOTE

Position the outboard bearing (8) on the shaft with the integral O.D. retaining ring positioned toward the drive end of the shaft.

After the bearings have been installed and allowed to cool, check to ensure that they have not moved away from the shaft shoulders in shrinking. If movement has occurred, use a suitably sized sleeve and a press to reposition the bearings against the shaft shoulders.

If heating the bearings is not practical, use a suitably sized sleeve and an arbor (or hydraulic) press to install the bearings on the shaft.



When installing the bearings onto the shaft, **never** press or hit against the outer race, balls, or ball cage. Press **only** on the inner race.

Install the thrust washer (13) and secure the outboard bearing (8) to the shaft with the snap ring (12).

Apply a light coating of oil to the lip of the oil seal (17) and press it into the bearing housing bore with the lip positioned as shown in Figure 5. Press the oil seal into the housing until the face is **just flush** with the machined surface on the housing.

Slide the shaft and assembled bearings into the bearing housing until the retaining ring on the outboard bearing seats against the bearing housing. Use caution not to damage the lip of the oil seal (17) on the shaft threads.

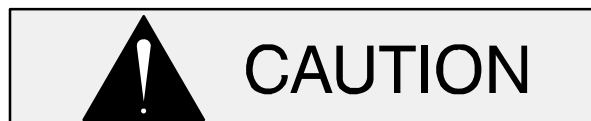

When installing the shaft and bearings into the bearing bore, push against the outer race. **Never** hit the balls or ball cage.

Apply a light coating of oil to the lip of the oil seal (11) and press it into the mounting flange (9) with the lip positioned as shown in Figure 5. The face of the oil seal should be just flush with the outer face of the mounting flange.

Install the drive flange gasket (16). Apply “Loctite Threadlocker No. 242” or equivalent compound on the threads of the capscrews (14). Install the lockwashers (14) and secure the drive flange to the bearing housing by torquing the capscrews to 40 ft. lbs. (480 in. lbs. or 5,5 m. kg.). **Be careful** not to damage the lip of the oil seal (11) on the shaft keyway.

Lubricate a new bearing housing O-ring (37) with grease and install it in the groove in the bearing housing.

Lubricate the bearings as indicated in **LUBRICATION** at the end of this section.

Securing Bearing Housing And Drive Assembly To Engine

(Figure 4)

Install the key (30 Figure 5) in the shaft keyway, making sure to leave room in the keyway for the drive key (31, Figure 5). Install the bushing (10) and sheave (11) on the shaft to the dimension shown in Figure 10.

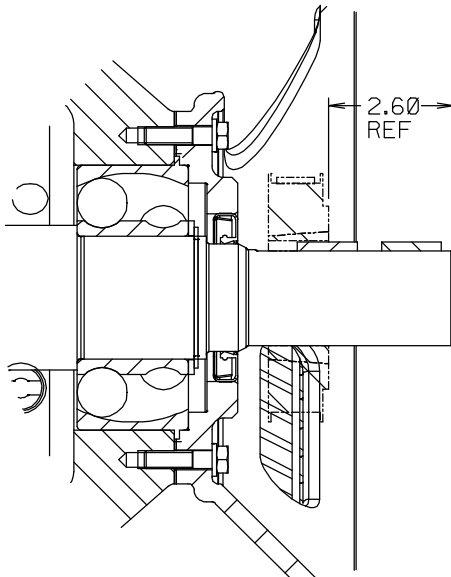

Figure 10. Compressor Drive Sprocket Positioning

NOTE

When properly installed to the dimension shown in Figure 9, the key (30, Figure 3) **will not** extend fully through the bushing. This is an acceptable fit for this application.

Secure the bushing and sheave to the shaft by torquing the bushing screws to 23 ft. lbs. (280 in. lbs. or 3,2 m. kg.) max. Install the belt (9) over the sheave and up through the slot in the mounting flange (9, Figure 5).

(Figure 8)

Install the shaft key (35, Figure 5) in the shaft keyway. Position the flexible portion of the coupling assembly (1) on the shaft as shown in Figure 8.

NOTE

The flexible portion of the coupling must be properly positioned on the shaft. The heads of the capscrews in the center of the coupling **must be positioned away from the pump.**

Align the keyway in the bushing (2) with the shaft key, and slide it onto the shaft to the dimension listed below. Rotate the flexible portion of the coupling until the tapped holes for the two setscrews align with those in the bushing, and install the setscrews.



Make certain that the flexible portion of the coupling is mounted as shown in Figure 8. **This dimension is critical.** If the coupling is not properly positioned on the shaft, the coupling parts may not fully engage, or a pre-load condition can cause premature bearing failure.

The coupling must be positioned **1.44 inch (37 mm)** from the end of the shaft. This will allow the two portions of the coupling to fully engage when the intermediate is secured to the engine bellhousing, without pre-loading the bearings.

With the flexible portion of the coupling and the bushing properly positioned on the shaft, tighten the two setscrews in an alternating sequence until the bushing and coupling are fully secured. Torque the setscrews to 23 ft. lbs. (280 in. lbs. or 3 m. kg.).

If the complete coupling assembly is being replaced, apply 'Loctite Retaining Compound No. 242' or equivalent to the threads of the hardware (6 and 7) and secure the outer ring of the coupling to the engine flywheel by torquing the hardware to 45 ft. lbs. (540 in. lbs. or 6,2 m. kg.).

Position the bellhousing adaptor ring (not shown) on the studs (8) against the engine bellhousing. Using a suitable lifting device, position the assembled drive and rotating assembly so the flexible portion of the coupling seats inside the outer ring attached to the engine flywheel.

NOTE

To ease installation, **lightly** lubricate the rubber portion of the coupling with a **non-petroleum based lubricant** such as vegetable oil or glycerin, or a silicon-based lubricant such as "WD40" or equivalent.

Do not use petroleum-based lubricants, or any other substance which may soften or otherwise damage the rubber.

Install the intermediate guards (25, Figure 5), and secure the mounting flange to the engine bellhousing with the previously removed hardware (6, 7 and 9).

(Figure 3)

Use a suitable hoist and sling to position the air compressor assembly (6) on the mounting flange (9, Figure 5). Slide the synchronous belt (15) over the air compressor drive sheave. Use a pry bar to raise the compressor high enough to install the spacers (14) between the compressor and the mounting flange. Secure the compressor to the mounting flange with the hardware (8, 9 and 10). Reinstall the guard (7) and secure it with the hardware (11, 12 and 13).

Seal Reassembly and Installation**(Figures 5 and 11)**

Most cleaning solvents are toxic and flammable. Use them only in a well ventilated area free from excessive heat, sparks, and flame. Read and follow all precautions printed on solvent containers.

Clean the seal cavity and shaft with a cloth soaked in fresh cleaning solvent. Inspect the stationary seat bore in the seal plate for dirt, nicks and burrs, and remove any that exist. The stationary seat bore **must** be completely clean before installing the seal.

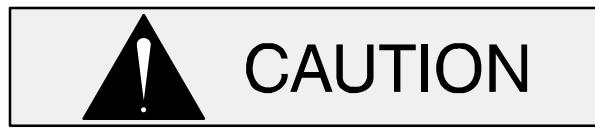

A new seal assembly should be installed **any time** the old seal is removed from the pump. Wear patterns on the finished faces cannot be realigned during reassembly. Reusing an old seal could result in premature failure.

The seal is not normally reused because wear patterns on the finished faces cannot be realigned during reassembly. This could result in premature failure. If necessary to reuse an old seal in an emergency, **carefully** wash all metallic parts in **fresh** cleaning solvent and allow to dry thoroughly.

Handle the seal parts with extreme care to prevent damage. Be careful not to contaminate precision finished faces; even fingerprints on the faces can shorten seal life. If necessary, clean the faces with a non-oil based solvent and a clean, lint-free tissue. Wipe **lightly** in a concentric pattern to avoid scratching the faces.

Inspect the seal components for wear, scoring, grooves, and other damage that might cause leakage. Clean and polish the shaft sleeve, or replace it if there are nicks or cuts on either end. If any components are worn, replace the complete seal; **never mix old and new seal parts.**

If a replacement seal is being used, remove it from the container and inspect the precision finished faces to ensure that they are free of any foreign matter.

To ease installation of the seal, lubricate the shaft sleeve O-ring and the external stationary seat O-ring with a very **small** amount of light lubricating oil. See Figure 10 for seal part identification.

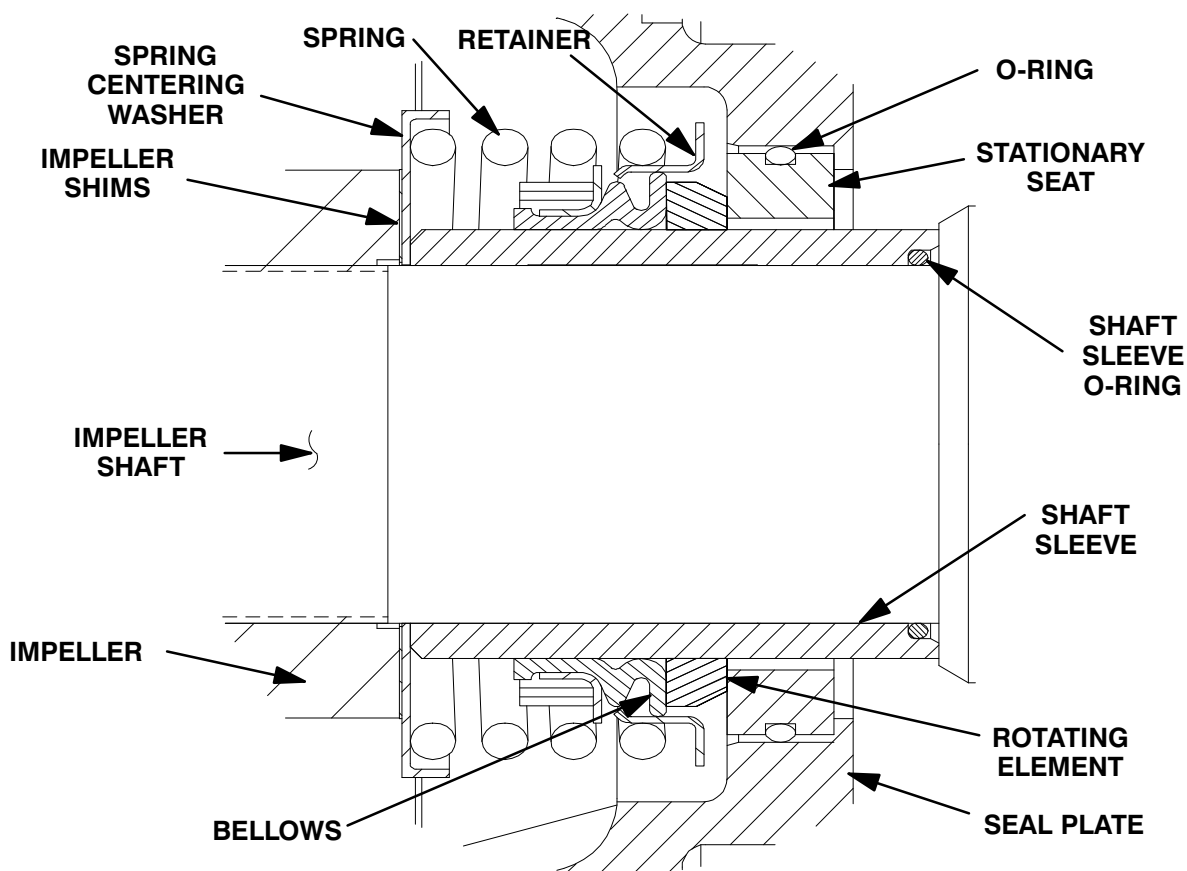

Figure 11. Seal Assembly



This seal is not designed for operation at temperatures above 160°F (71°C). Do not use at higher operating temperatures.

Lubricate the stationary seat O-ring with water or light oil. Press the stationary seat into the seal plate (20) until fully seated.

Position the seal plate over the shaft and secure it to the bearing housing (4) with the hardware (18 and 19). **Be careful** not to damage the stationary seat on the shaft threads.

Lubricate a new seal plate O-ring (35) with grease and install it in the groove in the seal plate.

To prevent damaging the shaft sleeve O-ring (27) on the shaft threads, stretch the O-ring over a piece of tubing. The I.D. of the tubing must be slightly larger than the O.D. of the shaft. To ease installation

the tubing wall should be as thin as possible. The length should be long enough to cover the threads on the end of the shaft. Slide the tube over the shaft threads, then slide the O-ring off the tube and onto the shaft. Remove the tube, and continue to slide the O-ring down the shaft until it seats against the shaft shoulder.

Lubricate the O.D. of the seal sleeve with a **small** amount of light oil. Slide the rotating subassembly (consisting of rotating element, bellows and retainer) onto the shaft sleeve (29) until the sealing face is just flush with the undercut end of the sleeve.

Slide the assembled shaft sleeve and rotating portion of the seal onto the shaft until the seal faces contact. Continue to press the sleeve onto the shaft until it is fully seated against the shaft shoulder.

Install the seal spring and centering washer. Lubricate the seal as indicated in **LUBRICATION** after the impeller is installed.

Impeller Installation And Adjustment

(Figure 5)

Inspect the impeller (1) and replace it if cracked or badly worn.



The shaft and impeller threads **must** be completely clean before reinstalling the impeller. Even the slightest amount of dirt on the threads can cause the impeller to seize to the shaft, making future removal difficult or impossible without damage to the impeller or shaft.

Install the same thickness of impeller adjusting shims (28) as previously removed and screw the impeller onto the shaft until tight.

NOTE

At the slightest sign of binding, **immediately** back the impeller off, and check the threads for dirt. **Do not** try to force the impeller onto the shaft.

A clearance of .025 to .040 inch (0,64 to 1,02 mm) between the impeller and the seal plate is necessary for maximum pump efficiency. Measure this clearance, and add or remove impeller adjusting shims as required.

Apply 'Never-Seeze' or equivalent compound to the threads of the capscrew (21). Secure the impeller to the shaft with the impeller washer (22) and capscrew. Torque the impeller capscrew to 90 ft. lbs. (12,4 m. kg.).

Pump Casing Installation

(Figure 4)

Lubricate the O-rings (6 and 16) with light grease, and install them in the grooves in the bearing housing and seal plate. Use a suitable hoist and sling to slide the pump casing (1) over the rotating assembly.

Install the same thickness of adjusting shims (14) as previously removed and secure the rotating as-

sembly to the pump casing with the hardware (12 and 13).

Wear Plate And Back Cover Plate Installation And Adjustment

(Figures 4 and 12)

If the wear plate (5) was removed for replacement, carefully center it on the back cover (17) and secure it with the hardware (3 and 4).

Lubricate the O-rings (6 and 16) with light grease and install them in the grooves in the wear plate and back cover.

Clearance between the impeller and wear plate is adjusted using four back cover nuts (21) and locking collars (18). There are 18 detents on the I.D. of each locking collar. Indexing the collars one detent on the adjusting screws represents approximately .005 inch (0,13 mm) of wear plate clearance. The recommended clearance between the wear plate and the impeller is .010 to .020 inch (0,25 to 0,50 mm).

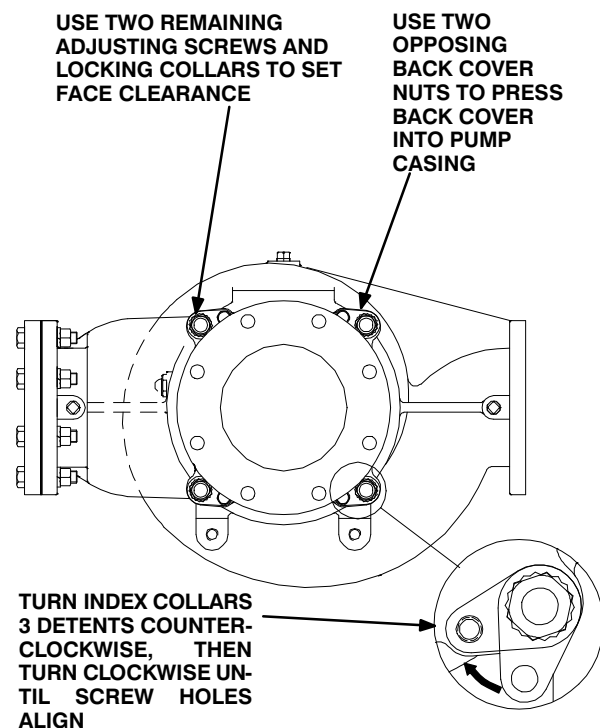

Figure 12. Installing and Adjusting Back Cover

Screw the four adjusting screws (19) into the tapped holes in the back cover plate until they are **just flush** with the machined surface on the back side of the cover plate.

Align the back cover plate over the studs (20) and slide it into the pump casing. Use two back cover nuts on diagonally opposing studs to press the back cover into the pump casing until the wear plate **just touches** the impeller when the shaft is turned by hand. **Tighten the hand nuts evenly to avoid binding.**

With the wear plate just touching the impeller, turn the two free adjusting screws until they engage the pump casing. Position the locking collars over the adjusting screws so the holes in the collars for the locking screws align approximately with the holes in the cover plate.

Loosen the back cover nuts used to press the back cover into the pump casing one full turn.

Pull the collars off the adjusting screws, index them three detents counterclockwise, and reinstall the collars on the adjusting screws. Use the collars to turn the adjusting screws clockwise until the holes in the locking collars realign with the tapped screw holes in the back cover plate. Secure the locking collars to the back cover plate with the hardware (13 and 35). Install the two remaining hand knobs snugly against the adjusting screws.

Remove the first two back cover nuts from their studs. Turn the adjusting screws clockwise until they engage the pump casing. Install the locking collars and hardware (13 and 35). Reinstall the back cover nuts.

Be sure the wear plate does not scrape against the impeller.

Over time it may be necessary to repeat the adjustment process to compensate for normal wear between the impeller and wear plate. When all of the adjustment has been used on the back cover side of the pump, an additional 0.120 inch (3 mm) of adjustment may be obtained by removing the rotating assembly adjusting shims (14).

Allow an installed pump to completely cool before draining liquid from the pump casing. Remove the back cover. Remove the rotating assembly adjusting shims, then reinstall the hardware securing the rotating assembly to the pump casing. Perform the back cover adjustment procedure described above to obtain the proper face clearance.

Discharge Check Valve Reassembly And Installation

(Figure 3)

If the discharge check valve (26) was disassembled to replace the flapper or cover O-ring, position the flapper in the valve body and check to ensure free movement.

Install the valve cover O-ring and secure the cover to the body with the previously removed hardware.

Apply a small amount of light grease to the discharge flange gasket to hold it in place and position it against the pump casing flange. Support the discharge check valve assembly using a sling and a suitable lifting device. Using the previously removed hardware, secure the discharge check valve assembly and flange gasket to the pump assembly (1).

Priming Chamber Assembly And Installation

(Figure 7)

Clean and inspect the components of the priming valve (1). Inspect the linkage and ensure the orifice button (not shown) squarely engages the valve seat. Replace the orifice button if required (see **Priming Chamber Removal and Disassembly** for orifice button removal).

If the orifice button was removed, screw the new orifice button into the linkage bar until fully seated. Align the hole in the linkage bar with the holes in the bracket and reinstall the pivot pin. Secure the pivot pin with the previously removed “e-clip”.

Adjust the orifice button seating as necessary by screwing the orifice button into or out of the linkage bar. Proper adjustment is achieved when the orifice button fully seats against the orifice before the linkage bar on the float bottoms against the threads on the orifice button. When adjustment is complete, install and tighten the lock washer and hex nut securing the orifice button.

Install the strainer (6) and priming valve gasket (4).

Lower the float into the priming chamber (5) and secure the priming valve with the previously removed hardware (2 and 3).

(Figure 6)

Install the baffle (9) and gasket (8) and use a sling and suitable lifting device to position the priming

chamber assembly on the pump casing (1, Figure 4). Secure the priming chamber assembly with the hardware (6 and 7).

Reconnect the suction piping to the hopper spool and the air discharge tubing to the priming chamber assembly.

LUBRICATION

(Figure 5)

Seal Assembly

Before starting the pump, remove the vented plug (8) and fill the seal cavity with approximately 8 quarts (7,6 liters) of SAE No. 30 non-detergent oil or to the center of the sight gauge (27). Clean and reinstall the vented plug. Maintain the oil level at the middle of the sight gauge.

Bearings

(Figure 3)

The bearing housing was fully lubricated when shipped from the factory. Check the oil level regularly through the sight gauge (23) and maintain it at the midpoint of the gauge. When lubrication is required, remove the air vent (6) and add SAE No. 30 non-detergent oil through the opening. When lubricating a dry (overhauled) intermediate, fill the bearing cavity with approximately 40 ounces (1,2 liter).

Clean and reinstall the air vent. **Do not** over-lubricate. Over-lubrication can cause the bearings to over-heat, resulting in premature bearing failure.

NOTE

The white reflector in the sight gauge must be positioned horizontally to provide proper drainage.

Under normal conditions, drain the bearing housing once each year and refill with clean oil. Change the oil more frequently if the pump is operated continuously or installed in an environment with rapid temperature change.



Monitor the condition of the bearing lubricant regularly for evidence of rust or moisture condensation. This is especially important in areas where variable hot and cold temperatures are common.

For cold weather operation, consult the factory or a lubricant supplier for the recommended grade of oil.

Engine

Consult the literature supplied with the engine, or contact your local engine representative.

**For U.S. and International Warranty Information,
Please Visit www.grpumps.com/warranty
or call:
U.S.: 419-755-1280
International: +1-419-755-1352**

**For Canadian Warranty Information,
Please Visit www.grcanada.com/warranty
or call:
519-631-2870**