



VARIOUS PATENTS APPLY

Priming Assisted Centrifugal Environmental Silent Pump w/Autostart Model PA6C60D-4045T FT4-ESP

Size 6" x 6"



Total Head		Capacity of Pump in U.S. Gallons per Minute (GPM) at Continuous Performance			
P.S.I.	Feet				
62.4	144	200	200	200	200
60.7	140	480	480	480	480
52.0	120	840	1060	1060	1060
43.3	100	965	1440	1560	1560
34.7	80	1045	1480	1810	1920
26.0	60	1100	1515	1820	2120
17.3	40	1140	1525	1820	2130
Suction Lift		25'	20'	15'	10'

PUMP SPECIFICATIONS

- Size:** 6 x 6" (152 mm x 152 mm) Flanged.
- Casing:** Ductile Iron 65-45-12.
Maximum Operating Pressure 96 psi (662 kPa).*
- Open Type, Two Vane Impeller:** Ductile Iron 65-45-12.
Handles 3" (76,2 mm) Diameter Spherical Solids.
- Impeller Shaft:** Stainless Steel 17-4 PH.
- Replaceable Wear Plate:** Ductile Iron 80-60-03.
- Bearing Housing:** Gray Iron 30.
- Seal Plate:** Gray Iron 30.
- Seal:** Mechanical, Oil-Lubricated. Silicon Carbide Rotating and Stationary Faces. Stainless Steel 316 Stationary Seat. Fluorocarbon Elastomers (DuPont Viton® or Equivalent). Stainless Steel 18-8 Cage and Spring. Maximum Temperature of Liquid Pumped, 160°F (71°C).*
- Shaft Sleeve:** Stainless Steel 17-4 PH.
- Priming Chamber:** Gray Iron 30 Housing w/Stainless Steel Float and Linkage.
- Discharge Check Valve:** Ductile Iron Housing with Welded Nickel Seat and Buna-N Flapper.
- Radial/Thrust Bearings:** Open Double Row Ball.
- Bearing Lubrication:** SAE 30 Non-Detergent Oil.
- Gaskets:** Resistant Synthetic Rubber, Buna-N, Vegetable Fiber, and Compressed Synthetic Fibers.
- O-Rings:** Buna-N. Fluorocarbon (DuPont Viton® or Equivalent).
- Hardware:** Standard Plated Steel.
- Bearing and Seal Cavity Oil Level Sight Gauges.**

*Consult Factory for Applications Exceeding Maximum Pressure and/or Temperature Indicated.

Standard Equipment: Belt-Driven Diaphragm Primer. Hoisting Bail. Sound-proof (EPA Average 75 dBA at 23 feet [7 meters] Under Load per CPB Standards) Lightweight Aluminum Enclosure - Removable for Maintenance of Pump or Engine - w/Padlockable Door Panels. Combination Skid Base w/ Fuel Tank. [Single Ball Type Float Switch](#) . [Full Feature Control Panel](#) **

Optional Equipment: Battery. Skid Base Kit. Heated Priming Chamber Kit. Suction and Discharge Quick Connect Kit. High Speed (55 MPH/89 KM/H) Single Axle Pneumatic-Tired Wheel Kit w/wo DOT-Approved Lights and Electric Brakes. [Tandem Axle Over-the-Road Trailer](#) (Meets DOT Requirements) Available w/Either Electric or Hydraulic Surge Brakes, Running Lights, Jack Stands and Safety Cables/Chains. Liquid Level Transducer.

**50 Ft. (15 m) Standard Length; Dual Switches and Alternate Cable Lengths Available From the Factory.



WARNING!
Do not use in explosive atmosphere or for pumping volatile flammable liquids.

ENGINE SPECIFICATIONS

- Model:** John Deere 4045T.
- EPA Tier:** Final Tier 4.
- Type:** Turbocharged Four Cylinder, Diesel Engine.
- Displacement:** 276 Cu. In. (4,5 liters).
- Lubrication:** Forced Circulation.
- Air Cleaner:** Dry Type.
- Fuel Tank:** 102 U.S. Gals. (386 liters).
- Full Load Operating Time:** 27.2 Hrs.
- Starter:** 12V Electric.

Standard Features: Weather Cap, DOC/DPF Exhaust After-Treatment System.

Engine Control Features: Padlockable Box with Throttle Control, Tachometer, Coolant Temperature, Oil Pressure, Voltage and Overstart Indicators/Shutdowns. Manual/Stop/Auto Keyswitch. Audible Startup Warning Delay. Fuel Level Display/Alarm/Shutdown Electronic Fuel Level Sensor.

JOHN DEERE PUBLISHED PERFORMANCE:
Maximum Net Continuous BHP
74 (55 kW) @ 2400 RPM



GORMAN-RUPP PUMPS

www.grpumps.com

Specifications Subject to Change Without Notice

Printed in U.S.A.

Specification Data

SECTION 42, PAGE 1115

APPROXIMATE
DIMENSIONS and WEIGHTS

NET WEIGHT:
SHIPPING WEIGHT:
EXPORT CRATE SIZE:

SKID BASE

4360 LBS. (1997,7 KG.)
4680 LBS. (2122, KG.)
332 CU. FT. (9,4 CU. M.)

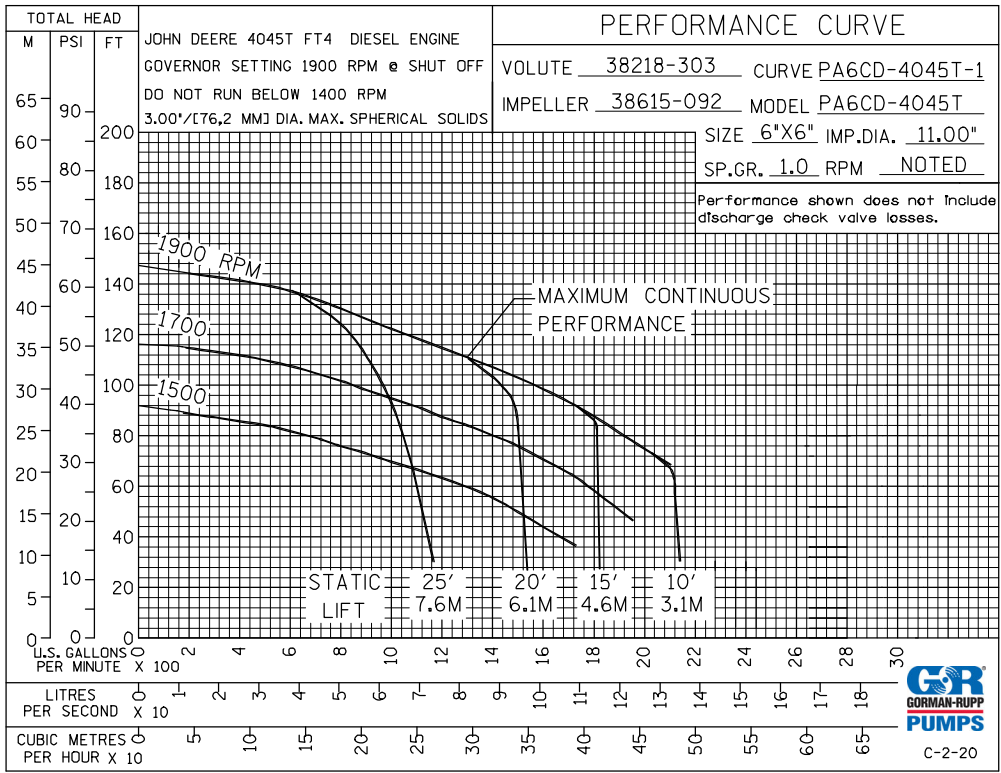
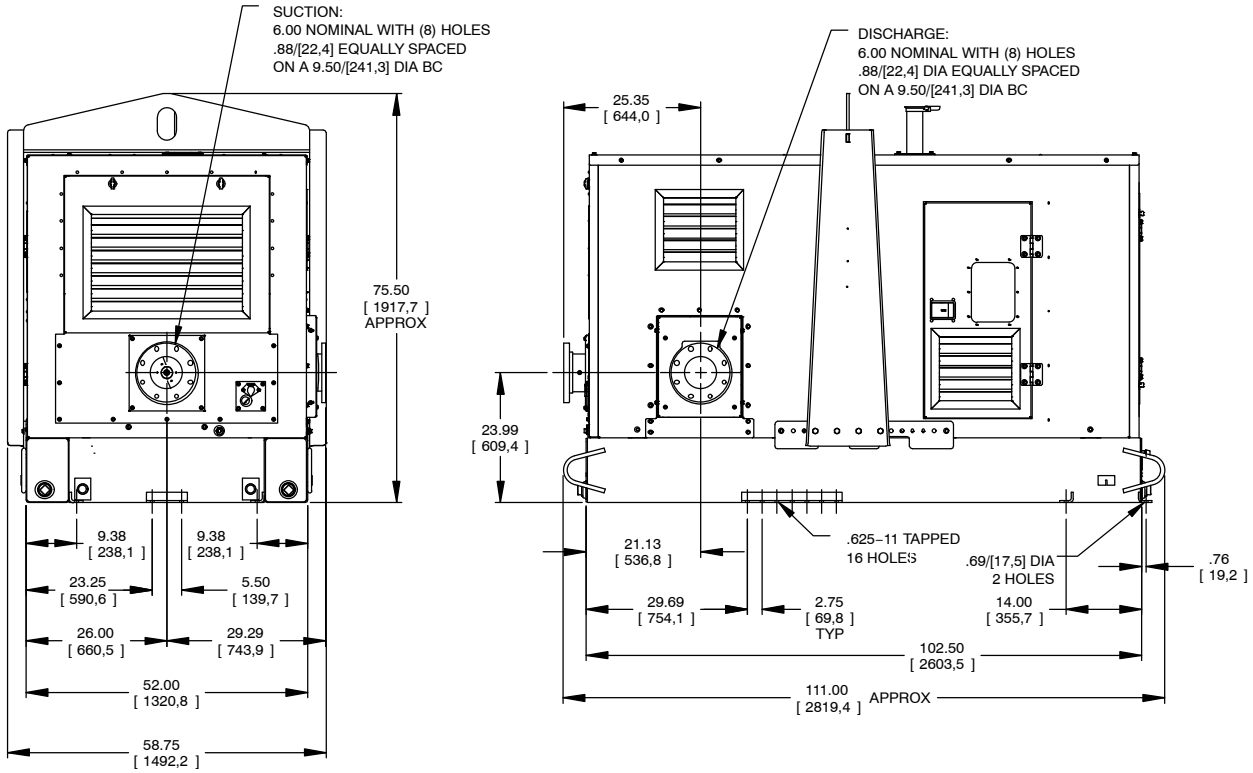

58.



GORMAN-RUPP PUMPS

www.grpumps.com

Specifications Subject to Change Without Notice

Printed in U.S.A.