



# Self Priming Centrifugal Pump

## Model 13E52-GX390

### Size 3" x 3"



Total Head		Capacity of Pump in U.S. Gallons per Minute (GPM) at Continuous Performance				
P.S.I.	Feet	75	75	75	75	75
42.0	97	75	75	75	75	75
38.1	90	137	137	137	137	137
34.7	80	197	253	253	253	253
30.3	70	205	275	225	340	340
26.0	60	210	280	340	400	410
21.7	50	210	283	345	413	450
17.3	40	213	284	350	417	465
13.0	30	216	286	353	421	475
<b>Suction Lift</b>		<b>25'</b>	<b>20'</b>	<b>15'</b>	<b>10'</b>	<b>5'</b>



#### PUMP SPECIFICATIONS

**Size:** 3" x 3" (76 mm x 76 mm) NPT - Female.

**Casing:** Gray Iron 30.

Maximum Operating Pressure 68 psi (469 kPa).\*

**Semi-Open Type, Two Vane Impeller:** Ductile Iron 65-45-12.  
Handles 2" (50,8 mm) Diameter Spherical Solids.

**Replaceable Wear Plate:** Standard Carbon Steel ASTM A36.

**Removable Cover Plate:** Gray Iron 30; 12 lbs. (5,4 kg).

**Intermediate Bracket:** Gray Iron 30.

**Shaft Sleeve:** Alloy Steel 4130.

**Seal:** Type 31, Mechanical, Self-Lubricated. Silicon Carbide Rotating and Stationary Faces. Fluorocarbon Elastomers (DuPont Viton® or Equivalent). Stainless Steel 18-8 Cage and Spring. Maximum Temperature of Liquid Pumped 160°F (71°C).\*

**Flap Valve:** Buna-N w/Nylon Reinforcement; Gray Iron 30.

**Flange:** Gray Iron 30.

**Gaskets:** Cork.

**Hardware:** Standard Plated Steel.

**Roll Cage with Rubber Feet.**

**90° Discharge Elbow.**

**Strainer.**

**Optional Equipment:** Wheel Kit w/Semi-Pneumatic Tires.

*\*Consult Factory for Applications Exceeding Maximum Pressure and/or Temperature Indicated.*



#### WARNING!

Do not use in explosive atmosphere or for pumping volatile flammable liquids.

#### ENGINE SPECIFICATIONS

**Model:** Honda GX390.

**Type:** Single Cylinder, Air Cooled, Overhead Valve, Gasoline Engine.

**Displacement:** 23.7 Cu. In. (388 cc).

**Cylinder:** Aluminum Alloy.

**Air Cleaner:** Dual Element.

**Fuel Tank:** 6.9 U.S. Qts. (6,5 liter).

**Full Load Operating Time:** 1.9 Hrs.

**Starter:** Recoil.

**Ignition System:** Transistorized Magneto.

**Standard Equipment:** Muffler w/Guard. Rotary Stop Switch. Manual Throttle Control w/Top Speed Limit. Manual Choke and Fuel Valve. Oil Alert™ Shut Down. Fill/Drain Ports Each Side w/Dipstick One Side Only. Spark Plug Cover.



## GORMAN-RUPP PUMPS

www.grpumps.com

Specifications Subject to Change Without Notice

Printed in U.S.A.

# Specification Data

SECTION 45, PAGE 720

APPROXIMATE DIMENSIONS and WEIGHTS

**NET WEIGHT:** 300 LBS. (136 KG.)  
**SHIPPING WEIGHT:** 363 LBS. (165 KG.)  
**EXPORT CRATE SIZE:** 23.9 CU. FT. (0,7 CU. M.)  
**WHEEL KIT ADD 46 LBS. (21 KG.); SHIPPING CRATE (SEPARATE) 3 CU. FT. (0,1 CU. M.)**

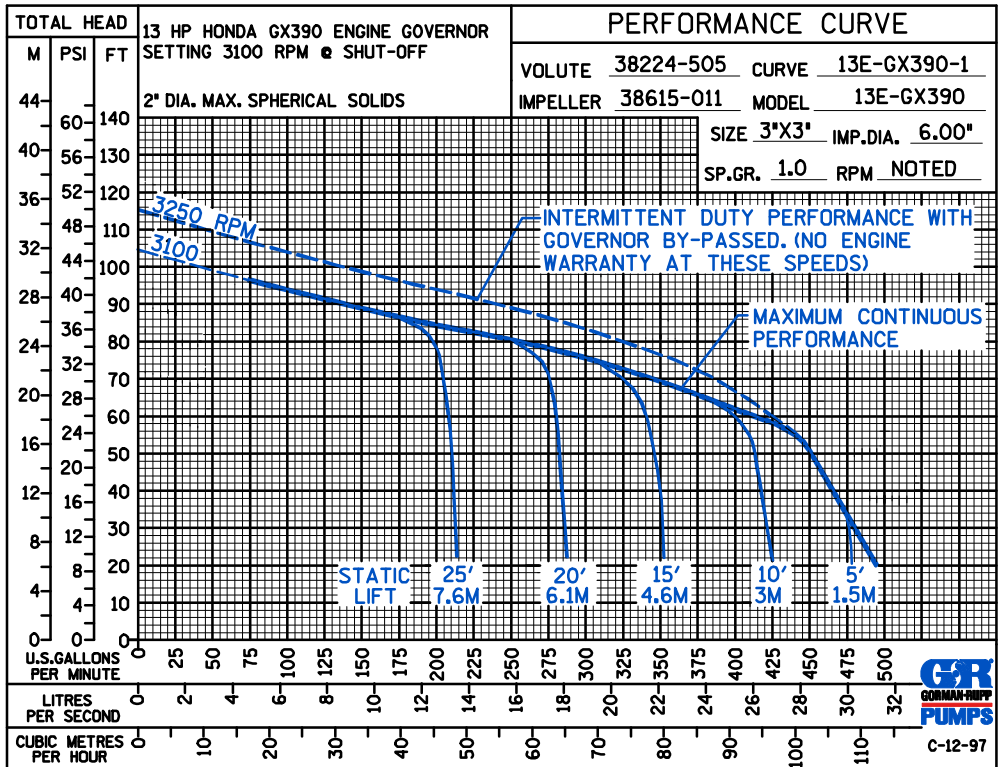
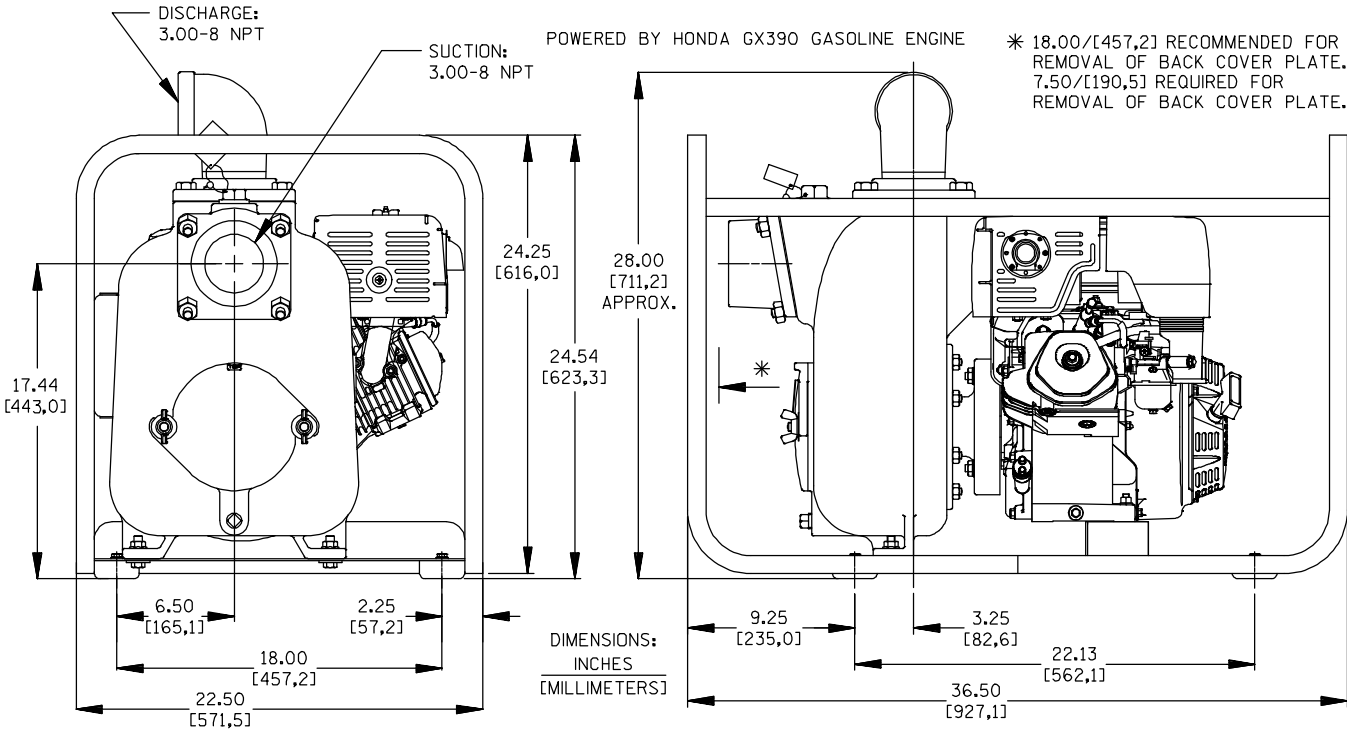

**GORMAN-RUPP PUMPS**

www.grpumps.com

Specifications Subject to Change Without Notice

Printed in U.S.A.