



# Self Priming Centrifugal Pump

Model

62 1/2D1—GX690 S/G

Size 2 1/2" x 2 1/2"



## PUMP SPECIFICATIONS

**Size:** 2 1/2" x 2 1/2" (64 mm x 64 mm) N.P.T. Female.

**Casing:** Aluminum Alloy.

Maximum Operating Pressure 250 psi. (1723 kPa).\*

**Enclosed Type, Five Vane Impeller:** Aluminum Alloy 319.

Handles 1/16" (1,6 mm) Diameter Spherical Solids.

**Replaceable Wear Ring:** Bronze Alloy 954.

**Replaceable Balance Ring:** Bronze Alloy 954.

**Intermediate Bracket:** Aluminum Alloy 319.

**Seal:** Type 21, Mechanical Self-Lubricated. Carbon Rotating Face. Silicon Carbide Stationary Face. Fluorocarbon Elastomers (DuPont Viton® or Equivalent). Stainless Steel Type 18-8 Cage and Spring. Maximum Temperature of Liquid Pumped, 180°F (82°C).\*

**Shaft Sleeve:** Stainless Steel 303.

**Discharge Valve Body:** Bronze.

**Gaskets:** Fluorocarbon (DuPont Viton® or Equivalent).

**Hardware:** Standard Plated Steel.

**Standard Equipment:** 12 VDC Electric Start, Steel Roll Frame with Battery Tray, Hand Primer, Build in Discharge Check Valve, Discharge Pressure Gauge, Suction Strainer.

**Optional Equipment:** Battery, Wheel Kit, NPT to Fire Hose Thread adapter, High Pressure Hose Kit.

*\*Consult Factory for Applications Exceeding Maximum Pressure and/or Temperature Indicated.*



## WARNING!

Do not use in explosive atmosphere or for pumping volatile flammable liquids.

## ENGINE SPECIFICATIONS

**Model:** Honda GX690.

**Type:** V-Twin, Four Cycle, Air Cooled, Overhead Valve Gasoline Engine.

**Displacement:** 42 Cu. In. (688 cc).

**Lubrication:** Forced Circulation.

**Air Cleaner:** Dry Type.

**Fuel Tank:** 15 U.S. Gal. (56,8 Liters).

**Full Load Operating Time:** 10.5 Hours.

**Starter:** 12 Volt Electric.

**Standard Equipment:** Exhaust Silencer Muffler. Hand Throttle and Stop Control.



GORMAN-RUPP PUMPS

www.grpumps.com

Specifications Subject to Change Without Notice

Printed in U.S.A.

**Specification Data**

**SECTION 60, PAGE 175**

APPROXIMATE  
DIMENSIONS and WEIGHTS

**SHIPPING WEIGHT:**  
**220 LBS. (100 KG.)**  
**WHEEL KIT ADD 25 LBS. (11.3 KG.);**  
**SHIPPING CRATE (SEPARATE) 31.5 CU. FT. (0,9 CU. M.)**

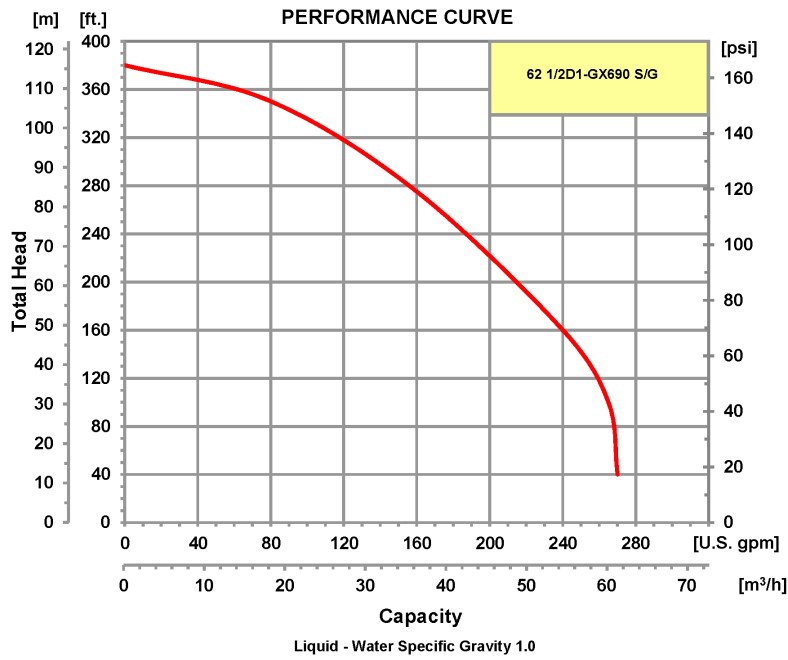
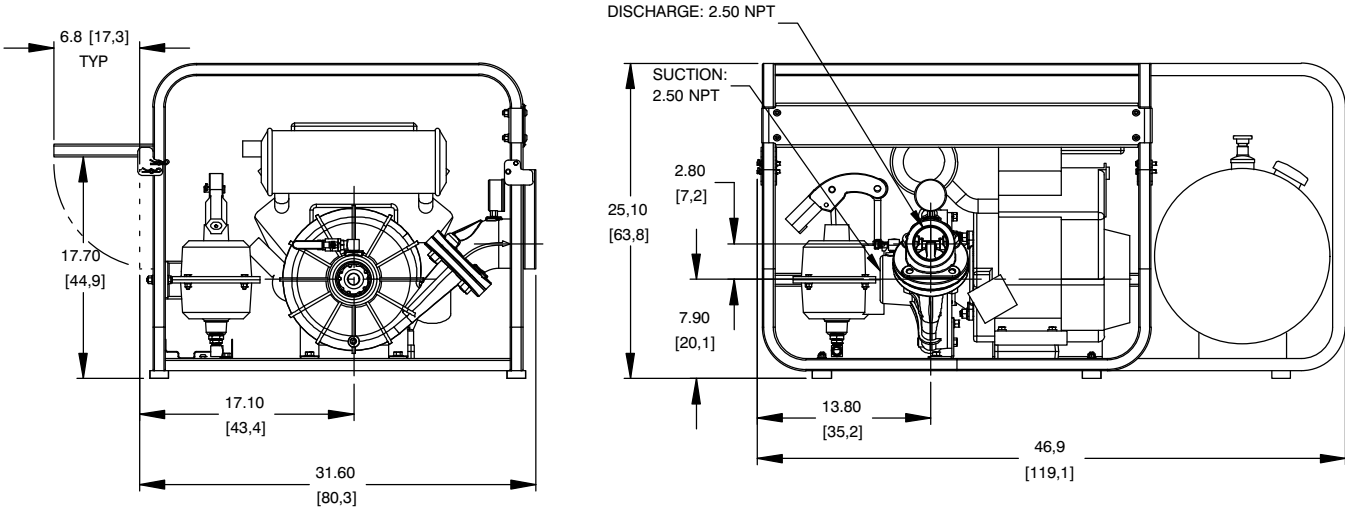

**GORMAN-RUPP PUMPS**

www.grpumps.com

Specifications Subject to Change Without Notice

Printed in U.S.A.