



Submersible Pump

Model SM6E1-X60

Size 6"



PUMP SPECIFICATIONS

MSHA PUMP APPROVAL - 2G-3971A-0.

Diffuser: G-R Hard Iron.

Maximum Operating Pressure 110 psi (758 kPa).*

Impeller: G-R Hard Iron.

Suction Head: Gray Iron 30.

Seal Plate: G-R Hard Iron.

Motor Housing: Aluminum Alloy 356-T6.

Wear Ring: Copper Alloy C83600.

Motor Shaft: Stainless Steel Type 17-4 PH.

Bearings: Upper, Two Synthetic Seals, Single Row Ball Bearing.
Lower, Two Shields, Double Row Ball Bearing.

Discharge Flange: Gray Iron 30.

Gaskets: Cork with Nitrile Binder (NC710).

O-Rings: Buna-N.

Wetted Hardware: Standard Plated Steel and Stainless Steel.

Strainer: Urethane Coated Steel; 48% Open Area,
0.50" (12.7 mm) Diameter Openings.

Base Plate: Aluminum Alloy No. 356-T6.

Hoisting Bail: Urethane Coated Steel.

Standard Equipment

NEMA Type 10 Explosion Proof Control Box Provides On-Off,
Circuit Breaker and Motor Overload Protection.

MSHA Certification No. X/P-3026-1.

Staging Adaptor.

Optional Equipment

MSHA-Certified Automatic Control Box, [Single Ball Type Float Switch](#) **

**Cable Lengths From 50 to 400 Feet Available.

MOTOR/CABLE SPECIFICATIONS

Motor: Air Filled Enclosure ^{w/}Thermal Overload Protection;
60 H.P.; 3450 R.P.M. Three Phase: 460/575 Volt, 60 Hz,
66/52.8 Full Load AMPS, 48 kW (Max.)

MSHA Certification No. X/P-3689-0.

Power Cable: 9 Wire; Type SPC; (3) 6 AWG. Power Conductors,
(1) 6 AWG. Ground Conductor, (4) 14 AWG. Control Conductors and
(1) 8 AWG. Ground Check. Nominal Length 50 Feet (15 m) Standard.
(Specify Alternate Length at Time of Order.) ***

*** Circuit Breaker Amp Rating and Maximum Combined Length of Motor and
Trailing Cables May Apply (Consult Factory for Details).

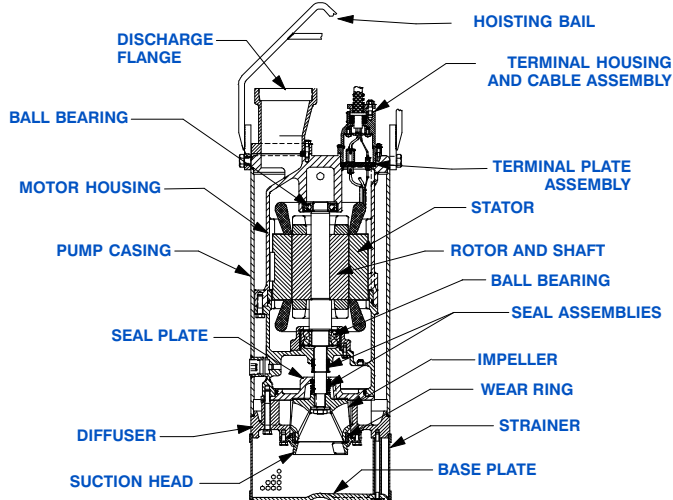
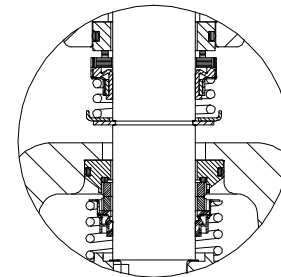

SEAL SPECIFICATIONS

Tandem, Oil Lubricated.

Upper Seal: Type 21, Mechanical. Carbon Rotating Face.
Ni-Resist Stationary Face. Fluorocarbon Elastomers
(DuPont Viton® or Equivalent). Stainless Steel 18-8
Cage and Spring.

Lower Seal: Type 2, Mechanical. Silicon Carbide Rotating
Face and Tungsten Titanium Carbide Stationary Face.
Stainless Steel 316, Stationary Seat. Fluorocarbon Elastomers
(DuPont Viton® or Equivalent). Stainless Steel 18-8
Cage and Spring.

Maximum Temperature of Liquid Pumped, 122°F (50°C).*

* Consult Factory for Applications Exceeding Maximum
Pressure and/or Temperature Indicated.



GORMAN-RUPP PUMPS

www.grpumps.com

Specifications Subject to Change Without Notice

Printed in U.S.A.

Specification Data

APPROXIMATE
DIMENSIONS and WEIGHTS

PUMP & CABLE NET WEIGHT:
CONTROL BOX; NET WEIGHTS:
GROSS SHIPPING WEIGHT:
EXPORT CRATE:

828 LBS. [376 KG.]
35 LBS. [16 KG.]
938 LBS. [426 KG.]
15.0 CU. FT. [42 CU. M.]

SECTION 132, PAGE 1350

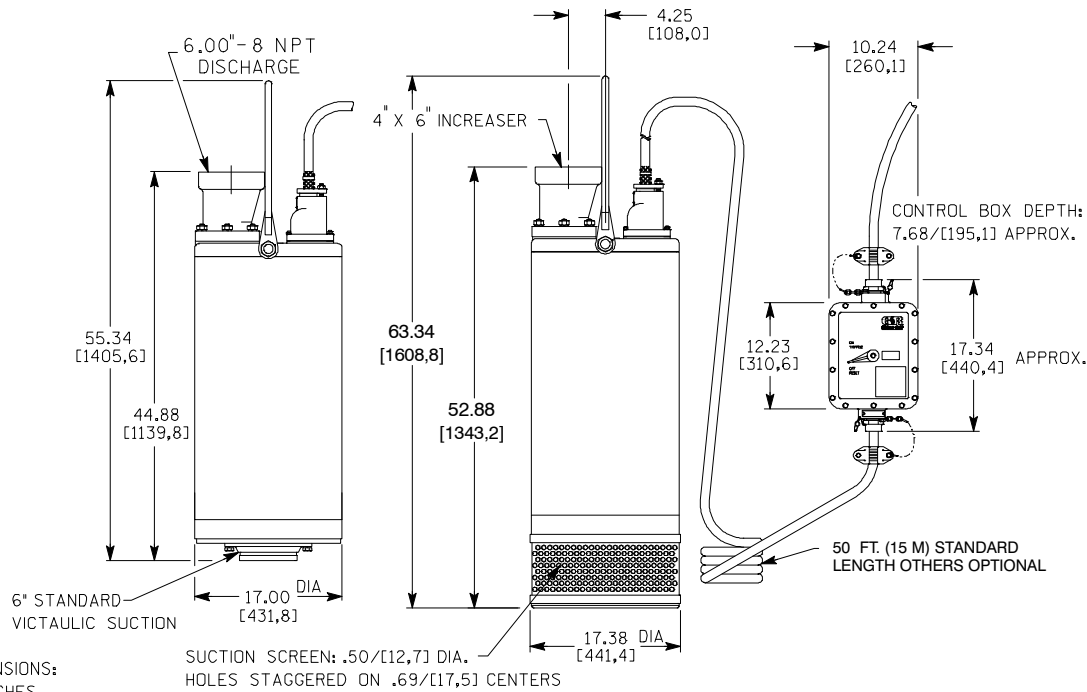

Victaulic is a Registered Trademark of Victaulic Company of America.

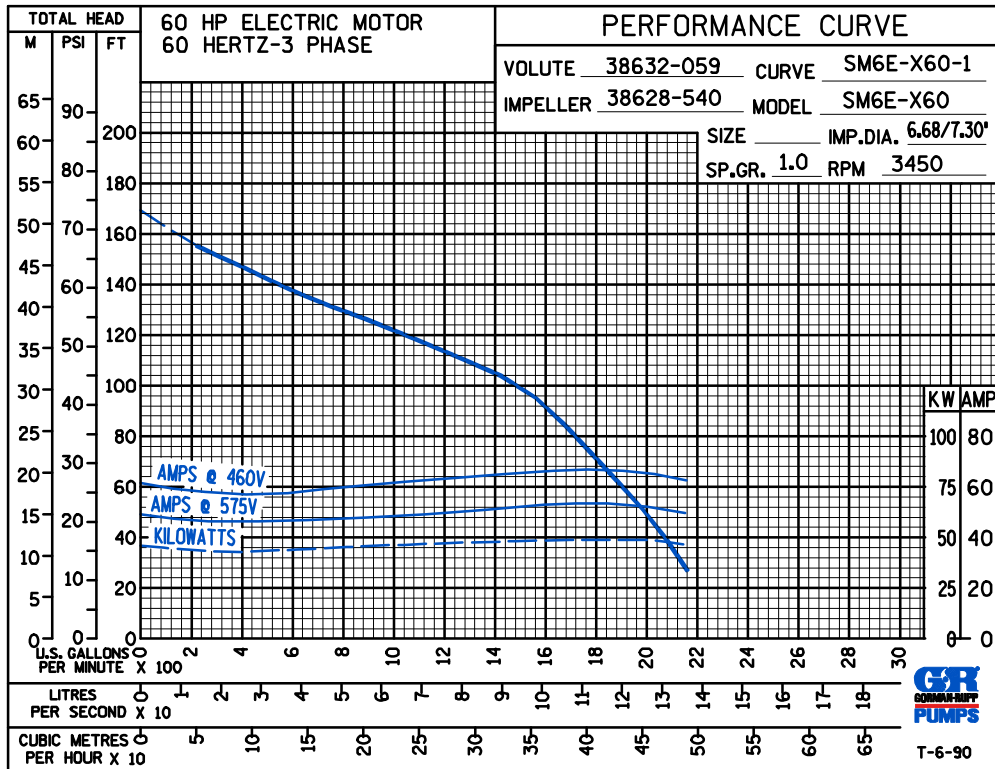

GORMAN-RUPP PUMPS

www.grpumps.com

Specifications Subject to Change Without Notice

Printed in U.S.A.