

**MEDIUM DUTY STANDARD;
 D, G, J, N & R SIZE
 ROTARY GEAR PUMP**

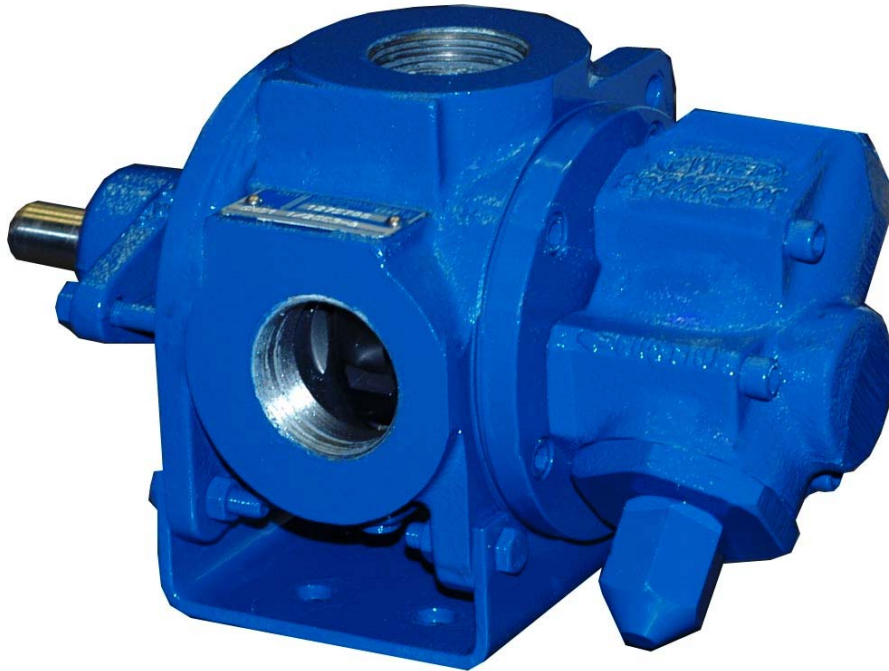

The GMS series is designed for applications in the operating ranges noted below. These units are available with head and backhead jackets (R size only) for temperature control, carbon graphite bushings for low viscosity liquids, silicon carbide bushings for wear resistance, and carbide, positive drive or packing seals for viscous sealing.

For continuous service, or for handling more viscous liquids, see the heavy duty GHS section.

For belt driven applications, select an extended shaft option and consult factory for availability of drive assembly. A pedestal bearing is required for belt driven applications.

FEATURES

- 150 PSI CAPABILITY
- SELF-CONTAINED, NO EXTERNAL BEARING REQUIRED (UNLESS BELT DRIVEN)
- HIGH STRENGTH, COMPUTER PROFILED GEARING FOR QUIET OPERATION
- THRUST CONTROLLED PUMP ELEMENTS
- EXCEPTIONAL SEAL VERSATILITY

OPERATING RANGE

- CAPACITY (GPM) : (3 TO 265)
 [LPM] : [11 TO 930]
- PRESSURE (PSI) : (0 TO 150)
 [BAR] : [0 TO 10.3]
- VISCOSITY (SSU) : (28 TO 250,000)
 [cSt] : [1 TO 55,000]
- TEMPERATURE (F) : (-60° TO 450°)
 [C] : [-51° TO 230°]

APPLICATIONS

- ★ BOOSTER SERVICE
- ★ CIRCULATING
- ★ FILTERING
- ★ LUBRICATING
- ★ TRANSFERRING

EXT.	ROTOR & IDLER	HOUSING PORTS	BUSHINGS	IDLER PIN	SHAFT	SHAFT SEALING		ROT.	INTERNAL RELIEF VALVE	
						MECH. SEAL ●	PACKING ■		MATERIAL	SETTING
CAST IRON	HIGH STRENGTH IRON	90° TAPPED	BRONZE	HARDENED STEEL		FLUORO ^① CARBON, NI-RESIST	PTFE, ^② GRAPHITE	C.W.	DUCTILE IRON	75 PSI [5 BAR]

Standard Models

G M S 1 DC 3 - B
 GEAR DUTY DESIGN PORT SIZE HYDRAULIC SEAL STYLE

MODEL NUMBER	NOM. CAPACITY - SPEED				MAXIMUM				SHIPPING DATA	
	MAXIMUM		ALTERNATIVE		DIFFERENTIAL PRESSURE-PSI [BAR]			TEMP.	Weight	Volume
	GPM	RPM	GPM	RPM	BELOW	38 TO	100 TO	°F	LBS	CU. FT.
	[LPM]	60 Hz [50 Hz]	[LPM]	60 Hz [50 Hz]	38 SSU [4 cSt]	100 SSU [21 cSt]	250,000 SSU [55,000 cSt]	[°C]	[KG]	FT.
GMS 1DC 3-B ● GMS 1DC 4-B ■	9 [28]		6 [19]						19 [8,6]	0.6
GMS 1DE 3-B ● GMS 1DE 4-B ■	11 [35]		7 [22]						19 [8,6]	0.6
GMS 1-1/2 GC 3-B ● GMS 1-1/2 GC 4-B ■	16 [50]		10 [32]						32 [14,5]	2.9
GMS 2 GC 3-B ● GMS 2 GC 4-B ■									32 [14,5]	2.9
GMS 1-1/2 GF 3-B ● GMS 1-1/2 GF 4-B ■	23 [73]	1750 [1460]	15 [47]	1150 [960]				400 [205]	32 [14,5]	2.9
GMS 2 GF 3-B ● GMS 2 GF 4-B ■					50 [3]	75 [5]	150 [10.3]		32 [14,5]	2.9
GMS 1-1/2 GH 3-B ● GMS 1-1/2 GH 4-B ■	31 [98]		20 [63]						32 [14,5]	2.9
GMS 2 GH 3-B ● GMS 2 GH 4-B ■								450 [230]	32 [14,5]	2.9
GMS 1-1/2 GJ 3-B ● GMS 1-1/2 GJ 4-B ■	38 [120]		25 [79]						32 [14,5]	2.9
GMS 2 GJ 3-B ● GMS 2 GJ 4-B ■									32 [14,5]	2.9
GMS 2 JG 3-B ● GMS 2 JG 4-B ■									83 [37,6]	2.9
GMS 2-1/2 JG 3-B ● GMS 2-1/2 JG 4-B ■	33 [126]	960 [960]	30 [95]	870 [725]					83 [37,6]	2.9
GMS 3 JG 3-B ● GMS 3 JG 4-B ■									83 [37,6]	2.9
STANDARD MODELS CONT.										

NOTE: RECOMMENDED PORT SIZES ARE SHOWN IN **BOLDFACE**. EXAMPLE: **GMS 2GJ3-B**

● MECHANICAL SEAL

■ PACKING/LIPSEAL

① DUPONT VITON® OR EQUIVALENT

② DUPONT TEFLON® OR EQUIVALENT

THE GORMAN-RUPP COMPANY • MANSFIELD, OHIO

GORMAN-RUPP OF CANADA LIMITED • ST. THOMAS, ONTARIO, CANADA

Standard Models Cont'd

MODEL NUMBER	NOM. CAPACITY - SPEED				MAXIMUM				SHIPPING DATA	
	MAXIMUM		ALTERNATIVE		DIFFERENTIAL PRESSURE-PSI [BAR]			TEMP.	Weight	Volume
	GPM [LPM]	RPM 60 Hz [50 Hz]	GPM [LPM]	RPM 60 Hz [50 Hz]	BELOW 38 SSU [4 cSt]	38 TO 100 SSU [21 cSt]	100 TO 250,000 SSU [55,000 cSt]	°F [°C]		
GMS 2 JJ 3-B ● GMS 2 JJ 4-B ■	47 [177]	960 [960]	42 [133]	870 [725]	50 [3]	75 [5]	150 [10.3]	● 400 [205]	83	2.9
GMS 2-1/2 JJ 3-B ● GMS 2-1/2 JJ 4-B ■									83 [37,6]	2.9
GMS 3 JJ 3-B ● GMS 3 JJ 4-B ■									83 [37,6]	2.9
GMS 2 JL 3-B ● GMS 2 JL 4-B ■	64 [243]	960 [960]	58 [183]	870 [725]	50 [3]	75 [5]	150 [10.3]	● 400 [205]	83	2.9
GMS 2-1/2 JL 3-B ● GMS 2-1/2 JL 4-B ■									83 [37,6]	2.9
GMS 3 JL 3-B ● GMS 3 JL 4-B ■									83 [37,6]	2.9
GMS 2 JP 3-B ● GMS 2 JP 4-B ■	89 [338]	960 [960]	81 [256]	870 [725]	50 [3]	75 [5]	150 [10.3]	● 400 [205]	83	2.9
GMS 2-1/2 JP 3-B ● GMS 2-1/2 JP 4-B ■									83 [37,6]	2.9
GMS 3 JP 3-B ● GMS 3 JP 4-B ■									83 [37,6]	2.9
GMS 1-1/2 NK 3-B ● GMS 1-1/2 NK 4-B ■	90 [283]	960 [960]	60 [189]	870 [725]	50 [3]	75 [5]	150 [10.3]	■ 450 [230]	109	2.9
GMS 2 NK 3-B ● GMS 2 NK 4-B ■									109 [49]	2.9
GMS 2-1/2 NK 3-B ● GMS 2-1/2 NK 4-B ■									109 [49]	2.9
GMS 3 NK 3-B ● GMS 3 NK 4-B ■	120 [378]	960 [960]	80 [252]	870 [725]	50 [3]	75 [5]	150 [10.3]	■ 450 [230]	109	2.9
GMS 2 NM 3-B ● GMS 2 NM 4-B ■									109 [49]	2.9
GMS 2-1/2 NM 3-B ● GMS 2-1/2 NM 4-B ■									109 [49]	2.9
GMS 3 NM 3-B ● GMS 3 NM 4-B ■	150 [473]	960 [960]	99 [312]	870 [725]	50 [3]	75 [5]	150 [10.3]	■ 450 [230]	109	2.9
GMS 2 NP 3-B ● GMS 2 NP 4-B ■									109 [49]	2.9
GMS 2-1/2 NP 3-B ● GMS 2-1/2 NP 4-B ■									109 [49]	2.9
GMS 3 NP 3-B ● GMS 3 NP 4-B ■									109	2.9

STANDARD MODELS CONT.

- MECHANICAL SEAL
- PACKING/LIPSEAL

NOTE: RECOMMENDED PORT SIZES ARE SHOWN IN **BOLDFACE**. EXAMPLE: **GMS 2GJ 3-B**

THE GORMAN-RUPP COMPANY • MANSFIELD, OHIO
 GORMAN-RUPP OF CANADA LIMITED • ST. THOMAS, ONTARIO, CANADA

MODEL NUMBER	NOM. CAPACITY - SPEED				MAXIMUM				SHIPPING DATA							
	MAXIMUM		ALTERNATIVE		DIFFERENTIAL PRESSURE - PSI [BAR]			TEMP.	Weight LBS [KG]	Volume CU. FT.						
	GPM [LPM]	RPM 60 Hz [50 Hz]	GPM [LPM]	RPM 60 Hz [50 Hz]	BELOW 38 SSU [4 cSt]	38 TO 100 SSU [21 cSt]	100 TO 250,000 SSU [55,000 cSt]	°F [°C]								
GMS 2 RM 3-B ● GMS 2 RM 4-B ■	153 [542]	640 [600]	115 [362]	480 [400]				● 400 [205]	233 [106]	10.7						
GMS 2-1/2 RM 3-B ● † GMS 2-1/2 RM 4-B ■ †									233 [106]	10.7						
GMS 3 RM 3-B ● † GMS 3 RM 4-B ■ †									233 [106]	10.7						
GMS 4 RM 3-B ● † GMS 4 RM 4-B ■ †									233 [106]	10.7						
GMS 2-1/2 RP 3-B ● † GMS 2-1/2 RP 4-B ■ †									233 [106]	10.7						
GMS 3 RP 3-B ● † GMS 3 RP 4-B ■ †	190 [678]	640 [600]	143 [451]		50 [3]	75 [5]	150 [10.3]	● 400 [205]	233 [106]	10.7						
GMS 4 RP 3-B ● † GMS 4 RP 4-B ■ †	233 [106]								10.7							
GMS 2-1/2 RR 3-B ● † GMS 2-1/2 RR 4-B ■ †	228 [804]								170 [536]					■ 450 [230]	233 [106]	10.7
GMS 3 RR 3-B ● † GMS 3 RR 4-B ■ †															233 [106]	10.7
GMS 4 RR 3-B ● † GMS 4 RR 4-B ■ †															233 [106]	10.7
GMS 3 RS 3-B ● † GMS 3 RS 4-B ■ †	265 [930]	196 [618]						233 [106]	10.7							
GMS 4 RS 3-B ● † GMS 4 RS 4-B ■ †								233 [106]	10.7							

NOTE: RECOMMENDED SIZES ARE SHOWN IN **BOLDFACE**. EXAMPLE: **GMS 2GJ 3-B**

† PORTS ARE COMPATIBLE WITH 125# ANSI CAST IRON FLANGES. ALL OTHER PORTS ARE TAPPED NPT FOR ANSI PIPE. OPTIONAL [DIN] FLANGES OR TAPPED [BSP] PORTS AVAILABLE FOR EXPORT MARKET.

THE GORMAN-RUPP COMPANY • MANSFIELD, OHIO
GORMAN-RUPP OF CANADA LIMITED • ST. THOMAS, ONTARIO, CANADA

Basic Pump Dimensions

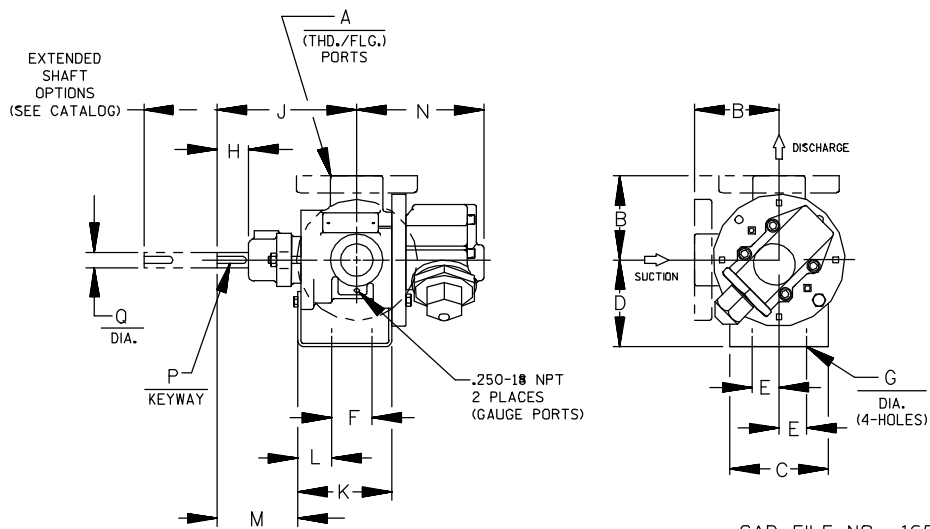

CAD FILE NO.: 16530

MODEL NUMBERS	PUMP DIMENSIONS - INCHES [MILLIMETERS]															
	A	B	C	D	E	F	G	H	J	K	L	M	N	P	Q	
GMS D	1"	2.50* [64]	4.00 [102]	3.50* [89]	1.62 [41]	1.62 [41]	.41 [10]	1.44 [36]	5.81 [148]	3.24 [82]	.89 [23]	3.99 [101]	4.97 [126]	.19 [5] x 1.00 [25]	.62 [16]	
		2.75† [70]		4.50 [114]												5.25 [133]
		3.19 [81]														
		4.00† [102]														
GMS G	1-1/2"	3.50* [89]	4.88 [124]	3.50* [89]	1.62 [41]	1.62 [41]	.41 [10]	1.64 [42]	5.96 [151]	3.85 [98]	.76 [19]	4.14 [105]	5.70 [145]	.19 [5] x 1.25 [32]	.75 [19]	
		3.75† [95]		4.50 [114]												5.25 [133]
	2"	4.00 [102]	6.25 [159]													
		4.00† [102]														
GMS J	2"	4.50* [114]	6.88 [175]	5.25* [133]	2.88 [73]	3.00 [76]	.44 [11]	2.50 [64]	9.91 [252]	5.71 [145]	1.18 [30]	7.31 [186]	8.50 [216]	.25 [6] x 2.00 [51]	1.00 [25]	
		5.00† [127]		6.25 [159]												7.00 [178]
	6.00† [152]	7.00 [178]		8.00 [203]												
	6.31† [160]	8.00 [203]														
GMS N	1-1/2"	5.12* [130]	8.00 [203]	4.50 [114]	2.88 [73]	4.25 [108]	.44 [11]	2.50 [64]	9.20 [234]	6.42 [163]	1.12 [28]	6.12 [155]	7.59 [193]	.25 [6] x 2.00 [51]	1.25 [32]	
				5.25* [133]												6.25 [159]
	7.19† [183]			7.00 [178]												8.00 [203]
				8.00 [203]												
GMS R	2"	8.50* [216]	10.25 [260]	7.00* [178]	3.75 [95]	5.75 [146]	.53 [13]	3.03 [77]	12.50 [318]	8.43 [214]	1.38 [35]	8.35 [212]	11.31 [287]	.38 [10] x 2.25 [57]	1.50 [38]	
				7.19† [183]												7.00* [178]

* STANDARD DIMENSION

† 180° HOUSING

‡ PORTS ARE COMPATIBLE WITH 125* OR 250* ANSICAST IRON FLANGES. ALL OTHER PORTS ARE TAPPED NPT FOR ANSIPPIPE. OPTIONAL (DIN) FLANGES OR TAPPED (BSP) PORTS AVAILABLE FOR EXPORT MARKET.

THE GORMAN-RUPP COMPANY • MANSFIELD, OHIO
GORMAN-RUPP OF CANADA LIMITED • ST. THOMAS, ONTARIO, CANADA



DIRECT FLEX DRIVE OPTION DIMENSIONS

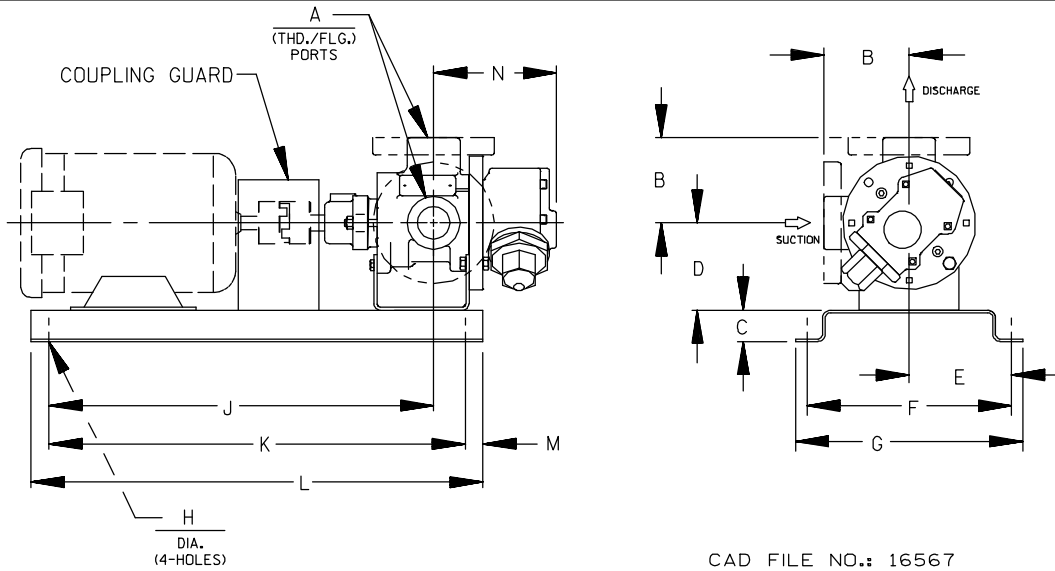

CAD FILE NO.: 16567

PUMP MODEL	PUMP DIMENSIONS - INCHES[MILLIMETERS]														
	A	B	MOTOR FRAME	C	D	E	F	G	H	J	K	L	M	N	
GMS D	1"	2.50*	56 (H)	2.00	3.50*	4.44	8.88	10.14	.56	20.04	19.25	25.25	3.00	4.97	
		[64]	143T/145T	[51]	[89]	[113]	[228]	[258]		[509]	[489]	[841]	[78]		
		2.75 †	182T/184T	4.00	4.50	7.75	15.50	17.50		26.41	23.50	33.50	5.00		[126]
		[70]	213T/215T	[102]	[114]	[197]	[394]	[445]		[671]	[597]	[851]	[127]		
GMS G	1- 1/2"	3.50*	56 (H)	2.00	3.50*	4.44	8.88	10.14	.56	20.20	19.25	25.25	3.00	5.71	
		[89]	143T/145T	[51]	[89]	[113]	[228]	[258]		[513]	[489]	[841]	[76]		
	2"	3.75 †	182T/184T	4.00	4.50	7.75	15.50	17.50	.56	26.57	23.50	33.50	5.00	[145]	
		[95]	213T/215T	[102]	[114]	[197]	[394]	[445]		[675]	[597]	[851]	[127]		
GMS J	2"	4.00 †	182T/184T	4.00	4.50	9.50	19.00	21.00	.69	36.16	35.50	45.50	5.00	8.49	
		[102]	213T/215T		[114]										[133]
	2- 1/2"	4.00 †	254T/256T	5.25*	6.25	9.50	19.00	21.00	.69	36.16	35.50	45.50	5.00	[216]	
		[102]	284T/286T	[133]	[159]	[241]	[483]	[533]	[18]	[918]	[902]	[1156]	[127]		
GMS N	1- 1/2"	4.50*	182T/184T	4.00	4.50	9.50	19.00	21.00	.69	35.44	35.50	45.50	5.00	7.59	
		[114]	213T/215T		[114]										[133]
	2"	5.00 †	254T/256T	5.25*	6.25	9.50	19.00	21.00	.69	35.44	35.50	45.50	5.00	[193]	
		[127]	284T/286T	[133]	[159]	[241]	[483]	[533]	[18]	[900]	[902]	[1158]	[127]		
2- 1/2"	6.00 †	324T/326T	8.00	7.00	9.50	19.00	21.00	.69	35.44	35.50	45.50	5.00	8.70		
	[152]		[203]	[178]	[241]	[483]	[533]	[18]	[900]	[902]	[1158]	[127]	*		
3"	6.31 †			8.00	7.00	9.50	19.00	21.00	.69	35.44	35.50	45.50	5.00	8.70	
	[160]			[203]	[178]	[241]	[483]	[533]	[18]	[900]	[902]	[1158]	[127]	*	

* STANDARD DIMENSION

† 180° HOUSING

┆ PORTS ARE COMPATIBLE WITH 125# OR 250# ANSICAST IRON FLANGES. ALL OTHER PORTS ARE TAPPED NPT FOR ANSIPPIPE. OPTIONAL (DIN) FLANGES OR TAPPED (BSP) PORTS AVAILABLE FOR EXPORT MARKET.

DIRECT FLEX DRIVE OPTIONS

Drive Assembly Number Includes Base, Coupling & Guard, But **Not** the Motor

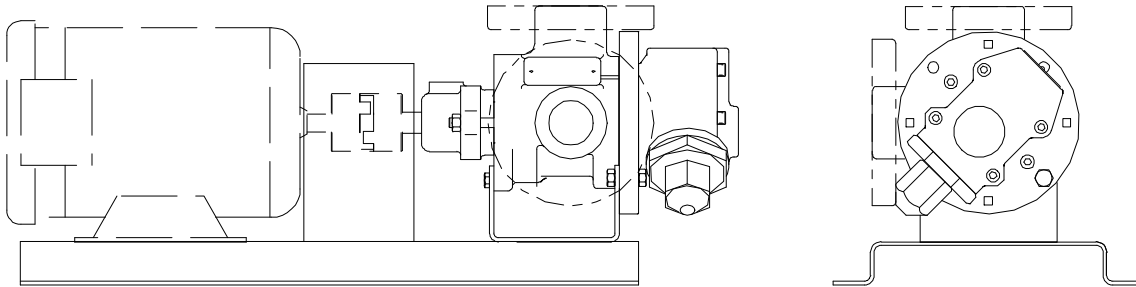

CAD FILE NO.: 16567

PUMP MODEL NUMBER	60 HZ. RPM	FRAME	MTG. FT. OPTION REQ.	DRIVE ASSY NO.
GMS D	1750 1150 850	56/56H	STD	90251-082
		143T/145T	STD	90251-084
		182T/184T	80F	90251-090
		213T/215T	80J	90251-094
GMS G	1750 1150 850	56/56H	STD	90251-160
		143T/145T	STD	90251-162
		184	80F	90221-156
		182T/184T	80F	90251-168
		213T/215T	80J	90251-176
GMS J	850	254T	80P	90251-180
		182T/184T	80F	90251-310
		213T/215T	STD	90251-318
		254T/256T	80P	90251-330
GMS N	850	284T/286T	80S	90251-338
		254T/256T	80P	90251-394
		284T/286T	80S	90251-402
		324T/326T	80V	90251-410

NOTE: CONSULT FACTORY FOR OPTIONS NOT SHOWN.



GRR REDUCER C-FLANGE FLEX DRIVE OPTION DIMENSIONS (56C - 215TC Frame Size Range)

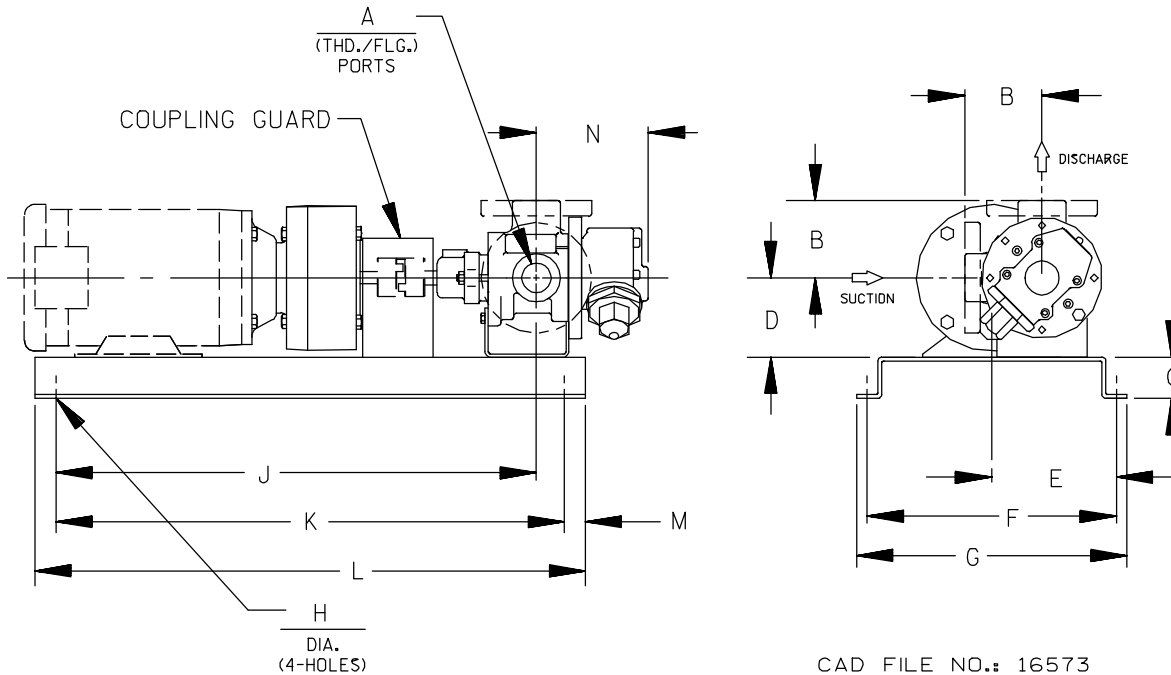

CAD FILE NO.: 16573

PUMP MODEL	PUMP DIMENSIONS															
	A	B	MOTOR FRAME	C	D	E	F	G	H	J	K	L	M	N		
GMS D	1"	2.50 * [64]	56C	2.00 [51]	3.50 * [89]	6.50 [165]	13.00 [330]	15.00 [381]	.56 [14]	19.98 [507]	25.50 [648]	31.50 [800]	3.00 [76]	4.98 [126]		
		2.75 † [70]	184C			7.31 [186]	14.62 [371]	16.62 [422]		26.68 [678]	37.25 [946]	43.25 [1098]				
		3.19 † [61]	143TC/145TC													
		4.00 † [102]	182TC/184TC													
			213TC/215TC													
GMS G	1-1/2"	3.50 * [89]	56C	2.00 [51]	3.50 * [89]	6.50 [165]	13.00 [330]	15.00 [381]	.58 [14]	20.11 [511]	25.50 [648]	31.50 [800]	3.00 [76]	5.72 [145]		
		3.75 † [95]	184C			7.31 [186]	14.62 [371]	16.62 [422]		26.81 [681]	37.25 [946]	43.25 [1098]				
	4.00 † [102]	143TC/145TC														
	4.00 † [102]	182TC/184TC	4.50 [114]													
			213TC/215TC		5.25 [133]											
GMS J	2"	4.50 * [114]	182TC/184TC	2.00 [51]	4.50 [114]	7.31 [186]	14.62 [371]	16.62 [422]	.56 [14]	30.20 [767]	32.00 [813]	38.00 [965]	3.00 [76]	8.50 [216]		
	2-1/2"	5.00 † [127]														
		6.00 † [152]	213TC/215TC								5.25 * [133]					
	3"	6.31 † [160]														
GMS N	1-1/2"		182TC/184TC	2.00 [51]	4.50 [114]	7.31 [186]	14.62 [371]	16.62 [422]	.56 [14]	* 29.48 [749]			3.00 [76]	7.59 [193]		
	2"	5.12 * [130]														
	2-1/2"	7.19 † [183]	213TC/215TC							5.25 * [133]						
	3"													* 8.72 [221]		

* STANDARD DIMENSION

† 180° HOUSING

‡ PORTS ARE COMPATIBLE WITH 125# OR 250# ANSI/AST IRON FLANGES. ALL OTHER PORTS ARE TAPPED NPT FOR ANSI PIPE. OPTIONAL (DIN) FLANGES OR TAPPED (BSP) PORTS AVAILABLE FOR EXPORT MARKET.



GRR REDUCER C-FLANGE FLEX DRIVE OPTION DIMENSIONS (213TC - 326TC Frame Size Range)

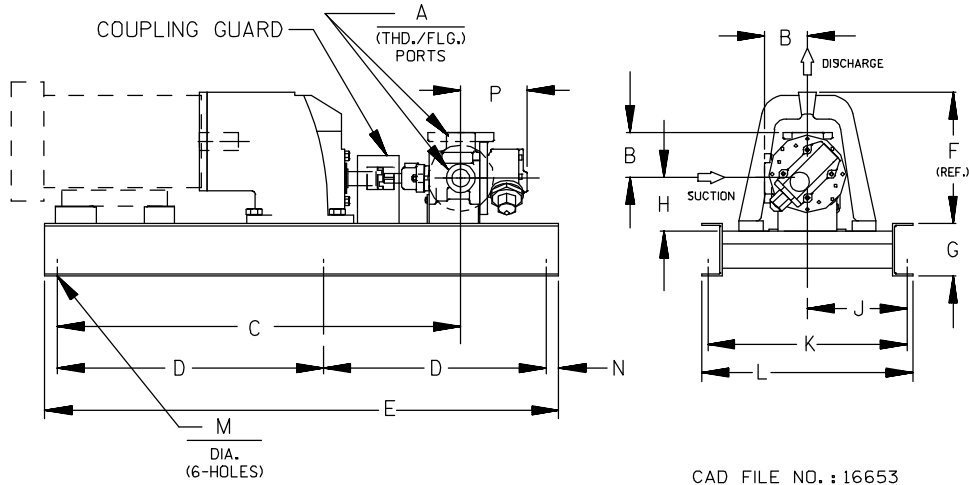

CAD FILE NO. : 16653

PUMP MODEL	PUMP DIMENSIONS														
	A	B	MOTOR FRAME	C	D	E	F	G	H	J	K	L	M	N	P
GMS J	2"	4.50 * [114]	213TC/215TC	41.57 [1056]	23.00 [584]	56.00 [1422]	12.14 [308]								
	2 1/2"	5.00 † [127]	254TC/256TC	42.03 [1068]				8.00 [203]	6.25 [159]	10.12 [257]	20.25 [514]	22.50 [572]	.69 [18]	5.00 [127]	8.49 [216]
		6.00 † [152]	254TC/256TC	44.76 [1137]	24.12 [613]	58.25 [1480]									
	3"	6.31 † [160]	284TC/286TC	46.98 [1183]	25.75 [654]	61.50 [1562]	14.91 [378]								
GMS N	1 1/2"		213TC/215TC	41.98 [1066]											
	2"	5.12 * [130]	213TC/215TC	40.85 [1038]	23.00 [584]	56.00 [1422]	12.14 [308]								
				254TC/256TC	42.42 [1077]				8.00 [152]	6.25 [159]	10.12 [257]	20.25 [514]	22.50 [572]	.69 [18]	5.00 [127]
	2 1/2"	7.19 † [183]	254TC/256TC	45.15 [1147]	24.12 [613]	58.25 [1480]									8.70 [221]
3"		284TC/286TC	47.37 [1203]	25.75 [654]	61.50 [1562]	14.91 [379]								*	
GMS R	2"		184TC	38.50 [978]	22.62 [575]	55.25 [1403]	10.80 [274]								
	2 1/2"	6.50 * [165]	213TC/215TC												
				213TC/215TC	43.80 [1112]	25.28 [642]	60.56 [1538]	12.26 [311]	8.00 [203]	7.00 [178]	10.38 [264]	20.75 [527]	23.00 [584]	.69 [18]	5.00 [127]
	3"	7.19 † [183]	254TC/256TC												
4"		254TC/256TC	48.75 [1238]	27.75 [705]	65.50 [1664]	16.04 [407]									
		284TC/286TC													

* STANDARD DIMENSION

† 180° HOUSING

‡ PORTS ARE COMPATIBLE WITH 125* OR 250* ANSI/AST IRON FLANGES. ALL OTHER PORTS ARE TAPPED NPT FOR ANSI PIPE. OPTIONAL (DIN) FLANGES OR TAPPED (BSP) PORTS AVAILABLE FOR EXPORT MARKET.

CROSS REFERENCE OF MOTOR FRAMES TO GEARBOX RATIOS:

- Ⓐ 2:1, 3.15:1 (15 hp Only), 2.5:1
- Ⓑ 3.15:1 (20 hp Only), 4:1, 5:1
- Ⓒ 2.5:1, 4:1
- Ⓓ 3.15:1, 5:1

REFERENCE: PUMP FOOT BRACKET OPTIONS

MOTOR FRAME	CENTER HEIGHT	PUMP OPTION
213TC thru 286TC	6.25"	80P ("J" & "N" Size Only)
182TC thru 326TC	7.00"	STD ("R" Size Only)



GMS

SEC. 525

PAGE 19
January 2010

GRR REDUCER C-FLANGE FLEX DRIVE OPTIONS

(Drive Assembly Number Includes Base, Coupling, Guard and Gear Reducer, But **NOT** the Motor)

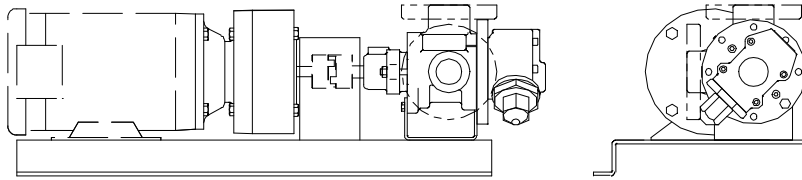

CAD FILE NO.: 16573

PUMP MODEL	RPM @ 1750	RPM @ 1150	REDUCER ①		FRAME	MTG.FT. OPTION REQ.	DRIVE ASSY NO.		
			MAX HP @ 1750	MAX HP @ 1150					
GMS D	875	575	2.00:1	5.65	3.73	56C	STD	90253-510	
				11.70	7.72	143TC/145TC	STD	90253-516	
				11.70	7.72	182C/184C	80F	90253-519	
				13.01	8.59	182TC/184TC	80F	90253-526	
	580	383	3.00:1	3.76	2.48	56C	STD	90253-530	
				8.10	5.35	143TC/145TC	STD	90253-533	
				8.10	5.35	182C/184C	80F	90253-539	
	440	288	4.00:1	10.62	7.01	182TC/184TC	80F	90253-546	
				2.82	1.86	56C	STD	90253-550	
				5.90	3.89	143TC/145TC	STD	90253-553	
	350	230	5.00:1	5.90	3.89	182C/184C	80F	90253-562	
				7.24	4.78	182TC/184TC	80F	90253-566	
				2.26	1.49	56C	STD	90253-570	
				5.20	3.43	143TC/145TC	STD	90253-573	
	GMS G	875	575	2.00:1	5.20	3.43	182C/182C	80F	90253-582
					5.98	3.95	182TC/184TC	80F	90253-586
5.65					3.73	56C	STD	90253-610	
11.70					7.72	143TC/145TC	STD	90253-616	
11.70					7.72	182C/184C	80F	90253-624	
580		383	3.00:1	13.01	8.59	182TC/184TC	80F	90253-626	
				13.01	8.59	213TC/213TC	80J	90253-628	
				3.76	2.48	56C	STD	90253-630	
				8.10	5.35	143TC/145TC	STD	90253-639	
440		288	4.00:1	8.10	5.35	182C/184C	80F	90223-639	
	10.62			7.01	182TC/184TC	80F	90253-646		
	10.62			7.01	213TC/215TC	80J	90253-648		
	2.82			1.86	56C	STD	90253-660		
350	230	5.00:1	5.90	3.89	143TC/145TC	STD	90253-663		
			5.90	3.89	182C/184C	80F	90253-672		
			7.24	4.78	182TC/184TC	80F	90253-675		
			7.24	4.78	213TC	80J	90253-677		
			2.26	1.49	56C	STD	90253-690		
350	230	5.00:1	5.20	3.43	143TC/145TC	STD	90253-693		
			5.20	3.43	182C/184C	80F	90253-702		
			5.89	3.95	182TC/184TC	80F	90253-705		
			5.89	3.95	213TC	80J	90253-707		

(CONT'D)

① Listed reducer horsepower rated for Standard Service (8-10 hrs/day). For Light Service (3-5 hrs/day) multiply maximum rated horsepower by 1.1. For Heavy Service (16-24 hrs/day) multiply maximum rated horsepower by 0.9.

NOTE: CONSULT FACTORY FOR OPTIONS NOT SHOWN.



GMS

GRR REDUCER C-FLANGE FLEX DRIVE OPTIONS

(Drive Assembly Number Includes Base, Coupling, Guard and Gear Reducer, But **NOT** the Motor)

PUMP MODEL	RPM @ 1750	RPM @ 1150	REDUCER ^①		FRAME	MTG.FT. OPTION REQ.	DRIVE ASSY NO.	
			MAX HP @ 1750	MAX HP @ 1150				
GMS J	875	575	2.00:1	13.01	8.59	182TC/184TC	80F	90253-722
				13.01	8.59	213TC/215TC	STD	90253-724
				36.29	23.95	254TC/256TC	80P	90253-728
				36.29	23.95	284TC/286TC	80P	90253-732
	580	383	3.00:1	10.62	7.01	182TC/184TC	80F	90253-735
				10.62	7.01	213TC/215TC	80J	90253-741
	550	365	3.15:1	25.76	17.00	254TC/256TC	80P	90253-743
				25.76	17.00	284TC	80P	90253-746
				42.96	28.35	286TC	80P	90253-747
	440	288	4.00:1	7.24	4.78	182TC/184TC	80F	90253-750
				7.24	4.78	213TC	80J	90253-754
	350	230	5.00:1	5.98	3.95	182TC/184TC	80F	90253-767
				5.98	3.95	213TC	STD	90253-769
				16.01	10.57	215TC	80P	90253-774
				30.49	20.12	254TC/256TC	80J	90253-778
	GMS N	875	575	2.00:1	13.01	8.59	213TC/215TC	STD
36.29					23.95	254TC/256TC	80P	90253-801
36.29					23.95	284TC/286TC	80P	90253-805
580		383	3.00:1	10.62	7.01	213TC/215TC	STD	90253-814
				25.76	17.00	254TC/256TC	80P	90253-819
550		365	3.15:1	42.96	28.35	284TC/286TC	80P	90253-820
				7.24	4.78	213TC	STD	90253-827
350		230	5.00:1	5.98	3.95	213TC	STD	90253-842
				16.01	10.57	215TC	80P	90253-845
				30.49	20.12	254TC/256TC	80P	90253-847
GMS R	640	417	2.76:1	80.20	52.93	324TC	STD	90253-874
				80.20	52.93	364TC	STD	90253-878
	555	365	3.15:1	10.10	6.66	213TC/215TC	STD	90253-881
				25.76	17.00	254TC/256TC	STD	90253-886
				42.96	28.35	284TC/286TC	STD	90253-891
	520	340	3.38:1	66.20	43.69	324TC	STD	90253-896
				66.20	43.69	326TC	STD	90253-898
	440	288	4.00:1	9.42	6.22	184TC	STD	90253-901
				20.00	13.20	213TC/215TC	STD	90253-904
				38.16	25.18	254TC/256TC	STD	90253-909
				38.16	25.18	284TC	STD	90253-913
	420	278	4.13:1	40.40	26.40	286TC	STD	90253-916
				54.40	35.90	324TC	STD	90253-918
	350	230	5.00:1	6.10	4.03	184TC	STD	90253-921
				16.01	10.57	213TC/215TC	STD	90253-924
30.49				20.12	254TC/256TC	STD	90253-929	
30.49				20.12	284TC/286TC	STD	90253-933	

① Listed reducer horsepower rated for Standard Service (8-10 hrs/day). For Light Service (3-5 hrs/day) multiply maximum rated horsepower by 1.1. For Heavy Service (16-24 hrs/day) multiply maximum rated horsepower by 0.9.

NOTE: CONSULT FACTORY FOR OPTIONS NOT SHOWN.

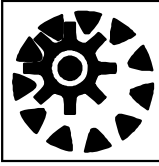

PERFORMANCE CURVES

SPEED VS. CAPACITY/HORSEPOWER

RP Hydraulic Size

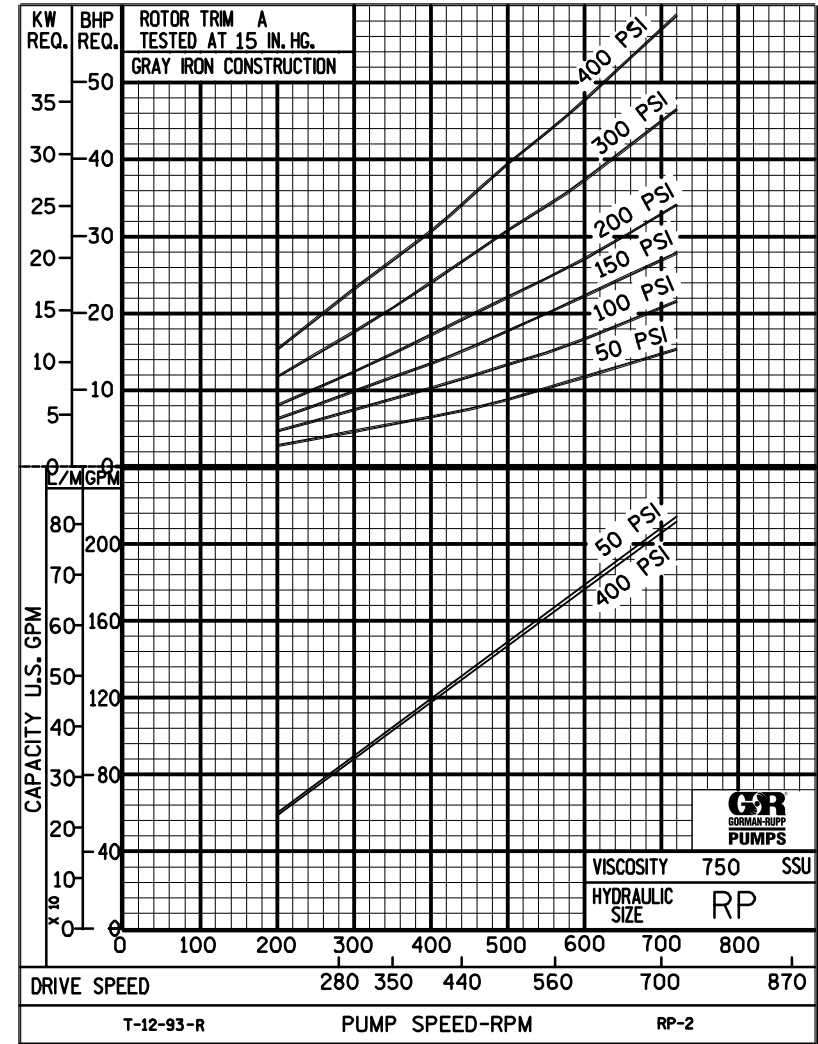
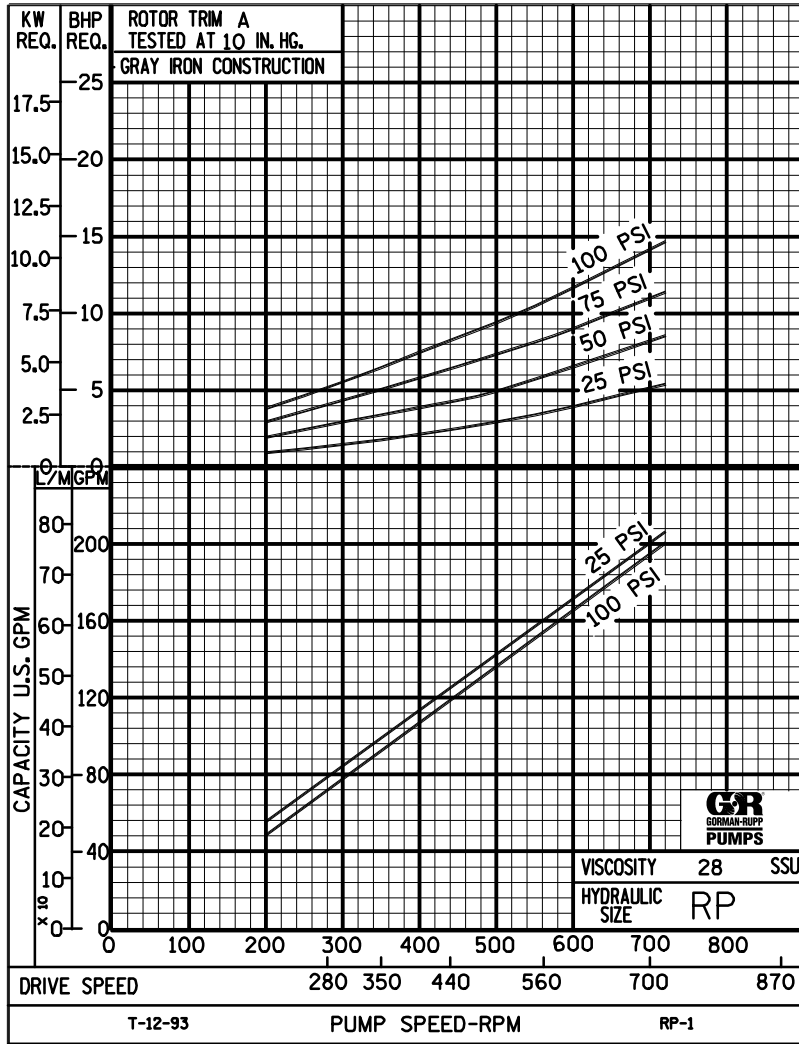

THE GORMAN-RUPP COMPANY • MANSFIELD, OHIO
 GORMAN-RUPP OF CANADA LIMITED • ST. THOMAS, ONTARIO, CANADA

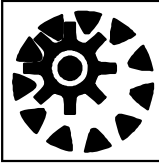

PERFORMANCE CURVES

SPEED VS. CAPACITY/HORSEPOWER

RP Hydraulic Size

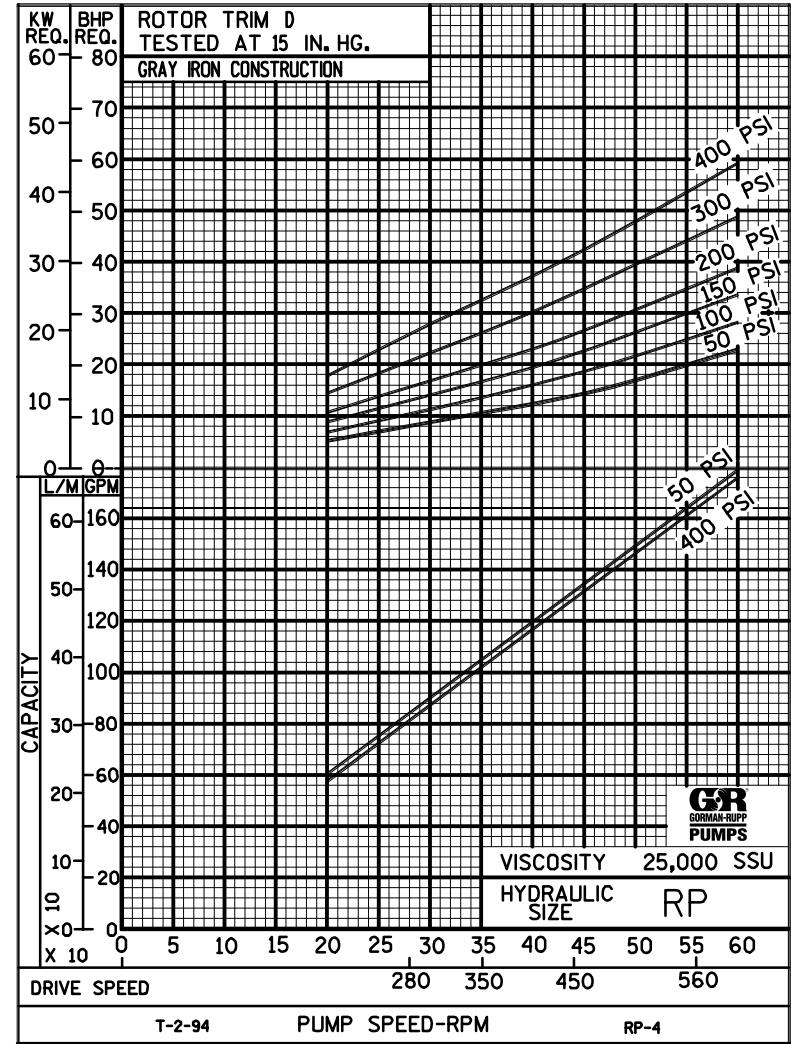
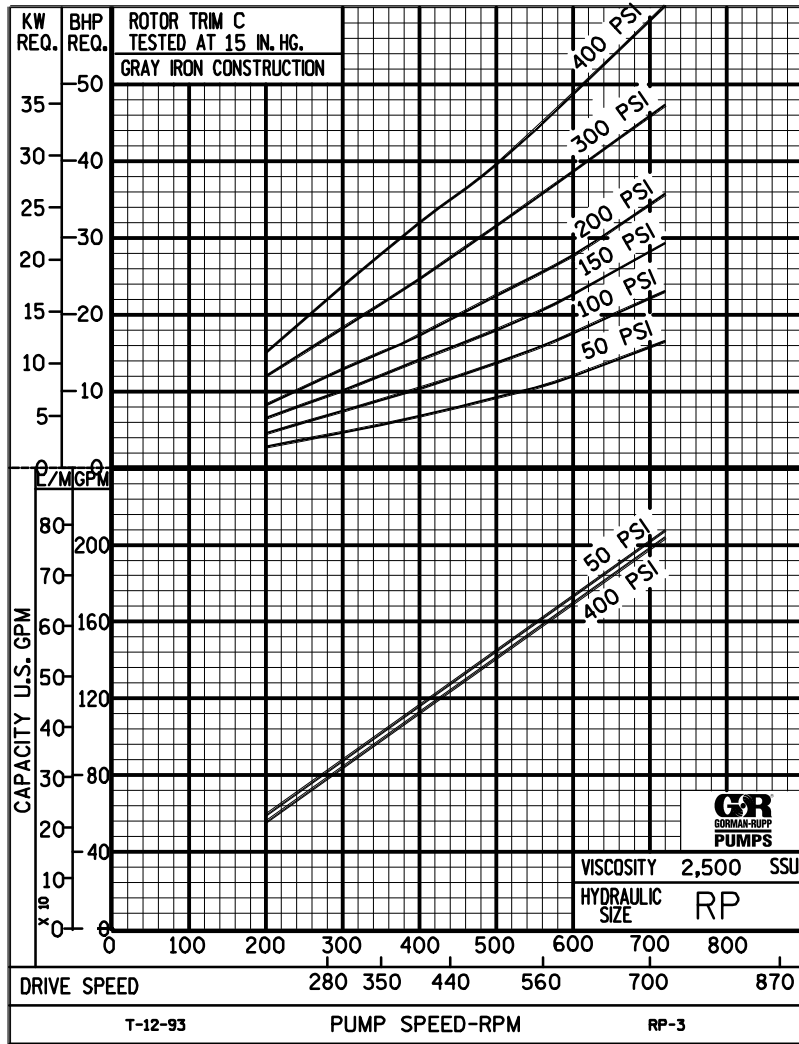

THE GORMAN-RUPP COMPANY • MANSFIELD, OHIO
GORMAN-RUPP OF CANADA LIMITED • ST. THOMAS, ONTARIO, CANADA

Printed in U.S.A.

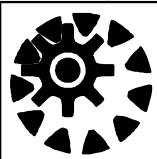

RP

PUMP HYDRAULIC SIZE CHART

SEC. 500

Page 112

January 2010

**215 GPM
720 RPM**

NOMINAL		ROTOR TRIM	VISCOSITY (SSU)	N.I.P.R. (PSIA)	FRICTION PIPE LOSS (PSI/FT) <small>(Based on Sch 40 Steel Pipe)</small>					FULL BYPASS RELIEF VALVE PRESSURE (PSI)					CAPACITY (GPM) / H.P. REQUIRED										
CAP. GPM	SPEED RPM				PIPE DIAMETER					CRACKING PRESS. (PSI)					DIFFERENTIAL PRESSURE (PSI)										
					2"	2 1/2"	3"	4"	6"	LOW PRES R/V			HI PRES R/V		HEAVY DUTY										
							50	75	100	150	200	25	50	75	100	150	200	300	400						
215	720	STD	28	4.0	.31	.13	.04	.01	-	62	87	123	185		206	204	202	200							
			32		.33	.13	.04	.01	-						5.9	8.1	12	15							
			38	4.0	.35	.14	.05	.01	-	64	90	126	187		208	206	204	202	196						
			50		.38	.16	.05	.01	-						7.3	9.3	13	16	23						
			70	4.0	.42	.18	.06	.02	-	69	95	130	192	251		210	208	208	206	202	198				
			100		.46	.20	.07	.02	-							9.3	12	15	18	25	30				
			150	4.0	.51	.22	.08	.02	-	74	99	134	196	258		212	212	210	210	208	204	202	200		
			200		.55	.24	.08	.02	-							11	13	17	20	26	32	45	58		
			300	4.0	.61	.27	.10	.03	-	80	105	140	202	267		214	212	212	212	210	208	206	206		
			500		.72	.31	.11	.02	-							12	15	18	21	28	34	46	59		
		750	4.0	.51	.25	.10	.04	.01	84	110	144	206	274		214	214	214	214	214	212	212	212			
		1,000		.68	.33	.14	.05	.01							13	16	19	22	29	35	47	60			
		2,000	4.3	1.35	.66	.28	.09	.02	92	118	151	213	287		208	208	208	206	206	206	206	204			
		3,500		2.37	1.16	.49	.16	.03							15	17	20	24	30	36	48	61			
		5,000	4.7	3.38	1.66	.70	.24	.05	97	123	156	218	294		208	208	208	208	206	206	206	204			
		7,500		5.08	2.49	1.05	.35	.07							16	19	22	25	32	39	50	63			
		10,000	5.2	6.77	3.32	1.39	.47	.09	102	127	160	222	301		210	208	208	208	208	208	206	206			
		15,000		10.2	4.99	2.09	.71	.14							18	20	24	28	34	41	53	66			
		20,000																							
		25,000																							
50,000																									
75,000																									
100,000																									
150,000																									
200,000																									
250,000																									

(NOTE) For speeds not shown on the pump hydraulic charts, consult factory.

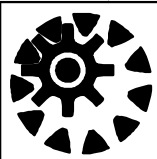

RP

PUMP HYDRAULIC SIZE CHART

SEC. 500

Page 113

January 2010

**190 GPM
640 RPM**

NOMINAL		ROTOR TRIM	VISCOSITY (SSU)	N.I.P.R. (PSIA)	FRICTION PIPE LOSS (PSI/FT) <small>(Based on Sch 40 Steel Pipe)</small>					FULL BYPASS RELIEF VALVE PRESSURE (PSI)					CAPACITY (GPM) / H.P. REQUIRED								
CAP. GPM	SPEED RPM				PIPE DIAMETER					CRACKING PRESS. (PSI)					DIFFERENTIAL PRESSURE (PSI)								
					2"	2 1/2"	3"	4"	6"	LOW PRES R/V		HI PRES R/V			MEDIUM DUTY AND HEAVY DUTY				HEAVY DUTY ONLY				
							50	75	100	150	200	25	50	75	100	150	200	300	400				
190	640	STD	28	3.2	.24	.10	.03	.01	-	60	85	122	180		184	181	179	177					
			32		.26	.10	.04	.01	-						4.9	7.3	10	13					
			38	3.2	.27	.11	.04	.01	-	63	88	124	183		185	182	180	179	174				
			50		.30	.13	.04	.01	-						6.2	8.9	12	15	19				
			70	3.2	.33	.14	.05	.01	-	67	92	128	187	248		187	185	183	178	176			
			100		.37	.16	.06	.02	-							7.9	10	13	16	21	28		
			150	3.2	.41	.17	.06	.02	-	71	97	132	191	253		189	187	186	185	183	181	179	176
			200		.44	.19	.07	.02	-							8.9	12	15	18	22	29	39	50
			300	3.2	.49	.21	.08	.02	-	77	102	136	196	260		190	189	188	188	187	185	184	183
			500		.58	.25	.06	.02	-							10	13	16	19	24	30	40	50
		750	3.2	.45	.22	.09	.03	.01	81	107	140	200	266		191	191	190	190	189	188	188	187	
		1,000		.60	.29	.12	.04	.01							11	13	16	19	24	30	41	51	
		2,000	3.5	1.19	.59	.25	.08	.02	88	114	146	207	276		186	185	185	184	183	183	182	180	
		3,500		2.09	1.03	.43	.15	.03							12	14	18	20	26	31	42	54	
		5,000	3.9	2.98	1.46	.61	.21	.04	93	119	150	211	281		187	186	185	185	184	184	184	181	
		7,500		4.47	2.20	.92	.31	.06							13	16	19	22	28	33	43	57	
		10,000	4.4	5.96	2.93	1.23	.41	.08	97	123	154	215	287		187	186	186	185	185	185	185	182	
		15,000		8.94	4.39	1.84	.62	.12							15	18	21	24	30	35	46	60	
		20,000	5.1	11.9	5.86	2.46	.83	.16	100	126	158	218	292		187	187	186	186	186	186	186	183	
		25,000		14.9	7.32	3.07	1.04	.20							17	20	23	27	32	37	48	63	
50,000																							
75,000																							
100,000																							
150,000																							
200,000																							
250,000																							

(NOTE) For speeds not shown on the pump hydraulic charts, consult factory.

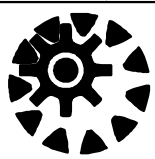

RP

PUMP HYDRAULIC SIZE CHART

SEC. 500

Page 114

January 2010

**155 GPM
520 RPM**

NOMINAL		ROTOR TRIM	VISCOSITY (SSU)	N.I.P.R. (PSIA)	FRICTION PIPE LOSS (PSI/FT) <small>(Based on Sch 40 Steel Pipe)</small>					FULL BYPASS RELIEF VALVE PRESSURE (PSI)					CAPACITY (GPM) / H.P. REQUIRED								
CAP. GPM	SPEED RPM				PIPE DIAMETER					CRACKING PRESS. (PSI)					DIFFERENTIAL PRESSURE (PSI)								
					2"	2 1/2"	3"	4"	6"	LOW PRES R/V		HI PRES R/V			MEDIUM DUTY AND HEAVY DUTY				HEAVY DUTY ONLY				
							50	75	100	150	200	25	50	75	100	150	200	300	400				
155	520	STD	28	2.3	.16	.07	.02	.01	-	57	84	120	178		148	145	143	141					
			32		.17	.07	.02	.01	-						3.3	5.3	7.9	10					
			38	2.3	.19	.08	.03	.01	-	60	86	122	180		149	147	145	143	138				
			50		.20	.09	.03	.01	-						4.6	6.7	9.1	11	16				
			70	2.3	.23	.10	.03	.01	-	63	89	124	183	242		151	149	147	146	143	140		
			100		.25	.11	.04	.01	-							5.9	7.9	10	12	17	22		
			150	2.3	.28	.12	.04	.01	-	66	93	127	186	246		153	152	150	150	148	146	144	141
			200		.31	.13	.05	.01	-							6.7	8.8	11	13	18	22	31	40
			300	2.3	.35	.15	.05	.01	-	72	98	131	190	251		154	153	153	152	151	150	149	148
			500		.41	.12	.05	.02	-							7.6	9.8	12	14	18	23	32	41
		750	2.3	.36	.18	.07	.03	-	75	101	134	193	254		155	155	154	154	153	153	152	152	
		1,000		.48	.24	.10	.03	.01							7.8	10	12	14	19	23	33	41	
		2,000	2.9	.97	.47	.20	.07	.01	82	110	139	199	260		152	151	151	150	149	149	148	146	
		3,500		1.69	.83	.35	.12	.02							8.6	11	13	16	20	24	34	42	
		5,000	3.3	2.42	1.19	.50	.17	.03	86	112	142	202	264		153	152	152	151	151	150	149	148	
		7,500		3.63	1.78	.75	.25	.05							11	13	14	18	23	27	36	44	
		10,000	3.8	4.83	2.37	1.00	.34	.07	89	115	145	205	268		154	153	153	152	152	151	151	149	
		15,000		7.25	3.56	1.49	.50	.10							14	16	19	20	25	29	38	47	
		20,000	4.3	9.67	4.75	1.99	.67	.13	93	118	148	207	272		155	154	154	153	153	152	152	151	
		25,000		12.1	5.94	2.49	.84	.16							16	18	21	23	28	32	41	49	
50,000	6.1	24.2	11.9	4.98	1.68	.33	98	124	151	212	276		155	154	154	153	153	152	152	151			
75,000		36.3	17.8	7.47	2.52	.49							22	24	27	30	34	39	48	57			
100,000																							
150,000																							
200,000																							
250,000																							

(NOTE) For speeds not shown on the pump hydraulic charts, consult factory.

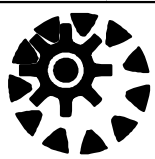

RP

PUMP HYDRAULIC SIZE CHART

SEC. 500

Page 115
January 2010

**105 GPM
350 RPM**

NOMINAL		ROTOR TRIM	VISCOSITY (SSU)	N.I.P.R. (PSIA)	FRICTION PIPE LOSS (PSI/FT) (Based on Sch 40 Steel Pipe)					FULL BYPASS RELIEF VALVE PRESSURE (PSI)					CAPACITY (GPM) / H.P. REQUIRED																				
CAP. GPM	SPEED RPM				PIPE DIAMETER	PIPE DIAMETER					CRACKING PRESS. (PSI)					DIFFERENTIAL PRESSURE (PSI)																			
						2"	2 1/2"	3"	4"	6"	LOW PRES R/V		HI PRES R/V			MEDIUM DUTY AND HEAVY DUTY				HEAVY DUTY ONLY															
105	350	STD	28	1.5	.07	.03	.01	-	-	55	82	118	175		98	95	93	92																	
			32		.08	.03	.01	-	-								1.5	4.1	4.9	6.9															
			38	1.5	.09	.04	.01	-	-	57	83	119	176		99	97	95	94	90																
			50		.10	.04	.01	-	-								2.2	4.3	5.9	7.4	11														
			70	1.5	.11	.05	.02	-	-	59	86	121	177	230	101	99	98	97	95	94															
			100		.13	.05	.02	.01	-								2.9	4.9	6.8	8.3	11	15													
			150	1.5	.14	.06	.02	.01	-	63	89	123	179	233	103	102	101	100	99	98	97	95													
			200		.15	.07	.02	-	-								3.5	5.3	7.2	8.8	12	15	20	27											
			300	1.5	.18	.05	.02	.01	-	67	93	125	181	235	104	103	103	102	102	100	100	99													
			500		.16	.08	.03	.01	-								3.8	5.6	7.4	8.9	12	15	21	27											
		750	1.6	.24	.12	.05	.02	-	70	95	127	183	237	105	105	104	104	103	102	102	101														
		1,000		.32	.16	.07	.02	-								3.9	5.7	7.5	9.1	12	15	21	28												
		2,000	2.0	.64	.32	.13	.04	.01	75	100	130	185	241	103	103	102	102	101	100	99	98														
		3,500		1.13	.55	.23	.08	.02								4.1	6.2	7.9	9.8	13	16	22	29												
		5,000	2.4	1.61	.79	.33	.11	.02	78	104	132	187	243	104	103	103	103	102	101	100	100														
		7,500		2.42	1.19	.50	.17	.03								5.2	7.9	8.9	11	14	17	24	30												
		10,000	2.8	3.22	1.58	.66	.22	.04	81	106	134	189	245	104	104	104	103	103	102	101	100														
		15,000		4.83	2.37	1.00	.34	.07								6.4	9.2	10	12	15	19	25	31												
		20,000	3.3	6.45	3.17	1.33	.45	.09	83	108	136	190	247	105	105	104	104	104	103	103	102														
		25,000		8.06	3.96	1.66	.56	.11								7.5	10	11	13	16	20	26	32												
50,000	5.0	16.1	7.92	3.32	1.12	.22	89	113	137	192	250	105	105	104	104	104	103	103	102																
75,000		24.2	11.9	4.98	1.68	.33								11	13	14	16	20	23	29	35														
100,000	6.9	32.2	15.8	6.64	2.24	.43	92	115	140	194	252	105	105	104	104	104	103	103	102																
150,000		48.4	23.8	9.96	3.36	.65								15	16	18	19	22	26	32	37														
200,000	8.7	64.5	31.7	13.3	4.48	.87	94	117	142	195	253	105	105	104	104	104	103	103	102																
250,000		80.6	39.6	16.6	5.60	1.09								19	21	22	24	24	28	34	40														

(NOTE) For speeds not shown on the pump hydraulic charts, consult factory.