

GMS SERIES
MEDIUM DUTY STANDARD
S & T HYDRAULIC SIZE
ROTARY GEAR PUMP



MODEL GMS6SU3
SHOWN WITH OPTIONAL
180° HOUSING

The GMS iron, high capacity series is designed for applications in the operating ranges noted below. These units are ideal for bulk handling of a variety of liquids. For temperature control, backhead and housing jackets are standard; head jackets are available. Also available are carbon graphite bushings for low viscosity liquids, silicon carbide bushings for wear resistance, and carbide or positive drive shaft seals.

For continuous service, or for handling difficult liquids, see the heavy duty GHS section.

For belt drive applications, a pedestal bearing is required.

FEATURES

*THRUST CONTROLLED PUMP
 ELEMENTS*

*HIGH STRENGTH, COMPUTER
 PROFILED GEARING FOR QUIET
 OPERATION*

*SEAL AREA FULLY JACKETED FOR
 TEMPERATURE CONTROL.*

EXCEPTIONAL SEAL VERSATILITY.

OPERATING RANGE

CAPACITY (GPM) : (40 TO 600)
 [LPM] : [151 TO 2270]

PRESSURE (PSI) : [0 TO 100]
 [BAR] : [0 TO 7]

VISCOSITY (SSU) : (28 TO 250,000)
 [cSt] : [1 TO 55,000]

TEMPERATURE (F) : (-60° TO 500°)
 [C] : [-51° TO 260°]

APPLICATIONS

USE WITH ANY CLEAN LIQUID
 COMPATIBLE WITH CAST
 IRON

- ★ BOOSTER SERVICE
- ★ CIRCULATING
- ★ FILTERING
- ★ LUBRICATING
- ★ TRANSFERRING

THE GORMAN-RUPP COMPANY • MANSFIELD, OHIO

GORMAN-RUPP OF CANADA LIMITED • ST. THOMAS, ONTARIO, CANADA

| EXTERIOR | ROTOR & IDLER | HOUSING PORTS | BUSHINGS | IDLER PIN | SHAFT | SHAFT SEALING | | ROTATION | INTERNAL RELIEF VALVE | |
|-----------|--------------------|---------------|----------|----------------|-------|--------------------------------------|--------------|----------|-----------------------|----------------|
| | | | | | | MECH. SEAL | PACKING | | MATERIAL | SETTING |
| CAST IRON | HIGH STRENGTH IRON | 90° 125# FLG | BRONZE | HARDENED STEEL | STEEL | FLUORO ^① CARBON NI-RESIST | CARBON FIBER | C.W. | CAST IRON | 75 PSI [5 BAR] |

Standard Models

G M S 4 SU 3 - B
 | | | | | | | | | | | |
 GEAR DUTY DESIGN PORT SIZE HYDRAULIC SEAL STYLE
 SIZE SIZE

| MODEL NUMBER | NOM. CAPACITY - SPEED | | MAXIMUM | | | TEMP. | SHIPPING DATA | |
|--|-----------------------|-----|---------------------------------|------------------------------|---------------------------------------|--|--------------------|-------------------|
| | MAXIMUM | | DIFFERENTIAL PRESSURE-PSI [BAR] | | | | Weight LBS [KG] | Volume CU. FT. |
| | GPM [LPM] | RPM | BELOW 38 SSU 14 cSt | 38 TO 100 SSU [21 cSt] | 100 TO 250,000 SSU [55,000 cSt] | °F [°C] | | |
| GMS 3 SR3-B ● GMS 3 SR4-B ■ | 202 [765] | 350 | 50 [3.5] | 75 [5.2] | 100 [7] | ● 400° [204] ■ 500° [260] | 515 [234] | 17.3 |
| GMS 4 SR3-B ● GMS 4 SR4-B ■ | | | | | | | | |
| GMS 6 SR3-B ● † GMS 6 SR4-B ■ † | | | | | | | | |
| GMS 3 SU3-B ● GMS 3 SU4-B ■ | | | | | | | | |
| GMS 4 SU3-B ● GMS 4 SU4-B ■ | | | | | | | | |
| GMS 6 SU3-B ● † GMS 6 SU4-B ■ † | | | | | | | | |
| GMS 5 TU3-B ● GMS 5 TU4-B ■ | 600 [2270] | 350 | 50 [3.5] | 75 [5.2] | 100 [7] | | 715 [324] | 17.3 |
| GMS 6 TU3-B ● GMS 6 TU4-B ■ | | | | | | | | |

● MECHANICAL SEAL

■ PACKING

† PORTS ARE COMPATIBLE WITH 125# ANSI CAST IRON FLANGES.

† 180° DEGREE HOUSING

* Note: Verify chemical compatibility

① DUPONT VITON® OR EQUIVALENT

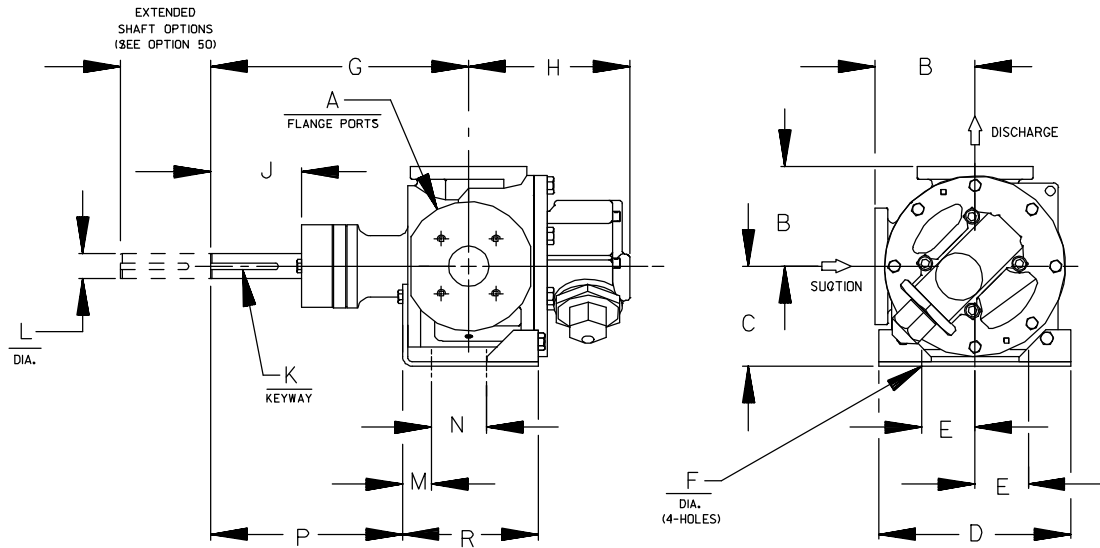

CAD FILE NO.: 17221A

| PUMP MODEL | PUMP DIMENSIONS - INCHES [MILLIMETERS] | | | | | | | | | | | | | | |
|------------|--|--------------|--------------|---------------|------------|----------|-------------|-------------|------------|------------|-----------|-----------|------------|-------------|-------------|
| | A | B | C | D | E | F | G | H | J | K | L | M | N | P | R |
| GMS S | 3.00* | 7.75 [197] | 7.75 [197] * | 8.25 [210] | 4.12 [105] | .69 [18] | 20.00 [508] | 12.49 [317] | 6.90 [178] | .50 [13] | 1.94 [49] | 2.88 [73] | 4.25 [108] | 14.00 [356] | 11.41 [290] |
| | 4.00* | 8.25 [210] | | | | | | | | x | | | | | |
| | 6.00* | 9.00 [229] † | 8.75 [222] | | | | | | | 5.00 [127] | | | | | |
| GMS T | 5.00* | 9.56 [243] | 9.50 [241] | 12.00 [304,8] | 5.00 [127] | .69 [18] | 20.70 [526] | 12.41 [315] | 7.00 [178] | .62 [16] | 2.44 [62] | .81 [21] | 6.25 [159] | 16.45 [418] | 8.50 [216] |
| | 6.00* | 9.52 [244] | | | | | | | | x | | | | | |
| | 6.00* | 9.75 [248] † | | | | | | | | 4.62 [117] | | | | | |

* STANDARD DIMENSION

† 180° HOUSING

THE GORMAN-RUPP COMPANY • MANSFIELD, OHIO
GORMAN-RUPP OF CANADA LIMITED • ST. THOMAS, ONTARIO, CANADA

GRR REDUCER C-FLANGE FLEX DRIVE OPTIONS

(Drive Assembly Number Includes Base, Coupling, Guard and Gear Reducer, But **NOT** the Motor)

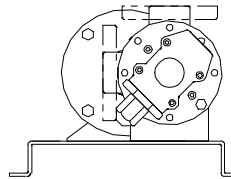
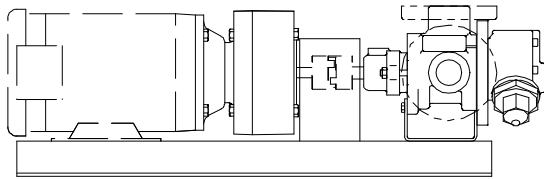

CAD FILE NO.: 16573

| PUMP MODEL | RPM @ 1750 | RPM @ 1150 | REDUCER ① | | FRAME | MTG.FT. OPTION REQ. | DRIVE ASSY NO. | |
|------------|------------|------------|-----------|---------------|-------------|---------------------|----------------|---------------|
| | | | | MAX HP @ 1750 | | | | MAX HP @ 1150 |
| GMS S | 343 | 225 | 5.10:1 | 20.00 | 13.20 | 254TC/256TC | STD | 90253-004 |
| | 344 | 226 | 5.08:1 | 30.00 | 19.80 | 284TC/286TC | STD | 90253-006 |
| | 355 | 233 | 4.93:1 | 60.00 | 39.60 | 324TC | STD | 90253-008 |
| | 283 | 186 | 6.19:1 | 20.00 | 13.20 | 254TC/256TC | STD | 90253-014 |
| | 287 | 189 | 6.09:1 | 30.00 | 19.80 | 284TC/286TC | STD | 90253-016 |
| | 276 | 181 | 6.35:1 | 60.00 | 39.60 | 324TC | STD | 90253-018 |
| | 179 | 117 | 9.80:1 | 10.00 | 6.60 | 213TC | STD | 90253-024 |
| | 206 | 135 | 8.50:1 | 20.00 | 13.20 | 254TC | STD | 90253-026 |
| | | | | 20.00 | 13.20 | 256TC | STD | 90253-027 |
| | 198 | 130 | 8.83:1 | 30.00 | 19.80 | 284TC | STD | 90253-028 |
| | | | | 30.00 | 19.80 | 286TC | STD | 90253-029 |
| | 120 | 79 | 14.55:1 | 10.00 | 6.60 | 213TC | STD | 90253-034 |
| | 125 | 82 | 14.00:1 | 30.00 | 19.80 | 254TC | STD | 90253-036 |
| | | | | 30.00 | 19.80 | 256TC | STD | 90253-037 |
| 105 | 69 | 16.66:1 | 7.81 | 5.16 | 184TC | STD | 90253-044 | |
| | | | 17.71:1 | 16.48 | 10.88 | 213TC | STD | 90253-046 |
| 99 | 65 | 17.81:1 | 26.41 | 17.43 | 254TC | STD | 90253-048 | |
| | | | | | | | | |
| GMS T | 279 | 186 | 6.19:1 | 20.00 | 13.20 | 254TC/256TC | STD | 90253-104 |
| | 287 | 189 | 6.09:1 | 30.00 | 19.80 | 284TC/286TC | STD | 90253-106 |
| | 276 | 181 | 6.35:1 | 60.00 | 39.60 | 324TC | STD | 90253-108 |
| | | | | 60.00 | 39.60 | 326TC | STD | 90253-109 |
| | | | | 60.00 | 39.60 | 364TC | STD | 90253-110 |
| | 179 | 117 | 9.80:1 | 10.00 | 6.60 | 213TC | STD | 90253-114 |
| | 206 | 135 | 8.50:1 | 20.00 | 13.20 | 254TC/256TC | STD | 90253-116 |
| | 198 | 130 | 8.83:1 | 30.00 | 19.80 | 284TC | STD | 90253-118 |
| | | | | 30.00 | 19.80 | 286TC | STD | 90253-119 |
| | 199 | 131 | 8.78:1 | 60.00 | 39.60 | 324TC | STD | 90253-120 |
| | 119 | 79 | 14.55:1 | 10.00 | 6.60 | 213TC | STD | 90253-124 |
| | 125 | 82 | 14.00:1 | 30.00 | 19.80 | 254TC/256TC | STD | 90253-126 |
| | | | | 30.00 | 19.80 | 284TC | STD | 90253-128 |
| | 104 | 69 | 16.66:1 | 7.81 | 5.16 | 184TC | STD | 90253-134 |
| 17.71:1 | | | | 16.48 | 10.88 | 213TC | STD | 90253-136 |
| 97 | 65 | 17.81:1 | 26.41 | 17.43 | 254TC/256TC | STD | 90253-138 | |
| | | | | | | | | |

① Listed reducer horsepower rated for Standard Service (8-10 hrs/day). For Light Service (3-5 hrs/day) multiply maximum rated horsepower by 1.1. For Heavy Service (16-24 hrs/day) multiply maximum rated horsepower by 0.9.

NOTE: CONSULT FACTORY FOR OPTIONS NOT SHOWN.



PERFORMANCE CURVES

SPEED VS. CAPACITY/HORSEPOWER

SR

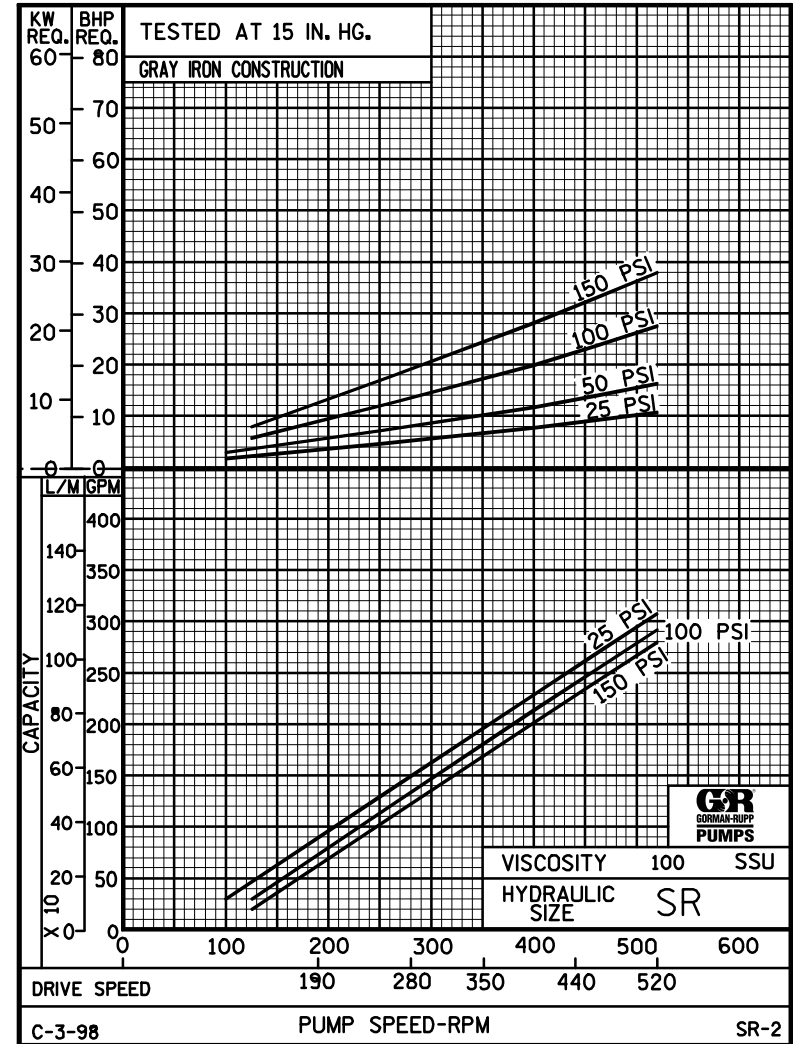
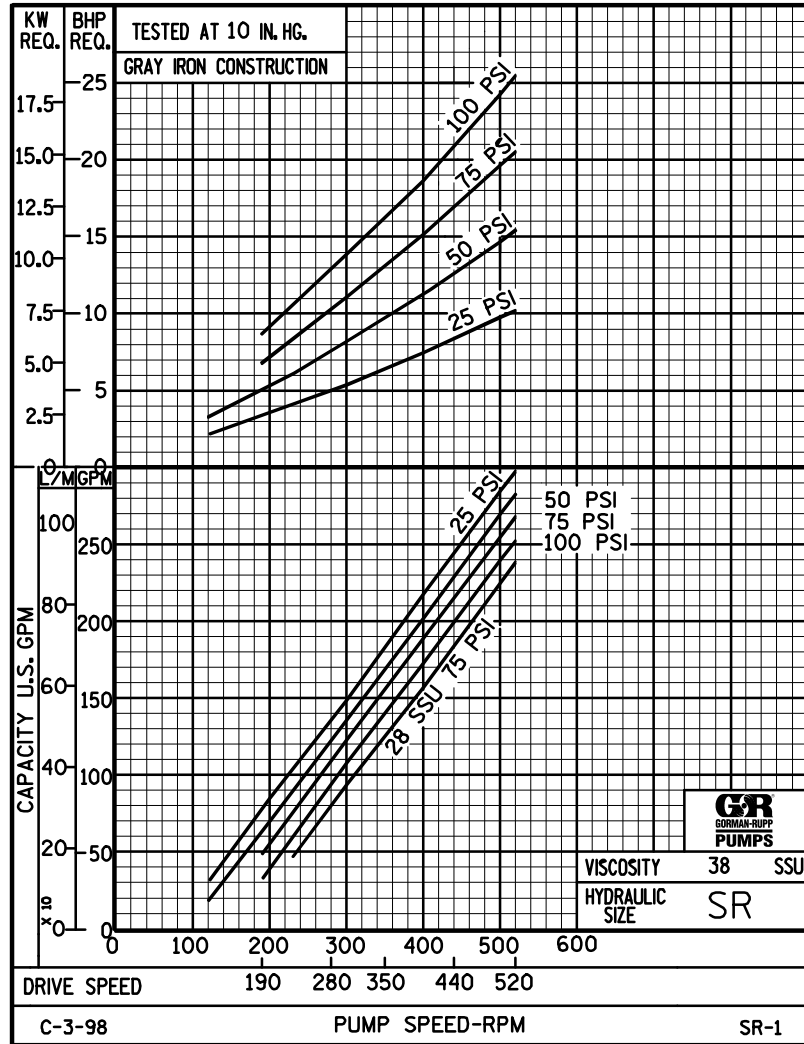
 Hydraulic Size

THE GORMAN-RUPP COMPANY • MANSFIELD, OHIO
GORMAN-RUPP OF CANADA LIMITED • ST. THOMAS, ONTARIO, CANADA

Printed in U.S.A.

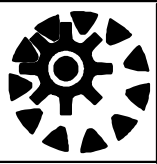

PERFORMANCE CURVES

SPEED VS. CAPACITY/HORSEPOWER

SR

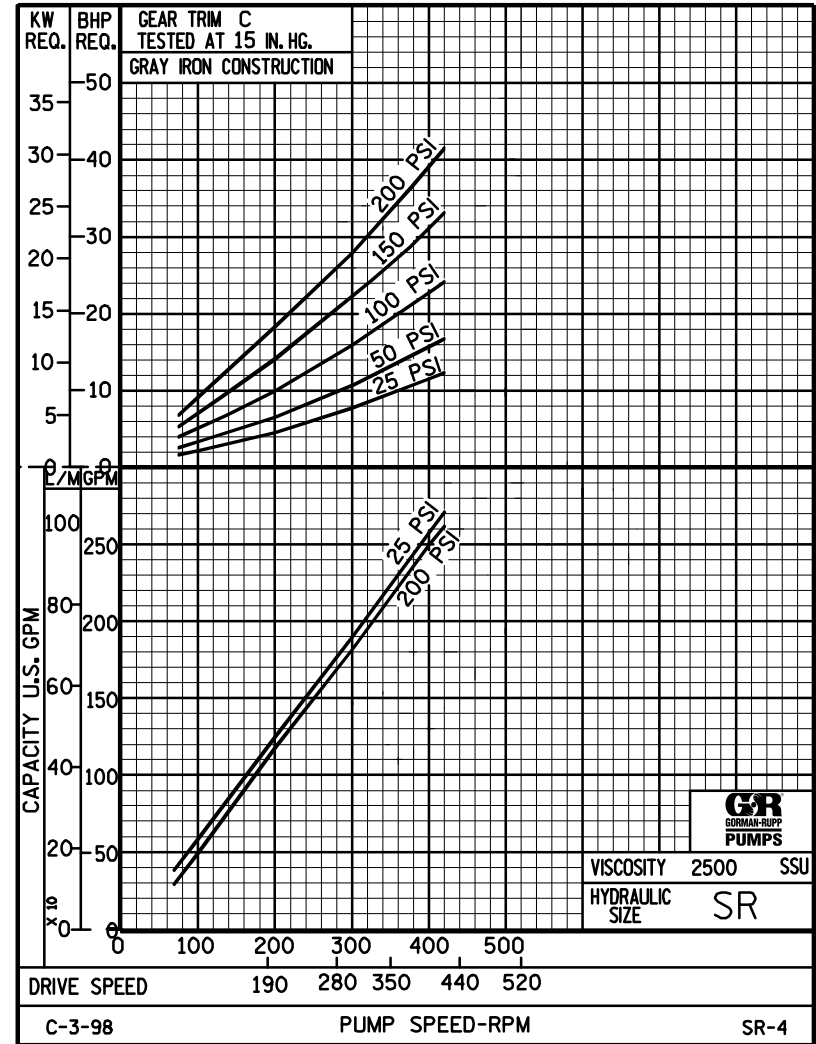
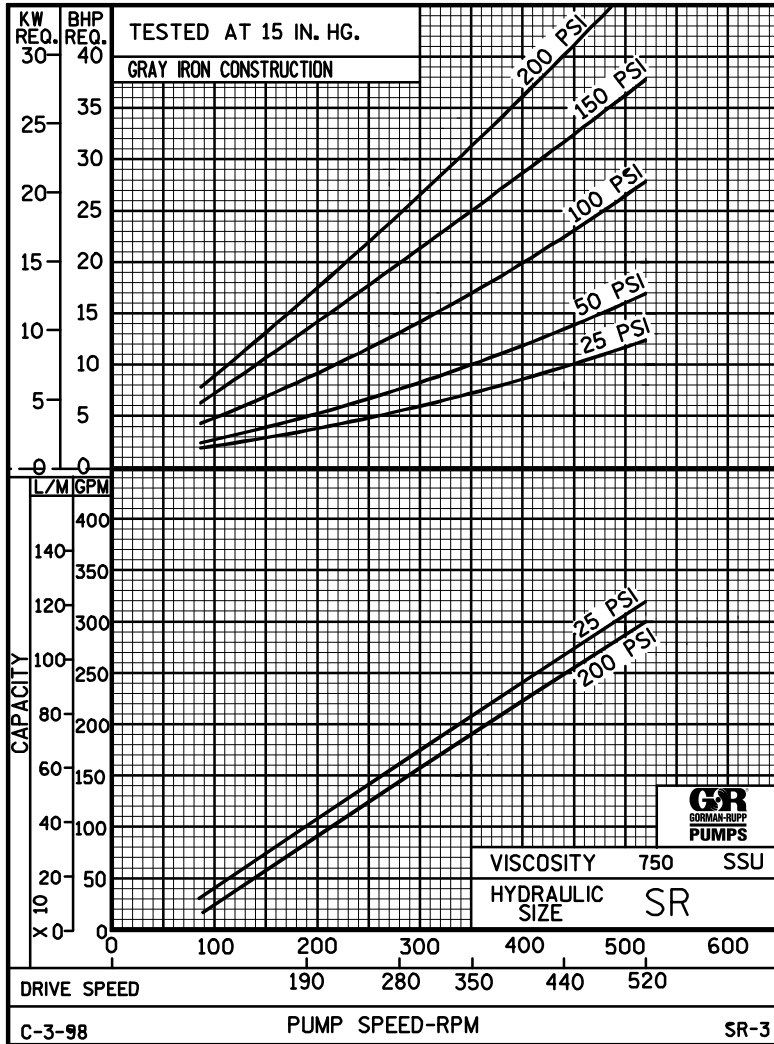
 Hydraulic Size

THE GORMAN-RUPP COMPANY • MANSFIELD, OHIO
 GORMAN-RUPP OF CANADA LIMITED • ST. THOMAS, ONTARIO, CANADA

Printed in U.S.A.

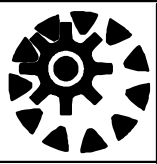

PERFORMANCE CURVES

SPEED VS. CAPACITY/HORSEPOWER

SR

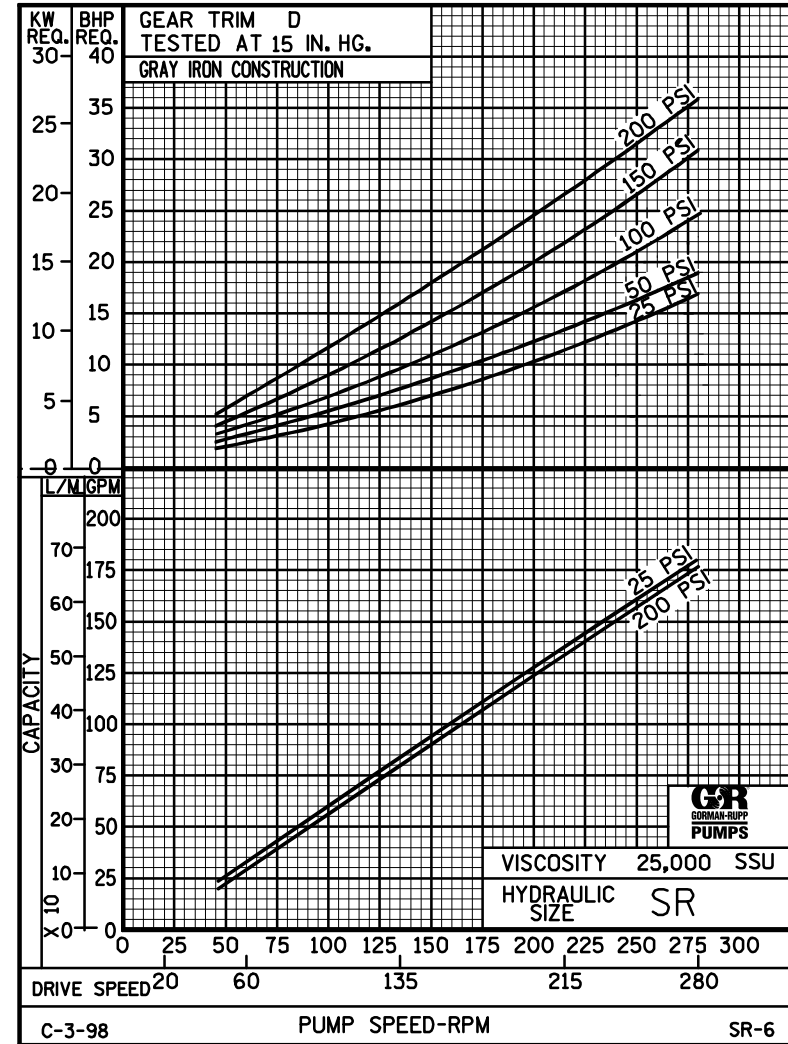
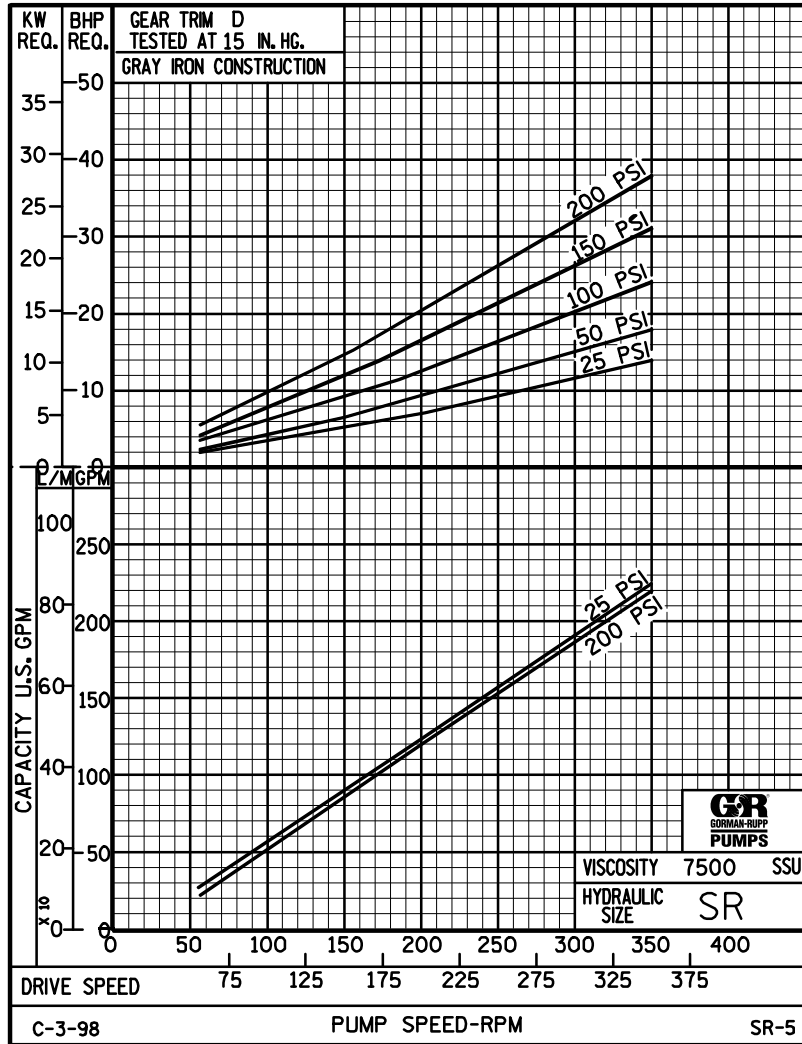
 Hydraulic Size

THE GORMAN-RUPP COMPANY • MANSFIELD, OHIO
GORMAN-RUPP OF CANADA LIMITED • ST. THOMAS, ONTARIO, CANADA

Printed in U.S.A.



PERFORMANCE CURVES

SPEED VS. CAPACITY/HORSEPOWER

SR

Hydraulic Size

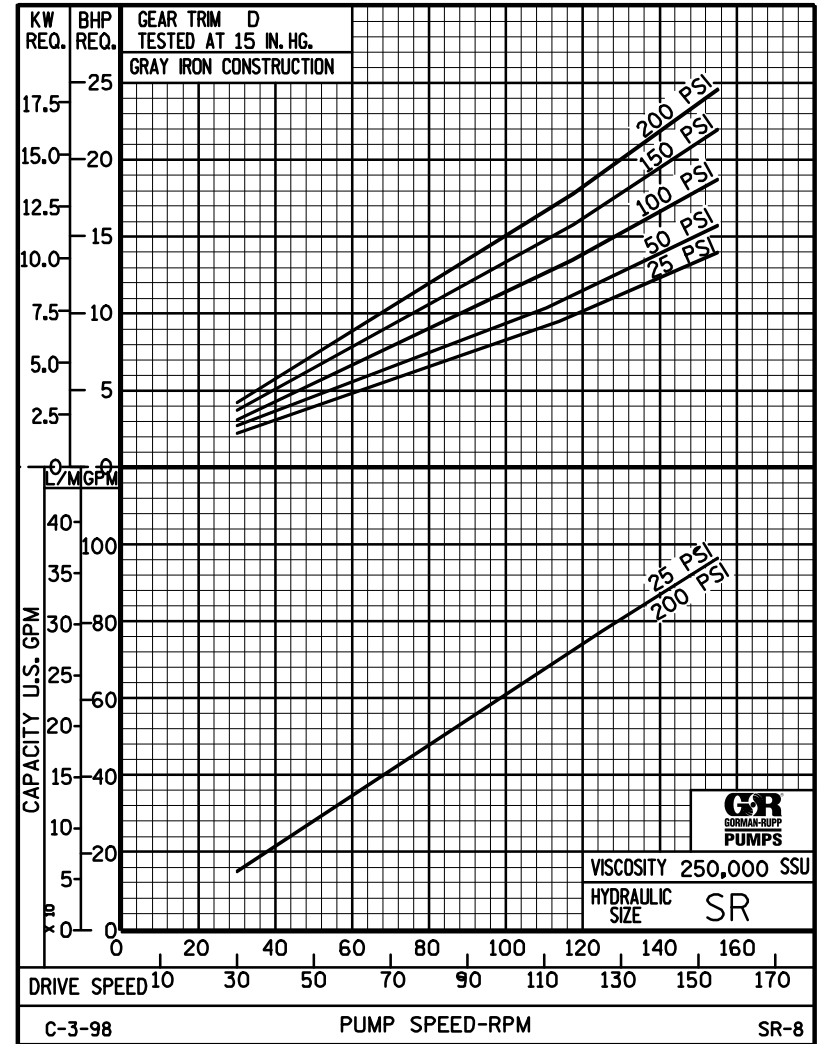
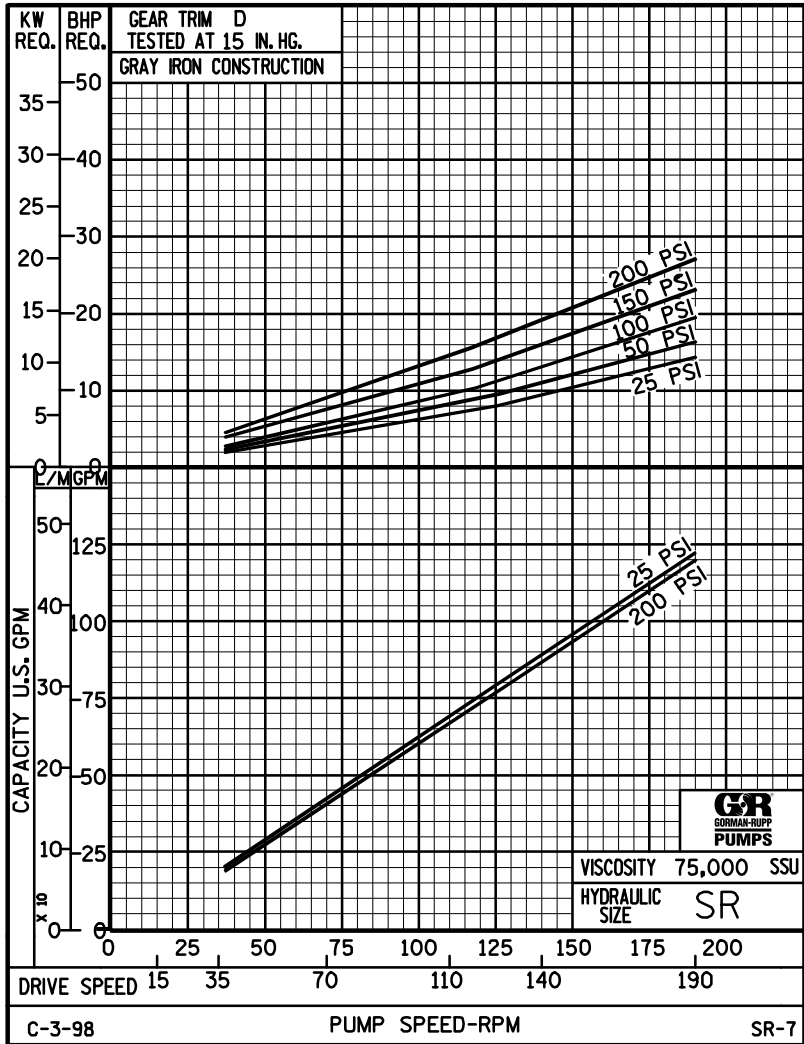

THE GORMAN-RUPP COMPANY • MANSFIELD, OHIO
GORMAN-RUPP OF CANADA LIMITED • ST. THOMAS, ONTARIO, CANADA

Printed in U.S.A.