

---

**INSTALLATION, OPERATION,  
AND MAINTENANCE MANUAL**  
WITH PARTS LIST



**ULTRA V PUMP**

MODEL
<b>VS3A60—B</b> INCLUDING: /WW

**THE GORMAN-RUPP COMPANY • MANSFIELD, OHIO**

[www.grpumps.com](http://www.grpumps.com)

GORMAN-RUPP OF CANADA LIMITED • ST. THOMAS, ONTARIO, CANADA Printed in U.S.A.

©2006 The Gorman-Rupp Company

Register your new  
Gorman-Rupp pump online at  
**www.grpumps.com**

Valid serial number and e-mail address required.

**RECORD YOUR PUMP MODEL AND SERIAL NUMBER**

Please record your pump model and serial number in the spaces provided below. Your Gorman-Rupp distributor needs this information when you require parts or service.

Pump Model: \_\_\_\_\_

Serial Number: \_\_\_\_\_

# TABLE OF CONTENTS

<b>INTRODUCTION</b> .....	<b>PAGE I – 1</b>
<b>SAFETY – SECTION A</b> .....	<b>PAGE A – 1</b>
<b>INSTALLATION – SECTION B</b> .....	<b>PAGE B – 1</b>
Pump Dimensions .....	PAGE B – 1
<b>PREINSTALLATION INSPECTION</b> .....	<b>PAGE B – 1</b>
<b>POSITIONING PUMP</b> .....	<b>PAGE B – 1</b>
Lifting .....	PAGE B – 1
Mounting .....	PAGE B – 2
Clearance .....	PAGE B – 2
<b>SUCTION AND DISCHARGE PIPING</b> .....	<b>PAGE B – 2</b>
Materials .....	PAGE B – 2
Line Configuration .....	PAGE B – 2
Connections to Pump .....	PAGE B – 2
Gauges .....	PAGE B – 2
<b>SUCTION LINES</b> .....	<b>PAGE B – 2</b>
Fittings .....	PAGE B – 2
Strainers .....	PAGE B – 2
Sealing .....	PAGE B – 3
Suction Lines In Sumps .....	PAGE B – 3
Suction Line Positioning .....	PAGE B – 3
<b>DISCHARGE LINES</b> .....	<b>PAGE B – 4</b>
Siphoning .....	PAGE B – 4
Valves .....	PAGE B – 4
Bypass Lines .....	PAGE B – 4
<b>AUTOMATIC AIR RELEASE VALVE</b> .....	<b>PAGE B – 5</b>
Air Release Valve Installation .....	PAGE B – 6
<b>DRIVE ARRANGEMENTS</b> .....	<b>PAGE B – 7</b>
Dual Motor Drives .....	PAGE B – 7
Single Motor Belt Drives .....	PAGE B – 7
Single Motor Combination Drives .....	PAGE B – 8
<b>HIGH PUMP TEMPERATURE SHUTDOWN FOR STAGED APPLICATIONS</b> .....	<b>PAGE B – 9</b>
<b>ALIGNMENT</b> .....	<b>PAGE B – 9</b>
Coupled Drives .....	PAGE B – 9
Drive Belts .....	PAGE B – 10
<b>DRIVE BELT TENSIONING</b> .....	<b>PAGE B – 10</b>
General Rules of Tensioning .....	PAGE B – 10
<b>OPERATION – SECTION C</b> .....	<b>PAGE C – 1</b>
<b>PRIMING</b> .....	<b>PAGE C – 1</b>
<b>STARTING</b> .....	<b>PAGE C – 1</b>
Rotation .....	PAGE C – 1
<b>OPERATION</b> .....	<b>PAGE C – 2</b>
Lines With a Bypass .....	PAGE C – 2
Lines Without a Bypass .....	PAGE C – 2
Leakage .....	PAGE C – 2
Liquid Temperature And Overheating .....	PAGE C – 2
Strainer Check .....	PAGE C – 3

**TABLE OF CONTENTS**  
**(continued)**

Pump Vacuum Check .....	PAGE C – 3
STOPPING .....	PAGE C – 3
Cold Weather Preservation .....	PAGE C – 3
BEARING TEMPERATURE CHECK .....	PAGE C – 3
<b>TROUBLESHOOTING – SECTION D .....</b>	<b>PAGE D – 1</b>
PREVENTIVE MAINTENANCE .....	PAGE D – 3
<b>PUMP MAINTENANCE AND REPAIR – SECTION E .....</b>	<b>PAGE E – 1</b>
PERFORMANCE CURVE .....	PAGE E – 1
PARTS LISTS:	
VS3A60–B And VS3A60–B /WW Pump Models .....	PAGE E – 3
Pump Assemblies 46167–037 And 46146–038 .....	PAGE E – 5
46146–010 Ultra Mate Pump Assembly .....	PAGE E – 7
Repair Rotating Assemblies .....	PAGE E – 9
PUMP AND SEAL DISASSEMBLY AND REASSEMBLY .....	PAGE E – 10
Support Plare Removal .....	PAGE E – 11
Back Cover And Wear Plate Removal .....	PAGE E – 11
Rotating Assembly Removal .....	PAGE E – 11
Impeller Removal .....	PAGE E – 12
Seal Removal .....	PAGE E – 12
Shaft and Bearing Removal and Disassembly .....	PAGE E – 12
Pump Casing and Transition Chamber Removal .....	PAGE E – 13
Pump Casing and Transition Chamber Installation .....	PAGE E – 14
Shaft and Bearing Reassembly and Installation .....	PAGE E – 14
Seal Installation .....	PAGE E – 15
Impeller Installation And Adjustment .....	PAGE E – 18
Rotating Assembly Installation .....	PAGE E – 18
Back Cover Installation And Adjustment .....	PAGE E – 18
PRESSURE RELIEF VALVE MAINTENANCE .....	PAGE E – 19
Final Pump Assembly .....	PAGE E – 20
LUBRICATION .....	PAGE E – 20
Seal Assembly .....	PAGE E – 20
Bearings .....	PAGE E – 20
Power Source .....	PAGE E – 20

## INTRODUCTION

**Thank You** for purchasing a Gorman-Rupp pump. **Read this manual** carefully to learn how to safely install and operate your pump. Failure to do so could result in personal injury or damage to the pump. This Installation, Operation, and Maintenance manual is designed to help you achieve the best performance and longest life from your Gorman-Rupp pump.

This Installation, Operation, and Maintenance manual is designed to help you achieve the best performance and longest life from your Gorman-Rupp pump.

Ultra V Series pumps are designed for handling liquids containing large entrained solids and slurries. The basic material of construction for Ultra V Series pumps is cast iron, with ductile iron impeller and steel wearing parts.

If there are any questions regarding the pump or its application which are not covered in this manual or in other literature accompanying this unit, please contact your Gorman-Rupp distributor, or:

**The Gorman-Rupp Company**  
**P.O. Box 1217**  
**Mansfield, Ohio 44901-1217**  
**Phone: (419) 755-1011**  
 or:  
**Gorman-Rupp of Canada Limited**  
**70 Burwell Road**  
**St. Thomas, Ontario N5P 3R7**  
**Phone: (519) 631-2870**

For information or technical assistance on the power source, contact the power source manufacturer's local dealer or representative.

This manual will alert personnel to known procedures which require special attention, to those which could damage equipment, and to those which could be dangerous to personnel. However, this manual cannot possibly anticipate and provide detailed precautions for every situation that might occur during maintenance of the unit. Therefore, it is the responsibility of the owner/maintenance personnel to ensure that **only** safe, established maintenance procedures are used, and that any proce-

dures not addressed in this manual are performed **only** after establishing that neither personal safety nor pump integrity are compromised by such practices.

The following are used to alert maintenance personnel to procedures which require special attention, to those which could damage equipment, and to those which could be dangerous to personnel:



**Immediate hazards which WILL result in severe personal injury or death. These instructions describe the procedure required and the injury which will result from failure to follow the procedure.**



**Hazards or unsafe practices which COULD result in severe personal injury or death. These instructions describe the procedure required and the injury which could result from failure to follow the procedure.**



Hazards or unsafe practices which COULD result in minor personal injury or product or property damage. These instructions describe the requirements and the possible damage which could result from failure to follow the procedure.

### NOTE

*Instructions to aid in installation, operation, and maintenance or which clarify a procedure.*

## SAFETY – SECTION A

This information applies to Ultra V Series pumps. Gorman-Rupp has no control over or particular knowledge of the power source which will be used. Refer to the manual accompanying the power source before attempting to begin operation.

Because pump installations are seldom identical, this manual cannot possibly provide detailed instructions and precautions for each specific application. Therefore, it is the owner/installer's responsibility to ensure that applications not addressed in this manual are performed only after establishing that neither operator safety nor pump integrity are compromised by the installation.



Before attempting to open or service the pump:

1. Familiarize yourself with this manual.
2. Disconnect or lock out the power source to ensure that the pump will remain inoperative.
3. Allow the pump to completely cool if overheated.
4. Check the temperature before opening any covers, plates, or plugs.
5. Close the suction and discharge valves.
6. Vent the pump slowly and cautiously.
7. Drain the pump.



This pump is designed to handle liquids

containing large entrained solids or slurries. Do not attempt to pump volatile, corrosive, or flammable materials which may damage the pump or endanger personnel as a result of pump failure.



After the pump has been positioned, make certain that the pump and all piping connections are tight, properly supported and secure before operation.



Do not operate the pump without the guards in place over the rotating parts. Exposed rotating parts can catch clothing, fingers, or tools, causing severe injury to personnel.



Do not remove plates, covers, gauges, pipe plugs, or fittings from an overheated pump. Vapor pressure within the pump can cause parts being disengaged to be ejected with great force. Allow the pump to completely cool before servicing.



Do not operate the pump against a closed discharge valve for long periods of time. If operated against a closed discharge valve, pump components will deteriorate, and the liquid could come to a boil, build pressure, and cause the pump casing to rupture or explode.

**WARNING!**

Use lifting and moving equipment in good repair and with adequate capacity to prevent injuries to personnel or damage to equipment. Suction and discharge hoses and piping must be removed from the pump before lifting.

**WARNING!**

**Do not** install a suction check valve in the first stage of the VS Series pump model. Installing a suction check valve in the first stage of the VS Series pump model can cause over-pressurization of the first stage pump casing, resulting in possible explosion of the pump and serious injury or death to personnel.

**WARNING!**

Do not attempt to disengage any part of an overheated pump unit. Vapor pressure within the pump casing can eject these parts with great force when they are disengaged. Allow the pump to completely cool before servicing it.

**CAUTION**

Pumps and related equipment must be installed and operated according to all national, local and industry standards.

## INSTALLATION – SECTION B

### Review all SAFETY information in Section A.

Since pump installations are seldom identical, this section offers only general recommendations and practices required to inspect, position, and arrange the pump and piping.

Most of the information pertains to a standard **static lift application** where the pump is positioned above the free level of liquid to be pumped.

If installed in a **flooded suction application** where the liquid is supplied to the pump under pressure, some of the information such as mounting, line configuration, and priming must be tailored to the specific application. Since the pressure supplied to the pump is critical to performance and safety, **be sure** to limit the incoming pressure to **50%** of the maximum permissible operating pressure as shown on the pump performance curve.

For further assistance, contact your Gorman-Rupp distributor or the Gorman-Rupp Company.

### Pump Dimensions

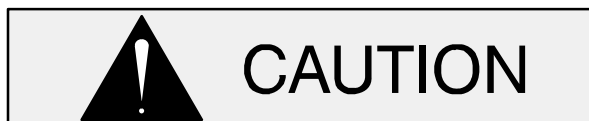
Consult the pump Specification Data Sheet or consult the factory for the approximate physical dimensions of your pump.

### PREINSTALLATION INSPECTION

The pump assembly was inspected and tested before shipment from the factory. Before installation, inspect the pump for damage which may have occurred during shipment. Check as follows:

- Inspect the pump for cracks, dents, damaged threads, and other obvious damage.
- Check for and tighten loose attaching hardware. Since gaskets tend to shrink after drying, check for loose hardware at mating surfaces.
- Carefully read all warnings and cautions contained in this manual or affixed to the pump, and perform all duties indicated. Note the direction of rotation indicated on the pump.

Check that the pump shaft rotates counter-clockwise when facing the impeller.



Only operate this pump in the direction indicated by the arrow on the pump body and on the accompanying decal. Refer to **ROTATION** in **OPERATION**, Section C.

- Check levels and lubricate as necessary. Refer to **LUBRICATION** in the **MAINTENANCE AND REPAIR** section of this manual and perform duties as instructed.
- If the pump and power source have been stored for more than 12 months, some of the components or lubricants may have exceeded their maximum shelf life. These **must be inspected or replaced** to ensure maximum pump service.

If the maximum shelf life has been exceeded, or if anything appears to be abnormal, contact your Gorman-Rupp distributor or the factory to determine the repair or updating policy. **Do not** put the pump into service until appropriate action has been taken.

### POSITIONING PUMP

#### Lifting

Pump unit weights will vary depending on the mounting and drive provided. Check the shipping tag on the unit packaging for the actual weight, and use lifting equipment with appropriate capacity. Drain the pump and remove all customer-installed equipment such as suction and discharge hoses or piping before attempting to lift existing, installed units.



The pump assembly can be seriously damaged if the cables or chains used to lift



and move the unit are improperly wrapped around the pump.

### Mounting

Locate the pump in an accessible place as close as practical to the liquid being pumped. Level mounting is essential for proper operation.

The pump may have to be supported or shimmed to provide for level operation or to eliminate vibration.

### Clearance

It is recommended that **18 inches (457 mm)** of clearance be provided in front of the back cover to permit removal of the cover and easy access to the pump interior. A **minimum** clearance of **10–1/2 inches (267 mm)** must be maintained to permit removal of the cover.

## SUCTION AND DISCHARGE PIPING

Pump performance is adversely effected by increased suction lift, discharge elevation, and friction losses. See the performance curve and operating range shown on Page E-1 to be sure your overall application allows pump to operate within the safe operation range.

### Materials

Either pipe or hose may be used for suction and discharge lines; however, the materials must be compatible with the liquid being pumped. If hose is used in suction lines, it must be the rigid-wall, reinforced type to prevent collapse under suction. Using piping couplings in suction lines is not recommended.

### Line Configuration

Keep suction and discharge lines as straight as possible to minimize friction losses. Make minimum use of elbows and fittings, which substan-

tially increase friction loss. If elbows are necessary, use the long-radius type to minimize friction loss.

### Connections to Pump

Before tightening a connecting flange, align it exactly with the pump port. Never pull a pipe line into place by tightening the flange bolts and/or couplings.

Lines near the pump must be independently supported to avoid strain on the pump which could cause excessive vibration, decreased bearing life, and increased shaft and seal wear. If hose-type lines are used, they should have adequate support to secure them when filled with liquid and under pressure.

### Gauges

Most pumps are drilled and tapped for installing discharge pressure and vacuum suction gauges. If these gauges are desired for pumps that are not tapped, drill and tap the suction and discharge lines not less than 18 inches (457,2 mm) from the suction and discharge ports and install the lines. Installation closer to the pump may result in erratic readings.

## SUCTION LINES

To avoid air pockets which could affect pump priming, the suction line must be as short and direct as possible. When operation involves a suction lift, the line must always slope upward to the pump from the source of the liquid being pumped; if the line slopes down to the pump at any point along the suction run, air pockets will be created.

### Fittings

Suction lines should be the same size as the pump inlet. If reducers are used in suction lines, they should be the eccentric type, and should be installed with the flat part of the reducers uppermost to avoid creating air pockets. Valves are not normally used in suction lines, but if a valve is used, install it with the stem horizontal to avoid air pockets.

### Strainers

If a strainer is furnished with the pump, be certain to use it; any spherical solids which pass through a

strainer furnished with the pump will also pass through the pump itself.

If a strainer is not furnished with the pump, but is installed by the pump user, make certain that the total area of the openings in the strainer is at least three or four times the cross section of the suction line, and that the openings will not permit passage of solids larger than the solids handling capability of the pump.

This pump is designed to handle up to 2-1/2 inch (63,5 mm) diameter spherical solids.

### Sealing

Since even a slight leak will affect priming, head, and capacity, especially when operating with a high suction lift, all connections in the suction line should be sealed with pipe dope to ensure an airtight seal. Follow the sealant manufacturer's recommendations when selecting and applying the pipe dope. The pipe dope should be compatible with the liquid being pumped.

### Suction Lines In Sumps

If a single suction line is installed in a sump, it should be positioned away from the wall of the sump at a distance equal to 1 1/2 times the diameter of the suction line.

If there is a liquid flow from an open pipe into the sump, the flow should be kept away from the suc-

tion inlet because the inflow will carry air down into the sump, and air entering the suction line will reduce pump efficiency.

If it is necessary to position inflow close to the suction inlet, install a baffle between the inflow and the suction inlet at a distance 1 1/2 times the diameter of the suction pipe. The baffle will allow entrained air to escape from the liquid before it is drawn into the suction inlet.

If two suction lines are installed in a single sump, the flow paths may interact, reducing the efficiency of one or both pumps. To avoid this, position the suction inlets so that they are separated by a distance equal to at least 3 times the diameter of the suction pipe.

### Suction Line Positioning

The depth of submergence of the suction line is critical to efficient pump operation. Figure 1 shows recommended minimum submergence vs. velocity.

### NOTE

*The pipe submergence required may be reduced by installing a standard pipe increaser fitting at the end of the suction line. The larger opening size will reduce the inlet velocity. Calculate the required submergence using the following formula based on the increased opening size (area or diameter).*

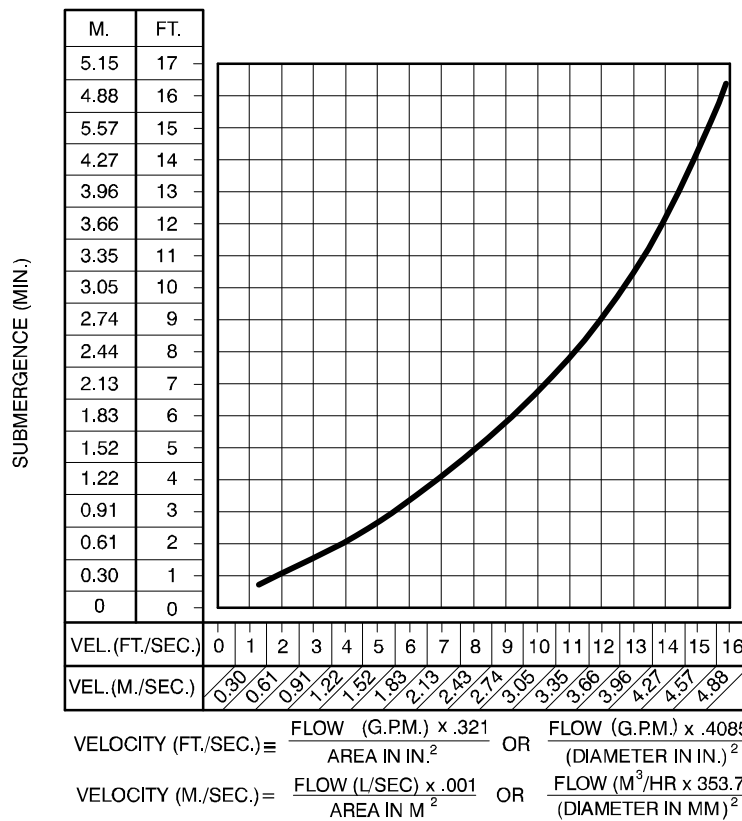


Figure 1. Recommended Minimum Suction Line Submergence vs. Velocity

**DISCHARGE LINES**

**Siphoning**

Do not terminate the discharge line at a level lower than that of the liquid being pumped unless a siphon breaker is used in the line. Otherwise, a siphoning action causing damage to the pump could result.

**Valves**



If the application involves a high discharge head, the discharge throttling valve should close gradually before the pump is stopped.

Due to the high discharge head potential for Ultra V Series pumps, an electronically controlled or automatic slow-closing discharge throttling valve may be required. Consult the factory for additional information on high discharge head applications.

If a throttling valve is desired in the discharge line, use a valve as large as the largest pipe to minimize friction losses. Never install a throttling valve in a suction line.

With high discharge heads, it is recommended that a throttling valve and a system check valve be installed in the discharge line to protect the pump from excessive shock pressure and reverse rotation when it is stopped.

**Bypass Lines**

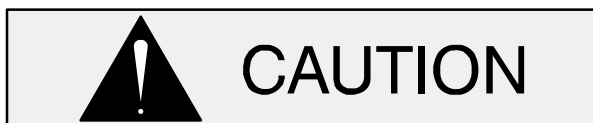
Self-priming pumps are not air compressors. During the priming cycle, air from the suction line must be vented to atmosphere on the discharge side. If the discharge line is open, this air will be vented through the discharge. However, if a check valve has been installed in the discharge line, the discharge side of the pump must be opened to atmospheric pressure through a bypass line installed between the pump discharge and the check valve. A self-priming centrifugal pump **will not prime** if there is sufficient static liquid head to hold the discharge check valve closed.

**NOTE**

*The bypass line should be sized so that it does not*

affect pump discharge capacity; however, the bypass line should be at least 1 inch in diameter to minimize the chance of plugging.

In **low discharge head applications** (less than 30 feet or 9 meters), it is recommended that the bypass line be run back to the wet well, and located 6 inches below the water level or cut-off point of the low level pump. In some installations, this bypass line may be terminated with a six-to-eight foot length of 1-1/4 inch I.D. **smooth-bore** hose; air and liquid vented during the priming process will then agitate the hose and break up any solids, grease, or other substances likely to cause clogging.



A bypass line that is returned to a wet well must be secured against being drawn into the pump suction inlet.

It is also recommended that pipe unions be installed at each 90° elbow in a bypass line to ease disassembly and maintenance.

In **high discharge head applications** (more than 30 feet), an excessive amount of liquid may be bypassed and forced back to the wet well under the full working pressure of the pump; this will reduce overall pumping efficiency. **Therefore, it is recommended that a Gorman-Rupp Automatic Air Release Valve be installed in the bypass line.**

Gorman-Rupp Automatic Air Release Valves are reliable, and require minimum maintenance. See **AUTOMATIC AIR RELEASE VALVE** in this section for information about Gorman-Rupp Automatic Air Release Valves. Consult your Gorman-Rupp distributor, or contact the Gorman-Rupp Company for selection of an Automatic Air Release Valve to fit your application.

If the installation involves a flooded suction such as a below-ground lift station, a pipe union and manual shut-off valve may be installed in the bleed line to allow service of the valve without shutting down the station, and to eliminate the possibility of flooding. If a manual shut-off valve is installed **anywhere** in the air release piping, it **must** be a full-opening **ball type** valve to prevent plugging by solids.



If a manual shut-off valve is installed in a bypass line, it must not be left closed during operation. A closed manual shut-off valve may cause a pump which has lost prime to continue to operate without reaching prime, causing dangerous overheating and possible explosive rupture of the pump casing. Personnel could be severely injured.

Allow an over-heated pump to completely cool before servicing. Do not remove plates, covers, gauges, or fittings from an over-heated pump. Liquid within the pump can reach boiling temperatures, and vapor pressure within the pump can cause parts being disengaged to be ejected with great force. After the pump completely cools, drain the liquid from the pump by removing the casing drain plug. Use caution when removing the plug to prevent injury to personnel from hot liquid.

## AUTOMATIC AIR RELEASE VALVE

When properly installed, a Gorman-Rupp Automatic Air Release Valve will permit air to escape through the bypass line and then close automatically when the pump is fully primed and pumping at full capacity.



**Some leakage (1 to 5 gallons [3.8 to 19 liters] per minute) will occur when the valve is fully closed. Be sure the bypass line is directed back to the wet well or tank to prevent hazardous spills.**

Consult the manual accompanying the Air Release Valve for additional information on valve installation and performance.

**Air Release Valve Installation**

Staged pump applications generate much higher operating pressures within the pump casings than non-staged pump applications. This high pressure could cause a suction check valve to fail, resulting in loss of prime. Therefore, **any pump used in a staged application, whether in the lower or upper position, must have the suction check valve removed.** The lower stage of the VS Series pump is designed without a suction check valve, so removal of the check valve is not required.

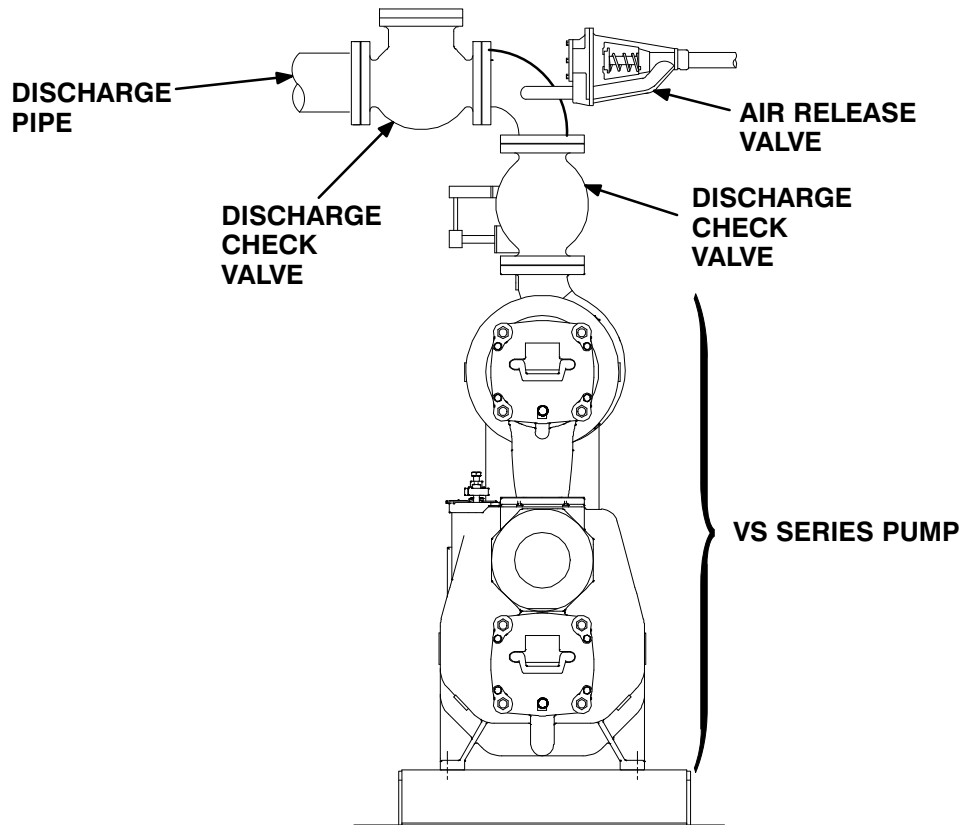
In order to maintain the suction leg and facilitate initial priming (or re-priming if the suction leg is lost) without a suction check valve, it is recommended that staged pump applications be installed using two discharge check valves, with an automatic Air Release Valve installed between the two discharge check valves (see Figure 3). In this manner, when the liquid level in the sump activates the automatic liquid level device and starts the pumps, discharge pressure opens the first discharge check valve, al-

lowing any entrained air in the system to escape through the Air Release Valve. When air in the system is purged, pressure opens the second discharge check valve for full operation.

When the liquid level in the sump lowers enough to de-activate the automatic liquid level device and stop the pumps, the first discharge check valve closes and creates an air-tight seal, thus maintaining liquid in the pump casing and suction line to allow the pump to re-prime when the liquid level in the sump rises and again activates the automatic liquid level device.

The second discharge check valve in the staged application acts as a “shock absorber” to prevent destructive “water hammer” when the pump shuts down.

The Automatic Air Release Valve must be independently mounted in a horizontal position between the discharge check valves. (see Figure 2). The inlet opening in the Air Release Valve is equipped with standard 1-inch NPT pipe threads.



**Figure 2. Typical Automatic Air Release Valve Installation**

**NOTE**

When installing the Air Release Valve on a **staged** pump application, position the Air Release Valve as

close as possible to the primary discharge check valve. Six-inch and larger discharge check valves are available drilled and tapped to receive a stan-

standard 1-inch NPT fitting, or the Air Release Valve may be installed in a spool flange between the two discharge check valves.

Connect the valve outlet to a bleed line which slopes back to the wet well or sump. The bleed line must be the same size as the outlet opening or larger, depending on which Air Release Valve is being used. If **pipng** is used for the bleed line, avoid the use of elbows whenever possible.

**NOTE**

For multiple pump installations, it is recommended that each Air Release Valve be fitted with an independent bleeder line directed back to the wet well. If multiple Air Release Valves are installed in a system, **do not** direct bleeder lines to a common manifold pipe. Contact your Gorman-Rupp distributor or the Gorman-Rupp Company for information about installation of an Automatic Air Release Valve for your specific application.

**DRIVE ARRANGEMENTS**

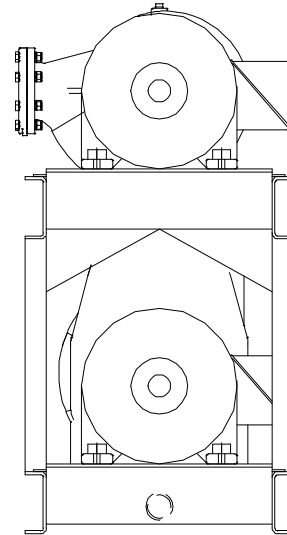
Special consideration must be given to drive arrangements for staged pumping applications. Since pump installations are seldom identical, this section provides some general recommendations for selecting drive arrangements for staged pumps. Consult the factory for information regarding your specific application.

**Dual Motor Drives**

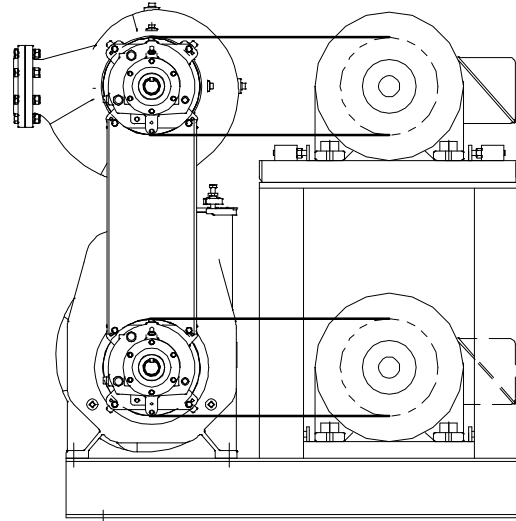
It is recommended that each pump be directly driven by its own electric motor, either through couplings (see Figure 3) or a belt arrangement (see Figure 4).

Each motor should be independently operated through a reduced voltage solid state (RVSS) starter, a variable frequency drive (VFD) or an adjustable speed drive (ASD). In this arrangement, the motor powering the lower stage pump should be programmed to start first and “ramp up” to full condition speed, then the second stage pump motor should start and “ramp up” to full condition speed. Pump motor shutdown should be programmed in reverse order, with the second stage pump motor “ramping down” before shutting off, then the first

stage pump motor “ramping down” and shutting off. This “ramp up” and “ramp down” configuration helps reduce inrush current on startup and destructive “water hammer” on both startup and shut down.



**Figure 3. Recommended Dual Motor Direct Drive Arrangement**

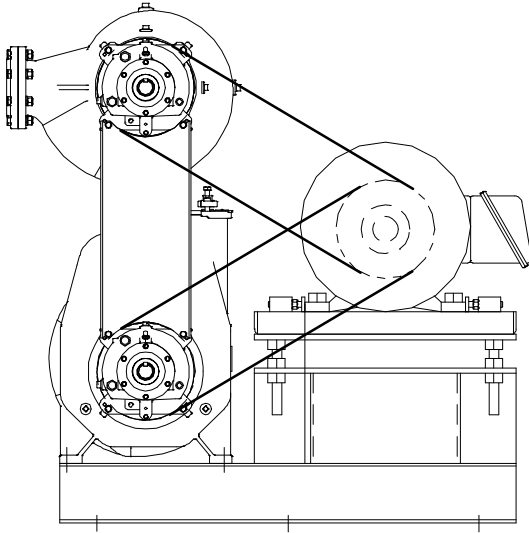


**Figure 4. Recommended Dual Motor Belt Drive Arrangement**

**Single Motor Belt Drives**

In staged applications where both pumps are belt driven by a single motor (either through a synchronous [cog] or V-belt configuration) certain arrangements must be used in order to ensure proper operation.

Figure 5 shows a recommended **alternate single motor belt drive arrangement** where the both pump shafts are driven by separate drive belts connected to one motor. In this arrangement, shaft and/or bearing loads are evenly divided between the two pumps.

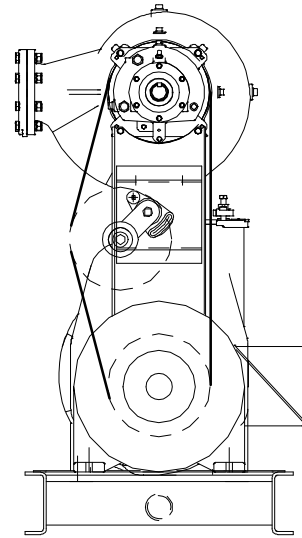


**Figure 5. Alternate Single Motor Belt Drive Arrangement**

**Single Motor Combination Drives**

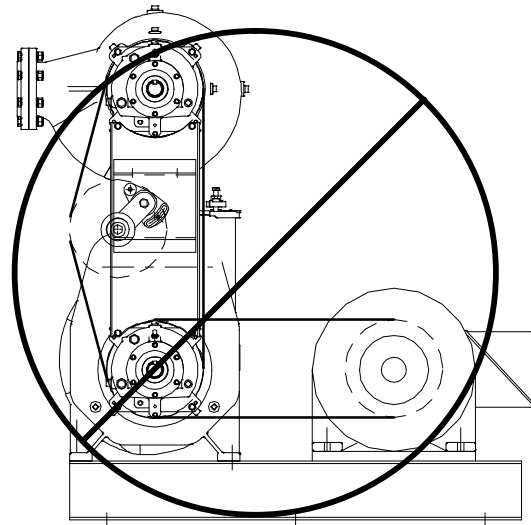
In staged applications where both pumps are driven by a single motor in a combination belt and coupling drive configuration, certain arrangements must be used in order to ensure proper operation.

Figure 6 shows a recommended **alternate single motor combination drive arrangement**, where the first stage pump shaft is direct-coupled to the motor and the second stage pump shaft is driven by belts and an idler located between the two shafts. In this arrangement, shaft and/or bearing loads are shared between the two pumps.

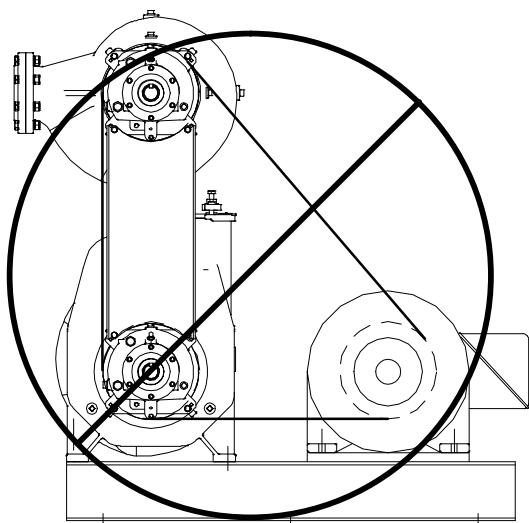


**Figure 6. Alternate Single Motor Combination Drive Arrangement**

Figures 7 and 8 show **single motor belt drive arrangements that are not recommended** because they can cause an overload condition on the shaft and/or bearings, resulting in premature failure.



**Figure 7. Improper Single Motor Belt Drive Arrangement (Dual Belts)**



**Figure 8. Improper Single Motor Belt Drive Arrangement (Single Belt Set)**

**HIGH PUMP TEMPERATURE SHUT-DOWN FOR DUAL-MOTOR DRIVE APPLICATIONS**

**NOTE**

*In dual-motor drive arrangements, the starters for both motors must be interlocked at the control panel to ensure that both motors shut down if overheating of either pump should occur.*

In a dual-motor drive arrangement where each pump is directly driven by its own electric motor, it is recommended that each pump be equipped with a high temperature shutdown sensor and that these sensors be connected in parallel to the pump control panel(s) so that if either sensor is activated, both motors shut down (if powered independently).

It is also recommended that the pump control panel(s) be configured with an alarm system and **manual reset** for the high pump temperature shutdown circuit. In this manner, the cause of overheating must be investigated and corrected before the pumping system can be put back into service.

**ALIGNMENT**

The alignment of the pump and its power source is critical for trouble-free mechanical operation. In

either a flexible coupling or belt-driven system, the driver and pump must be mounted so that their shafts are aligned with and parallel to each other. It is imperative that alignment be checked after the pump and piping are installed, and before operation.

**NOTE**

*Check **Rotation**, Section C, before final alignment of the pump.*

When mounted at the Gorman-Rupp factory, driver and pump are aligned before shipment. Misalignment will occur in transit and handling. Pumps **must** be checked and realigned before operation. Before checking alignment, tighten the foundation bolts. The pump casing feet and/or pedestal feet, and the driver mounting bolts should also be tightly secured.

WARNING!

**When checking alignment, disconnect the power source to ensure that the pump will remain inoperative.**

CAUTION

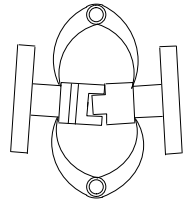
Adjusting the alignment in one direction may alter the alignment in another direction. check each procedure after altering alignment.

**Coupled Drives**

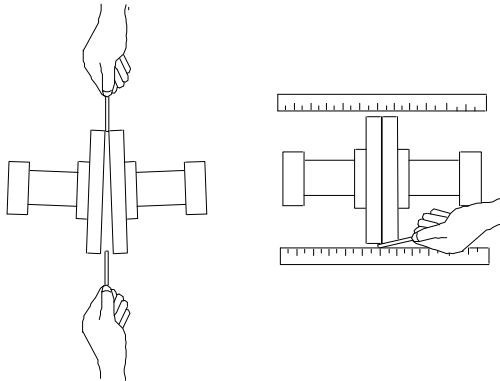
When using couplings, the axis of the power source must be aligned to the axis of the pump shaft in both the horizontal and vertical planes. Most couplings require a specific gap or clearance between the driving and the driven shafts. Refer to the coupling manufacturer's service literature.

Align spider insert type couplings by using calipers to measure the dimensions on the circumference of the outer ends of the coupling hub every 90°. The coupling is in alignment when the hub ends are the same distance apart at all points (see Figure 9).





**Figure 9. Aligning Spider-Type Couplings**



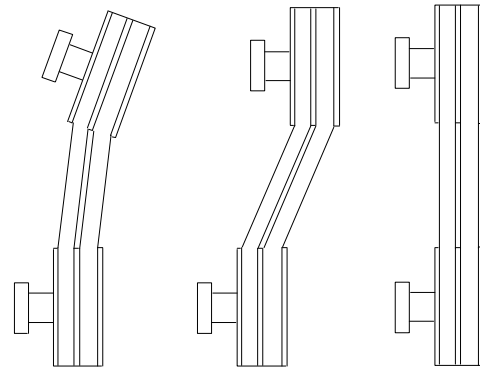
**Figure 10. Aligning Non-Spider Type Couplings**

Align non-spider type couplings by using a feeler gauge or taper gauge between the coupling halves every 90°. The coupling is in alignment when the hubs are the same distance apart at all points (see Figure 10).

Check parallel adjustment by laying a straightedge across both coupling rims at the top, bottom, and side. When the straightedge rests evenly on both halves of the coupling, the coupling is in horizontal parallel alignment. If the coupling is misaligned, use a feeler gauge between the coupling and the straightedge to measure the amount of misalignment.

**Drive Belts**

When using drive belts, the power source and the pump must be parallel. Use a straightedge along the sides of the pulleys to ensure that the pulleys are properly aligned (see Figure 11). In drive systems using two or more belts, make certain that the belts are a matched set; unmatched sets will cause accelerated belt wear.



**MISALIGNED: SHAFTS NOT PARALLEL    MISALIGNED: SHAFTS NOT IN LINE    ALIGNED: SHAFTS PARALLEL AND SHEAVES IN LINE**

**Figure 11. Alignment of V-Belt Driven Pumps**

Tighten the belts in accordance with the belt manufacturer’s instructions. If the belts are too loose, they will slip; if the belts are too tight, there will be excessive power loss and possible bearing failure. Select pulleys that will match the proper speed ratio; overspeeding the pump may damage both pump and power source.



**Do not operate the pump without the guard in place over the rotating parts. exposed rotating parts can catch clothing, fingers, or tools, causing severe injury to personnel.**

**DRIVE BELT TENSIONING**

**General Rules of Tensioning**

For new drive belts, check the tension after 5, 20 and 50 hours of operation and re-tension as required (see the following procedure for measuring belt tension). Thereafter, check and re-tension if required monthly or at 500 hour intervals, whichever comes first.

Ideal drive belt tension is the **lowest** tension at which the belt will not slip under peak load conditions. Do not over-tension drive belts. Over-tensioning will shorten both drive belt and bearing life. Under-tensioning will cause belt slippage. Always keep belts free from dirt, grease, oil and other foreign material which may cause slippage.

## OPERATION – SECTION C

Review all **SAFETY** information in Section A.

Follow the instructions on all tags, labels and decals attached to the pump.



**This pump is designed to handle liquids containing large entrained solids and slurries. Do not attempt to pump volatile, corrosive, or flammable liquids which may damage the pump or endanger personnel as a result of pump failure.**



Pump speed and operating conditions must be within the performance range shown on pages E-1.

### PRIMING

Install the pump and piping as described in **INSTALLATION**. Make sure that the piping connections are tight, and that the pump is securely mounted. Check that the pump is properly lubricated (see **LUBRICATION** in **MAINTENANCE AND REPAIR**).

This pump is self-priming, but the pump should never be operated unless there is liquid in the pump casing.



Never operate this pump unless there is liquid in the pump casing. The pump will not prime when dry. extended operation of a dry pump will destroy the seal assembly.

Add liquid to the pump casing when:

1. The pump is being put into service for the first time.
2. The pump has not been used for a considerable length of time.
3. The liquid in the pump casing has evaporated.

Once the pump casing has been filled, the pump will prime and reprime as necessary.



**After filling the pump casing, reinstall and tighten the fill plug. Do not attempt to operate the pump unless all connecting piping is securely installed. Otherwise, liquid in the pump forced out under pressure could cause injury to personnel.**

To fill the pump, remove the pump casing fill cover or fill plug in the top of the casing, and add clean liquid until the casing is filled. Replace the fill cover or fill plug before operating the pump.

### STARTING

Consult the operations manual furnished with the power source.

#### Rotation

The correct direction of pump rotation is counter-clockwise when facing the impeller. The pump could be damaged and performance adversely affected by incorrect rotation. If pump performance is not within the specified limits (see the curve on pages E-1), check the direction of power source rotation before further troubleshooting.

If an electric motor is used to drive the pump, remove drive belts, couplings, or otherwise disconnect the pump from the motor before checking motor rotation. Operate the motor independently while observing the direction of the motor shaft, or cooling fan.

If rotation is incorrect on a three-phase motor, have a qualified electrician interchange any two of the three phase wires to change direction. If rotation is incorrect on a single-phase motor, consult the literature supplied with the motor for specific instructions.

## OPERATION

### Lines With a Bypass

If a Gorman-Rupp Automatic Air Release Valve has been installed, the valve will automatically open to allow the pump to prime, and automatically close after priming is complete (see **INSTALLATION** for Air Release Valve operation).

If the bypass line is open, air from the suction line will be discharged through the bypass line back to the wet well during the priming cycle. Liquid will then continue to circulate through the bypass line while the pump is in operation.

### Lines Without a Bypass

Open all valves in the discharge line and start the power source. Priming is indicated by a positive reading on the discharge pressure gauge or by a quieter operation. The pump may not prime immediately because the suction line must first fill with liquid. If the pump fails to prime within five minutes, stop it and check the suction line for leaks.

After the pump has been primed, partially close the discharge line throttling valve in order to fill the line slowly and guard against excessive shock pressure which could damage pipe ends, gaskets, sprinkler heads, and any other fixtures connected to the line. When the discharge line is completely filled, adjust the throttling valve to the required flow rate.



**Do not operate the pump against a closed discharge throttling valve for long periods of time. If operated against a closed discharge throttling valve,**

**pump components will deteriorate, and the liquid could come to a boil, build pressure, and cause the pump casing to rupture or explode.**

### Leakage

No leakage should be visible at pump mating surfaces, or at pump connections or fittings. Keep all line connections and fittings tight to maintain maximum pump efficiency.

### Liquid Temperature And Overheating

The **maximum** liquid temperature for this pump is 160°F (71°C). Do not apply it at a higher operating temperature.

Overheating can occur if operated with the valves in the suction or discharge lines closed. Operating against closed valves could bring the liquid to a boil, build pressure, and cause the pump to rupture or explode. If overheating occurs, stop the pump and allow it to cool before servicing it. Refill the pump casing with cool liquid.



**Allow an over-heated pump to completely cool before servicing. Do not remove plates, covers, gauges, or fittings from an over-heated pump. Liquid within the pump can reach boiling temperatures, and vapor pressure within the pump can cause parts being disengaged to be ejected with great force. After the pump completely cools, drain the liquid from the pump by removing the casing drain plug. Use caution when removing the plug to prevent injury to personnel from hot liquid.**

As a safeguard against rupture or explosion due to heat, this pump is equipped with a pressure relief valve which will open if vapor pressure within the pump casing reaches a critical point. If overheating does occur, stop the pump immediately and allow it to cool before servicing it. **Approach any over-**

**heated pump cautiously.** It is recommended that the pressure relief valve assembly be replaced at each overhaul, or any time the pump casing overheats and activates the valve. **Never** replace this valve with a substitute which has not been specified or provided by the Gorman-Rupp Company.

### Strainer Check

If a suction strainer has been shipped with the pump or installed by the user, check the strainer regularly, and clean it as necessary. The strainer should also be checked if pump flow rate begins to drop. If a vacuum suction gauge has been installed, monitor and record the readings regularly to detect strainer blockage.

**Never** introduce air or steam pressure into the pump casing or piping to remove a blockage. This could result in personal injury or damage to the equipment. If backflushing is absolutely necessary, liquid pressure **must** be limited to 50% of the maximum permissible operating pressure shown on the pump performance curve.

### Pump Vacuum Check

With the pump inoperative, install a vacuum gauge in the system, using pipe dope on the threads. Block the suction line and start the pump. At operating speed the pump should pull a vacuum of 20 inches (508,0 mm) or more of mercury. If it does not, check for air leaks in the seal, gasket, or discharge valve.

Open the suction line, and read the vacuum gauge with the pump primed and at operation speed. Shut off the pump. The vacuum gauge reading will immediately drop proportionate to static suction lift, and should then stabilize. If the vacuum reading falls off rapidly after stabilization, an air leak exists. Before checking for the source of the leak, check the point of installation of the vacuum gauge.

## STOPPING

Never halt the flow of liquid suddenly. If the liquid being pumped is stopped abruptly, damaging

shock waves can be transmitted to the pump and piping system. Close all connecting valves slowly.



If the application involves a high discharge head, gradually close the discharge throttling valve before stopping the pump.

After stopping the pump, lock out or disconnect the power source to ensure that the pump will remain inoperative.



**Do not operate the pump against a closed discharge throttling valve for long periods of time. If operated against a closed discharge throttling valve, pump components will deteriorate, and the liquid could come to a boil, build pressure, and cause the pump casing to rupture or explode.**

### Cold Weather Preservation

In below freezing conditions, drain the pump to prevent damage from freezing. Also, clean out any solids by flushing with a hose. Operate the pump for approximately one minute; this will remove any remaining liquid that could freeze the pump rotating parts. If the pump will be idle for more than a few hours, or if it has been pumping liquids containing a large amount of solids, drain the pump, and flush it thoroughly with clean water. To prevent large solids from clogging the drain port and preventing the pump from completely draining, insert a rod or stiff wire in the drain port, and agitate the liquid during the draining process. Clean out any remaining solids by flushing with a hose.

## BEARING TEMPERATURE CHECK

Bearings normally run at higher than ambient temperatures because of heat generated by friction. Temperatures up to 160°F (71°C) are considered normal for bearings, and they can operate safely to at least 180°F (82°C).

Checking bearing temperatures by hand is inaccurate. Bearing temperatures can be measured accurately by placing a contact-type thermometer against the housing. Record this temperature for future reference.

A sudden increase in bearing temperature is a warning that the bearings are at the point of failing to operate properly. Make certain that the bearing lubricant is of the proper viscosity and at the cor-

rect level (see **LUBRICATION** in **MAINTENANCE AND REPAIR**). Bearing overheating can also be caused by shaft misalignment and/or excessive vibration.

When pumps are first started, the bearings may seem to run at temperatures above normal. Continued operation should bring the temperatures down to normal levels.

## TROUBLESHOOTING – SECTION D

Review all **SAFETY** information in Section A.



**Before attempting to open or service the pump:**

1. Familiarize yourself with this manual.
2. Lock out or disconnect the power source to ensure that the pump will remain inoperative.
3. Allow the pump to completely cool if overheated.
4. Check the temperature before opening any covers, plates, or plugs.
5. Close the suction and discharge valves.
6. Vent the pump slowly and cautiously.
7. Drain the pump.

TROUBLE	POSSIBLE CAUSE	PROBABLE REMEDY
PUMP FAILS TO PRIME	Not enough liquid in casing.  Suction check valve contaminated or damaged.  Air leak in suction line.  Lining of suction hose collapsed.  Leaking or worn seal or pump gasket.  Suction lift or discharge head too high.  Strainer clogged.	Add liquid to casing. See <b>PRIMING</b> .  Clean or replace check valve.  Correct leak.  Replace suction hose.  Check pump vacuum. Replace leaking or worn seal or gasket.  Check piping installation and install bypass line if needed. See <b>INSTALLATION</b> .  Check strainer and clean if necessary.
PUMP STOPS OR FAILS TO DELIVER RATED FLOW OR PRESSURE	Air leak in suction line.  Lining of suction hose collapsed.  Leaking or worn seal or pump gasket.	Correct leak.  Replace suction hose.  Check pump vacuum. Replace leaking or worn seal or gasket.

TROUBLE	POSSIBLE CAUSE	PROBABLE REMEDY
<p>PUMP STOPS OR FAILS TO DELIVER RATED FLOW OR PRESSURE</p>	<p>Strainer clogged.</p> <p>Suction intake not submerged at proper level or sump too small.</p> <p>Impeller or other wearing parts worn or damaged.</p> <p>Impeller clogged.</p> <p>Pump speed too slow.</p> <p>Discharge head too high.</p> <p>Suction lift too high.</p>	<p>Check strainer and clean if necessary.</p> <p>Check installation and correct submergence as needed.</p> <p>Replace worn or damaged parts. Check that impeller is properly centered and rotates freely.</p> <p>Free impeller of debris.</p> <p>Check driver output; check belts or couplings for slippage.</p> <p>Install bypass line.</p> <p>Measure lift w/vacuum gauge. Reduce lift and/or friction losses in suction line.</p>
<p>PUMP REQUIRES TOO MUCH POWER</p>	<p>Pump speed too high.</p> <p>Discharge head too low.</p> <p>Liquid solution too thick.</p> <p>Bearing(s) frozen.</p>	<p>Check driver output; check that sheaves or couplings are correctly sized.</p> <p>Adjust discharge valve.</p> <p>Dilute if possible.</p> <p>Disassemble pump and check bearing(s).</p>
<p>PUMP CLOGS FREQUENTLY</p>	<p>Liquid solution too thick.</p> <p>Discharge flow too slow.</p> <p>Suction check valve or foot valve clogged or binding.</p>	<p>Dilute if possible.</p> <p>Open discharge valve fully to increase flow rate, and run power source at maximum governed speed.</p> <p>Clean valve.</p>
<p>EXCESSIVE NOISE</p>	<p>Cavitation in pump.</p> <p>Pumping entrained air.</p> <p>Pump or drive not securely mounted.</p> <p>Impeller clogged or damaged.</p>	<p>Reduce suction lift and/or friction losses in suction line. Record vacuum and pressure gauge readings and consult local representative or factory.</p> <p>Locate and eliminate source of air bubble.</p> <p>Secure mounting hardware.</p> <p>Clean out debris; replace damaged parts.</p>

### PREVENTIVE MAINTENANCE

Routine preventive maintenance of the pump will maintain peak operating performance. Since pump applications are seldom identical, and pump wear is directly affected by such things as the abrasive qualities, pressure and temperature of the liquid being pumped, this section is intended only to provide general recommendations and practices for preventive maintenance. Regardless of the application however, following a routine preventive maintenance schedule will help assure trouble-free performance and long life from your Gorman-Rupp pump.

Record keeping is an essential component of a good preventive maintenance program. Changes

in suction and discharge gauge readings (if so equipped) between regularly scheduled inspections can indicate problems that can be corrected before system damage or catastrophic failure occurs. The appearance of wearing parts should also be documented at each inspection for comparison as well. Also, if records indicate that a certain part (such as the seal) fails at approximately the same duty cycle, the part can be checked and replaced before failure occurs, reducing unscheduled down time.

For new applications, a first inspection of wearing parts at 250 hours will give insight into the wear rate for your particular application. Subsequent inspections should be performed at the intervals shown on the chart below. Critical applications should be inspected more frequently.

<b>Preventive Maintenance Schedule</b>					
<b>Item</b>	<b>Service Interval*</b>				
	<b>Daily</b>	<b>Weekly</b>	<b>Monthly</b>	<b>Semi-Annually</b>	<b>Annually</b>
General Condition (Temperature, Unusual Noises or Vibrations, Cracks, Leaks, Loose Hardware, Etc.)	I				
Pump Performance (Gauges, Speed, Flow)	I				
Bearing Lubrication		I			R
Seal Lubrication (And Packing Adjustment, If So Equipped)		I			R
V-Belts (If So Equipped)			I		
Air Release Valve Plunger Rod (If So Equipped)			I	C	
Front Impeller Clearance (Wear Plate)				I	
Rear Impeller Clearance (Seal Plate)				I	
Check Valve					I
Pressure Relief Valve (If So Equipped)					C
Pump and Driver Alignment					I
Shaft Deflection					I
Bearings					I
Bearing Housing					I
Piping					I
Driver Lubrication – See Mfgr’s Literature					I

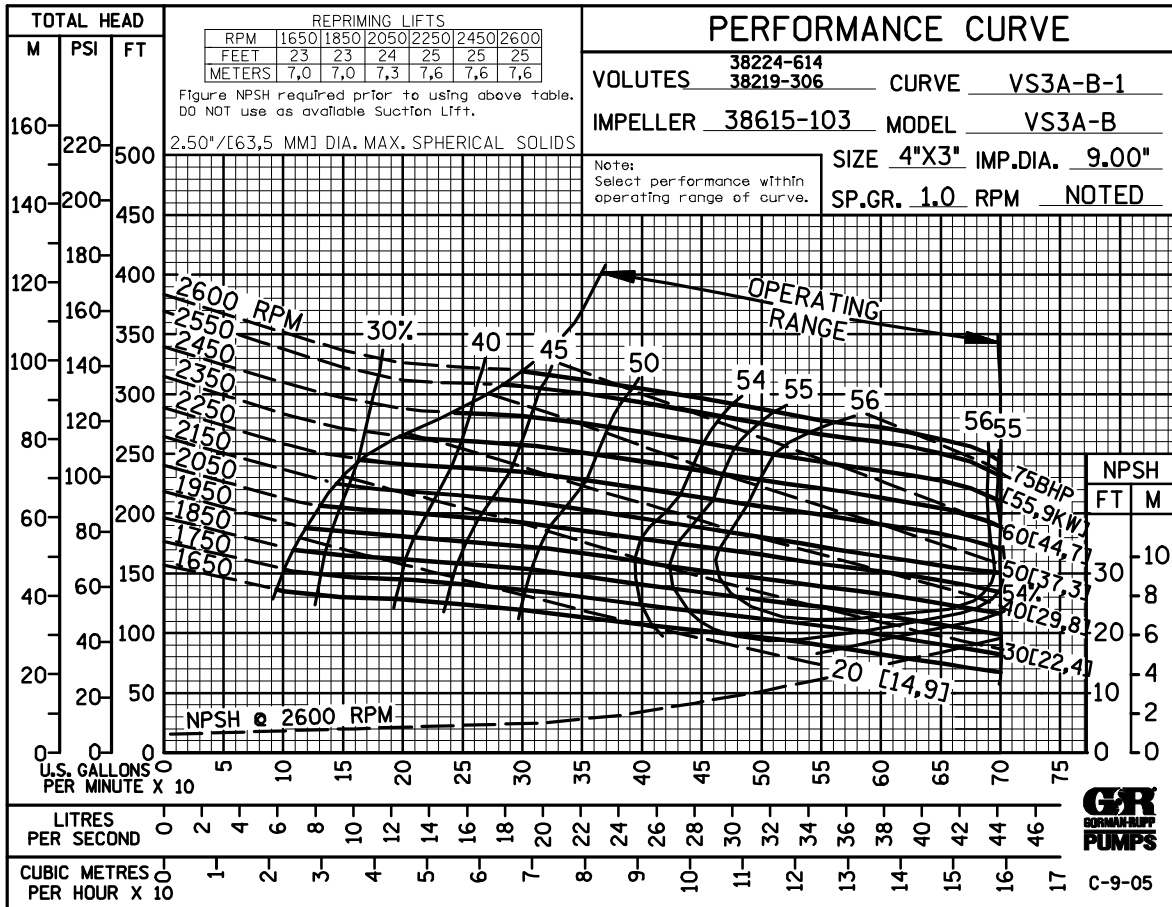
**Legend:**  
 I = Inspect, Clean, Adjust, Repair or Replace as Necessary  
 C = Clean  
 R = Replace

\* Service interval based on an intermittent duty cycle equal to approximately 4000 hours annually. Adjust schedule as required for lower or higher duty cycles or extreme operating conditions.



## PUMP MAINTENANCE AND REPAIR – SECTION E

**MAINTENANCE AND REPAIR OF THE WEARING PARTS OF THE PUMP WILL MAINTAIN PEAK OPERATING PERFORMANCE.**



**STANDARD PERFORMANCE FOR PUMP MODEL VS3A60-B, Including /WW**

\*Based on 70°F (21°C) clear water at sea level with minimum suction lift. Since pump installations are seldom identical, your performance may be different due to such factors as viscosity, specific gravity, elevation, temperature, and impeller trim.

If your pump serial number is followed by an "N", your pump is **NOT** a standard production model. Contact the Gorman-Rupp Company to verify performance or part numbers.



Pump speed and operating condition points must be within the continuous performance range shown on the curves.

**NOTE**

*The horsepower shown in the above curve is total combined horsepower for both the first and second stage of the VS Model.*

SECTION DRAWING

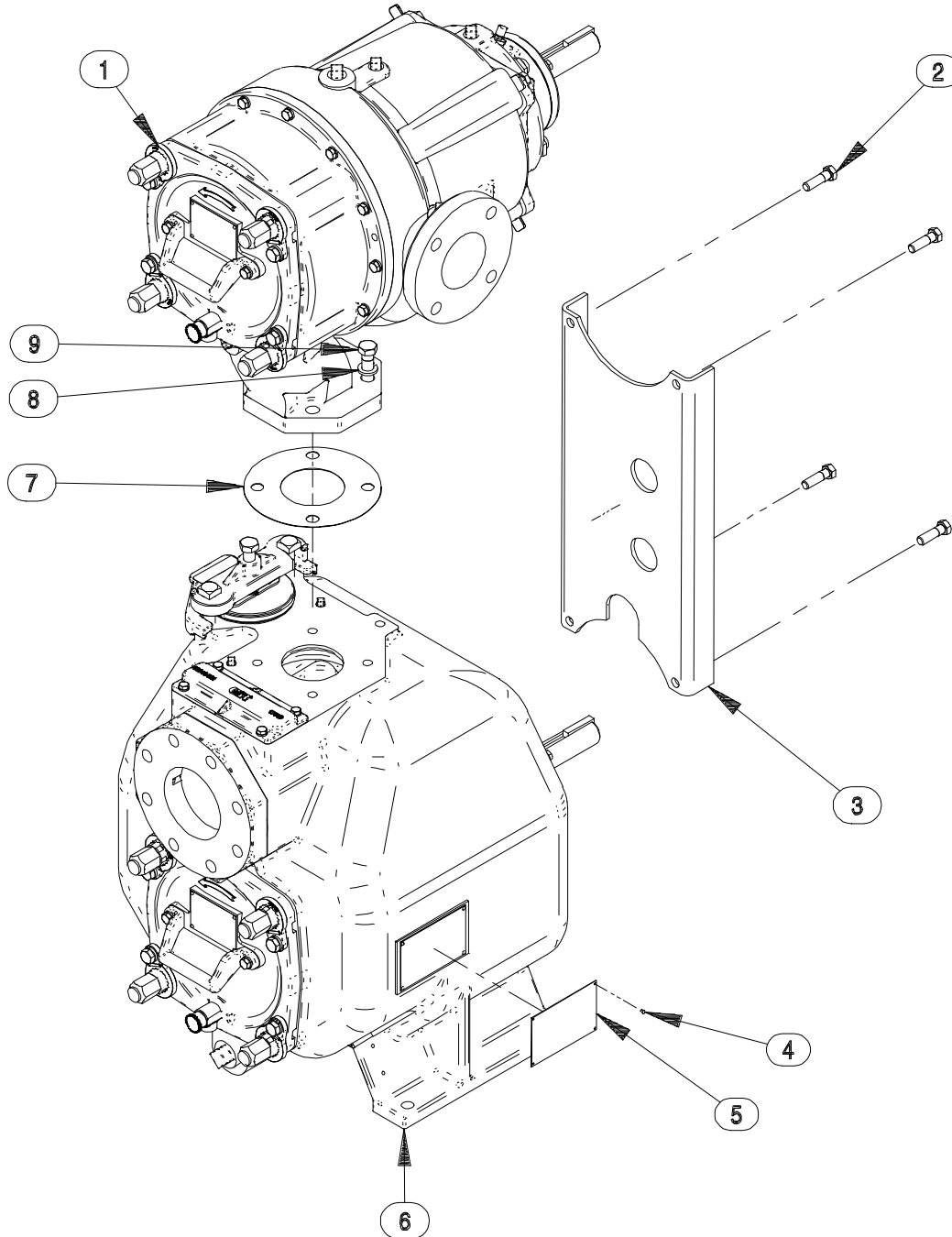


Figure 1. Pump Model VS3A60-B (Including /WW)

**PARTS LIST**  
**Pump Model VS3A60-B (Including /WW)**  
 (From S/N 1321968 Up)

If your pump serial number is followed by an "N", your pump is **NOT** a standard production model. Contact the Gorman-Rupp Company to verify part numbers.

ITEM NO.	PART NAME	PART NUMBER	MAT'L CODE	QTY	ITEM NO.	PART NAME	PART NUMBER	MAT'L CODE	QTY
1	ULTRA MATE PUMP ASSY	46146-010	----	1		PRIMING STICKER	6588AH	----	1
2	HEX HD CAPSCREW	B0807	15991	4		SUCTION STICKER	6588AG	----	1
3	SUPPORT BRACE	41881-875	24150	1		INSTRUCTION TAG	38817-011	----	1
4	DRIVE SCREW	BM#04-03	17000	4					
5	NAME PLATE	38818-149	13000	1		OPTIONAL:			
6	PUMP ASSEMBLY					STAGED FLANGE KITS:			
	VS3A60-B	46146-037	----	1		-4" X 3" NPT	48213-122	----	1
	VS3A60-B /WW	46146-038	----	1		-4" X 3" ASA SPOOL	48213-123	----	1
7 *	DISCHARGE GASKET	25113-033	----	1		-4" X 3" METRIC SPOOL	48213-124	----	1
8	LOCK WASHER	J10	15991	4		HI TEMP SHUT-DOWN KITS:			
9	HEX HD CAPSCREW	B1007	15991	4		-145°F	48313-186	----	1
NOT SHOWN:						-130°F	48313-256	----	1
	LUBRICATION DECAL	38817-084	----	1		-120°F	48313-257	----	1
	G-R DECAL	GR-03	----	1		HIGH TEMP SHUT-DOWN			
	"ULTRA V" DECAL	38816-342	----	1		THERMOSTAT KIT 145°F	48313-172	----	1
	ROTATION DECAL	2613M	----	1		AIR RELEASE VALVES:			
	INSTRUCTION TAG	38817-023	----	1		-10# COMP SPRING	GRP33-07A	----	1
	WARNING DECAL	2613FE	----	1		-25# COMP SPRING	GRP33-07	----	1
	DISCHARGE STICKER	6588BJ	----	1		-80# COMP SPRING	GRP33-07B	----	1

\* INDICATES PARTS RECOMMENDED FOR STOCK

SECTION DRAWING

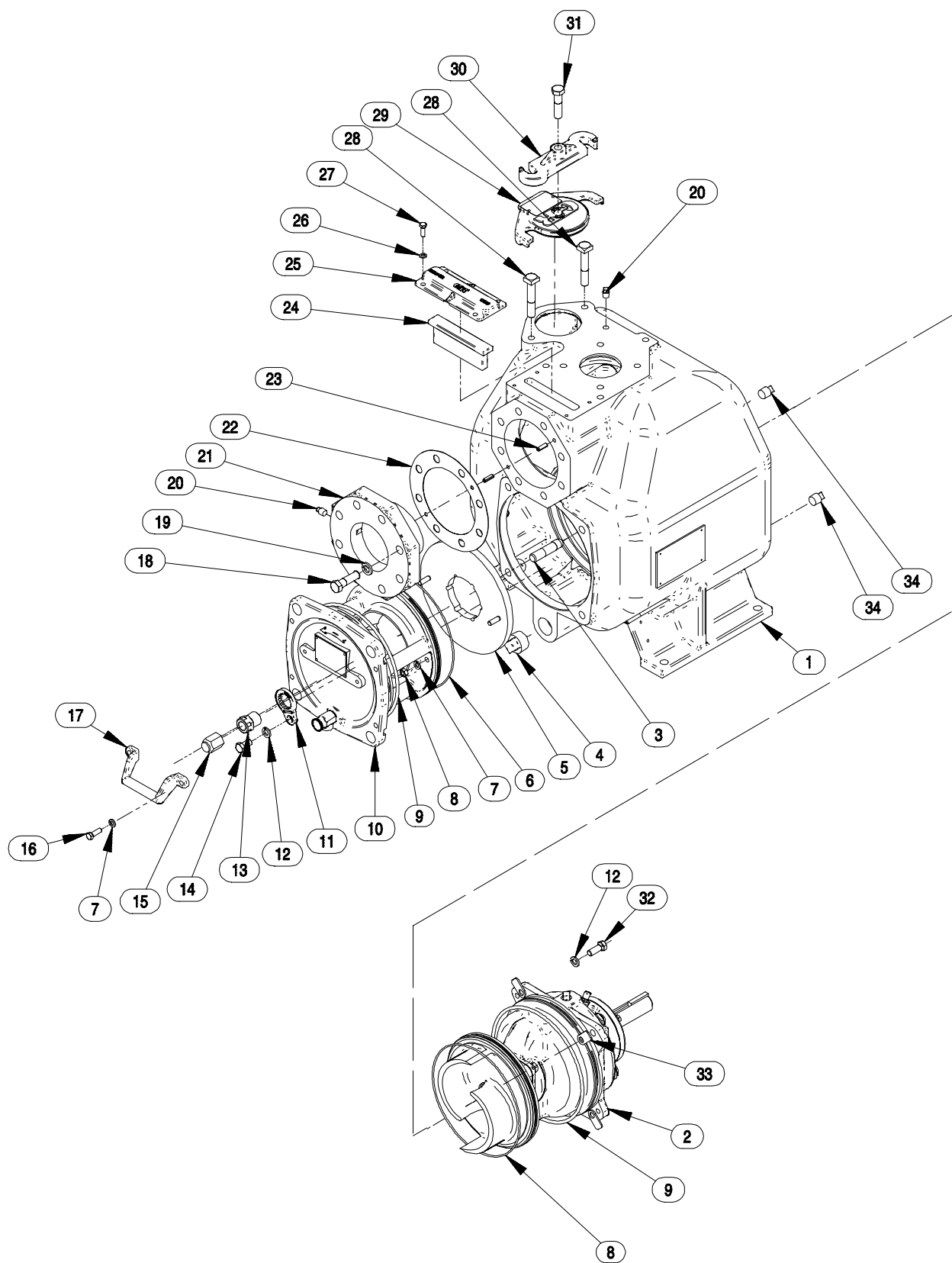


Figure 2. Pump Assemblies 46146-037 and 46146-038

**PARTS LIST**  
**Pump Assemblies 46146-037 and 46146-038**

ITEM NO.	PART NAME	PART NUMBER	MAT'L CODE	QTY	ITEM NO.	PART NAME	PART NUMBER	MAT'L CODE	QTY
1	PUMP CASING	38224-614	10000	1	30	CLAMP BAR	38111-004	11010	1
2	REPAIR ROTATING ASSY				31	HEX HD CAPSCREW	B1010S	15991	1
	VS3A60-B	44163-463	----	1	32	HEX HD CAPSCREW	B0806	15991	4
	VS3A60-B /WW	44163-464	----	1	33	SPACER	33221-022	17040	4
3	STUD	C1213	1500G	4	34	PIPE PLUG	P08	15079	2
4	PIPE PLUG	P20	10009	1	NOT SHOWN:				
5 *	WEAR PLATE ASSY	46451-758	24150	1	SUCTION SPOOL PARTS (VS3A60-B /WW ONLY)				
6 *	O-RING	25152-273	----	1		-SPOOL FLANGE	12066A	10010	1
7	LOCK WASHER	J06	15991	4		-FLANGE GASKET	25113-034	----	1
8	HEX NUT	D06	15991	4		-FLANGE PIPE PLUG	P20	10009	1
9 *	O-RING	S1674	----	2	OPTIONAL:				
10	COVER PLATE ASSY	42111-831	----	1		DISASSEMBLY TOOL	48711-020	----	1
	-WARNING PLATE	2613EV	13990	1		FLANGE KITS:			
	-DRIVE SCREW	BM#04-03	17000	4		3" NPT DISCH KIT	48213-119	----	1
	* -PRESS RELIEF VALVE	26662-007	----	1		4" X 3" ASA SUCTION/DISCHARGE			
	-WARNING DECAL	38816-302	----	1		SPOOL KIT	48213-143	----	1
11	LOCK COLLAR	38115-551	15001	4		-4" ASA SUCTION			
12	LOCK WASHER	J08	15991	8		SPOOL KIT	48213-142	----	1
13	ADJUSTING SCREW	31871-070	1500G	4		-3" ASA DISCHARGE			
14	HEX HD CAPSCREW	B0804	15991	4		SPOOL KIT	48213-120	----	1
15	BACK COVER NUT	31871-073	15000	4		4" X 3" METRIC SUCTION/DISCHARGE			
16	HEX HD CAPSCREW	B0604-1/2	15991	2		SPOOL KIT	48213-121	----	1
17	HANDLE	12354	13010	1		-4" METRIC SUCTION			
18	HEX HD CAPSCREW					SPOOL KIT	48213-144	----	1
	VS3A60-B	B1009	15991	8		-3" METRIC DISCHARGE			
	VS3A60-B /WW	B1013	15991	8		SPOOL KIT	48213-145	----	1
19	LOCK WASHER	J10	15991	8		G-R HARD IRON PARTS:			
20	PIPE PLUG	P04	15079	3		-WEAR PLATE ASSY	46451-758	24150	1
21	NPT SUCT FLG/MLV SEAT	38641-534	10000	1		SST PARTS:			
22 *	GASKET	38683-502	19370	1		-WEAR PLATE ASSY	46451-758	24170	1
23	ROLL PIN	21154-229	----	2		HI TEMP SHUT-DOWN KITS:			
24	FLAP VALVE PLUG	38349-416	19020	1		-145°F	48313-186	----	1
25	FLAP VALVE COVER	38346-621	17040	1		-130°F	48313-256	----	1
26	LOCK WASHER	J05	15991	4		-120°F	48313-257	----	1
27	HEX HD CAPSCREW	B0504	15991	6		HIGH TEMP SHUT-DOWN			
28	SQUARE HD BOLT	A1014	15991	2		THERMOSTAT KIT 145°F	48313-172	----	1
29	FILL PORT COVER ASSY	42111-437	----	1		AIR RELEASE VALVES:			
	* -FILL PORT GASKET	50G	19210	1		-10# COMP SPRING	GRP33-07A	----	1
	-WARNING PLATE	38816-097	13990	1		-25# COMP SPRING	GRP33-07	----	1
	-DRIVE SCREW	BM#04-03	17000	2		-80# COMP SPRING	GRP33-07B	----	1

\* INDICATES PARTS RECOMMENDED FOR STOCK

SECTION DRAWING

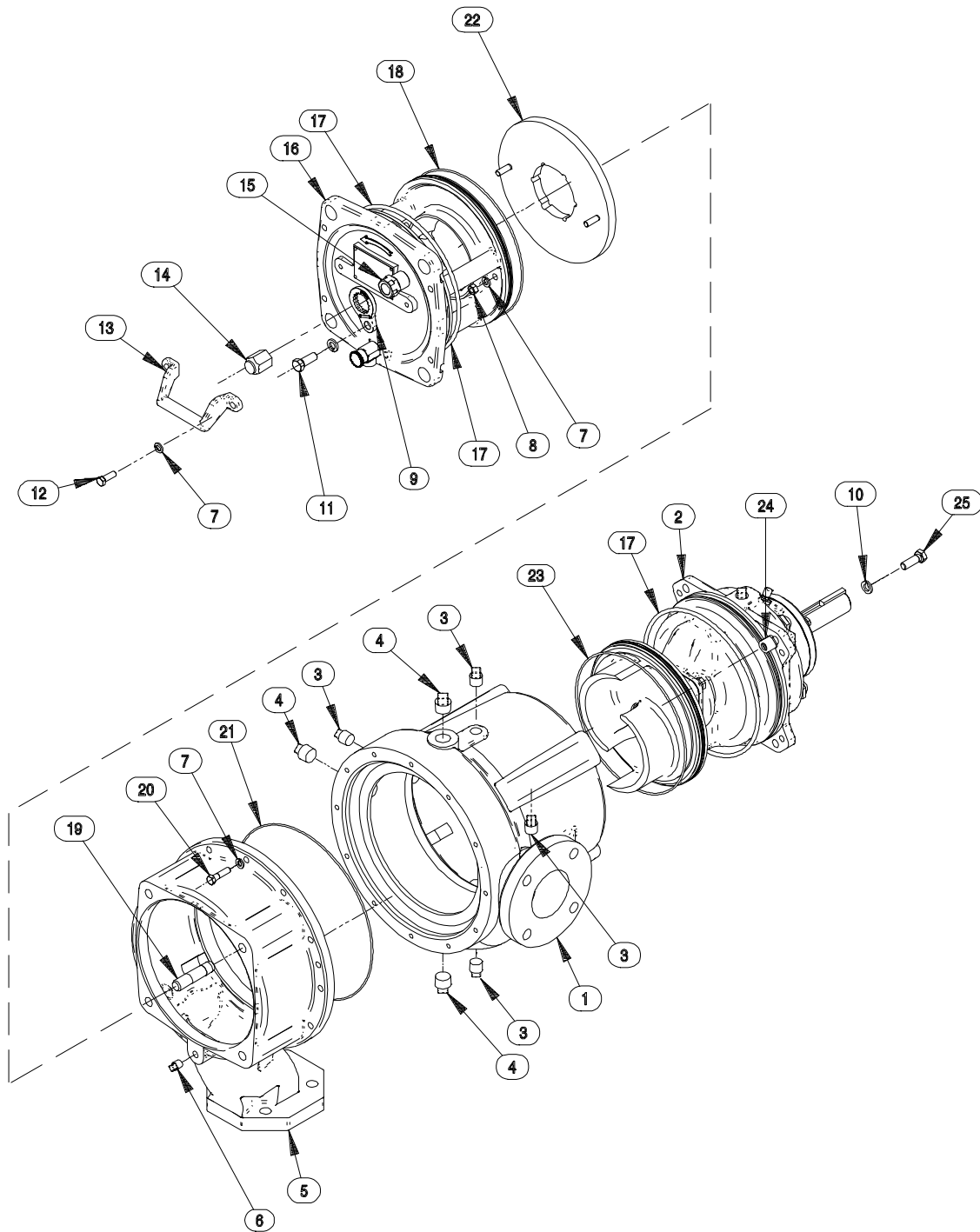


Figure 3. 46146-010 Ultra Mate Pump Assembly

**PARTS LIST**  
**46146-010 Ultra Mate Pump Assembly**

If your pump serial number is followed by an "N", your pump is **NOT** a standard production model. Contact the Gorman-Rupp Company to verify part numbers.

ITEM NO.	PART NAME	PART NUMBER	MAT'L CODE	QTY	ITEM NO.	PART NAME	PART NUMBER	MAT'L CODE	QTY
1	PUMP CASING	38219-306	10000	1	19	STUD	C1213	15991	4
2	REPAIR ROTATING ASSY				20	HEX HD CAPSCREW	B0606	15991	11
	VS3A60-B	44163-463	----	1	21	* O-RING	25152-277	----	1
	VS3A60-B /WW	44163-464	----	1	22	* WEAR PLATE ASSY	46451-758	24150	1
3	PIPE PLUG	P08	15079	4	23	* O-RING	25152-273	----	1
4	PIPE PLUG	P12	15079	3	24	SPACER	33221-022	17040	4
5	TRANSITION CHAMBER	38644-805	11010	1	25	HEX HD CAPSCREW	B0806	15991	4
6	PIPE PLUG	P04	15079	1	OPTIONAL:				
7	LOCK WASHER	J06	15991	15		DISASSEMBLY TOOL	48711-020	----	1
8	HEX NUT	D06	15991	2		G-R HARD IRON PARTS:			
9	LOCK COLLAR	38115-551	23030	4		-WEAR PLATE ASSY	46451-758	24150	1
10	LOCK WASHER	J08	15991	8		SST PARTS:			
11	HEX HD CAPSCREW	B0804	15991	4		-WEAR PLATE ASSY	46451-758	24170	1
12	HEX HD CAPSCREW	B0604-1/2	15991	2		HI TEMP SHUT-DOWN KITS:			
13	HANDLE	12354	13010	1		-145°F	48313-186	----	1
14	BACK COVER NUT	31871-073	15000	4		-130°F	48313-256	----	1
15	ADJUSTING SCREW	31871-070	1500G	4		-120°F	48313-257	----	1
16	COVER PLATE ASSY	42111-831	----	1		HIGH TEMP SHUT-DOWN			
	-WARNING PLATE	2613EV	13990	1		THERMOSTAT KIT 145°F	48313-172	----	1
	-DRIVE SCREW	BM#04-03	17000	4		AIR RELEASE VALVES:			
	* -PRESS RELIEF VALVE	26662-007	----	1		-10# COMP SPRING	GRP33-07A	----	1
	-WARNING DECAL	38816-302	----	1		-25# COMP SPRING	GRP33-07	----	1
17	* O-RING	S1674	----	2		-80# COMP SPRING	GRP33-07B	----	1
18	* O-RING	25152-273	----	1					

\* INDICATES PARTS RECOMMENDED FOR STOCK

SECTION DRAWING

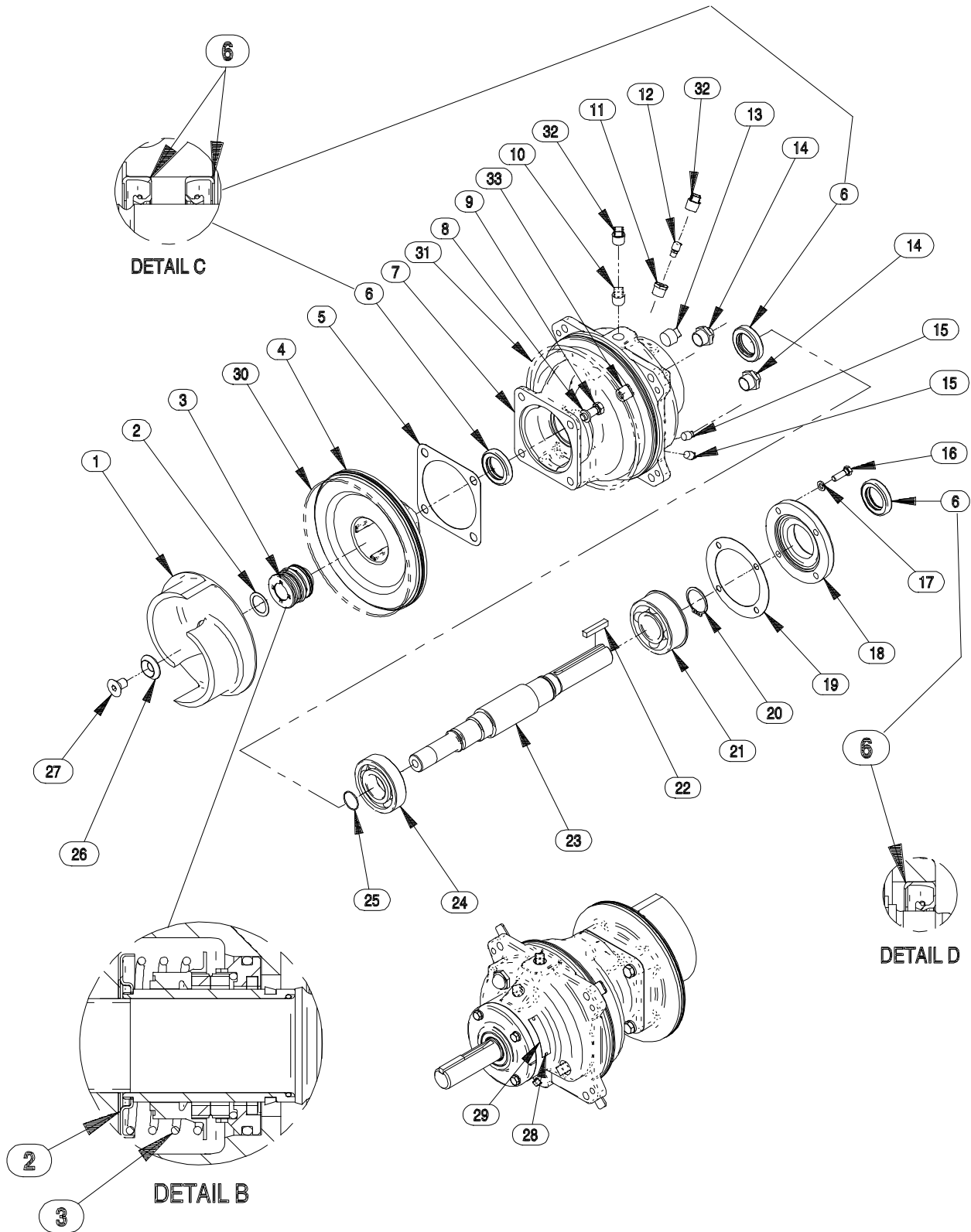


Figure 4. Repair Rotating Assemblies



**PARTS LIST**  
**Repair Rotating Assemblies**

**Note:** Order the complete Repair Rotating Assembly from the Pump Model Assembly Parts Lists on pages E-2 or E-3. Rotating Assemblies for /WW models also include all standard parts listed below.

ITEM NO.	PART NAME	PART NUMBER	MAT'L CODE	QTY	ITEM NO.	PART NAME	PART NUMBER	MAT'L CODE	QTY
1 *	IMPELLER	38615-103	11010	1	24 *	BALL BEARING	S1088	----	1
2 *	IMP ADJ SHIM SET	37J	17090	1	25 *	O-RING	25154-022	----	REF
3 *	CARTRIDGE SEAL ASSY	46513-151	----	1	26 *	IMPELLER WASHER	31167-029	16000	1
4	SEAL PLATE	38272-267	10000	1	27 *	IMPELLER SCREW	F1004S	1500G	1
5 *	GASKET	10959G	20000	1	28	DRIVE SCREW	BM#04-03	17000	2
6 *	OIL SEAL	S1352	----	3	29	S/N PLATE	2613GG	13990	1
7	BEARING HOUSING	38251-411	10000	1	30 *	O-RING	25152-273	----	1
8	LOCK WASHER	J08	15991	4	31 *	O-RING	S1674	----	1
9	HEX HD CAPSCREW	B0805-1/2	15991	4	32	SHIPPING PLUG	11495B	15079	2
10	VENTED PIPE PLUG	4823A	15079	1	33	SPACER	33221-022	17040	4
11	RED PIPE BUSHING	AP0802	15079	1	NOT SHOWN:				
12	AIR VENT	S1530	----	1		INSTRUCTION TAG	6588U	----	1
13	PIPE PLUG	P12	15079	1		ROTATION DECAL	2613M	----	1
14	SIGHT GAUGE	S1471	----	2		PIPE PLUG	PC20	10009	1
15	PIPE PLUG	P04	15079	2	OPTIONAL:				
16	HEX HD CAPSCREW	B0605	----	4	G-R HARD IRON PARTS:				
17	LOCK WASHER	J06	15991	4		-IMPELLER	38615-103	1102H	1
18	BEARING CAP	38322-220	10000	1		-SEAL PLATE	38272-267	1102H	1
19 *	GASKET	38683-271	----	1	SST PARTS:				
20	RETAINING RING	S442	----	1		-IMPELLER	38615-103	17070	1
21 *	BALL BEARING	S375	----	1		-SEAL PLATE	38272-267	17070	1
22 *	SHAFT KEY	N0608	15990	1		-IMPELLER SHAFT	38514-827	1706H	1
23 *	IMPELLER SHAFT	38514-827	1706H	1		-CART SEAL ASSY	46513-156	----	1

\* INDICATES PARTS RECOMMENDED FOR STOCK

## PUMP AND SEAL DISASSEMBLY AND REASSEMBLY

Review all SAFETY information in Section A.

Follow the instructions on all tags, label and decals attached to the pump.

This pump requires little service due to its rugged, minimum-maintenance design. However, if it becomes necessary to inspect or replace the wearing parts, follow these instructions which are keyed to the sectional views (see Figures 1, 2, 3 and 4) and the accompanying parts lists.

This manual will alert personnel to known procedures which require special attention, to those which could damage equipment, and to those which could be dangerous to personnel. However, this manual cannot possibly anticipate and provide detailed precautions for every situation that might occur during maintenance of the unit. Therefore, it is the responsibility of the owner/maintenance personnel to ensure that **only** safe, established maintenance procedures are used, and that any procedures not addressed in this manual are performed **only** after establishing that neither personal safety nor pump integrity are compromised by such practices.

Many service functions may be performed by draining the pump and removing the back cover assembly. If major repair is required, the piping and/or power source must be disconnected. The following instructions assume complete disassembly is required.

Before attempting to service the pump, disconnect or lock out the power source and take precautions to ensure that it will remain inoperative. Close all valves in the suction and discharge lines.

For power source disassembly and repair, consult the literature supplied with the power source, or contact your local power source representative.



Before attempting to open or service the pump:

1. Familiarize yourself with this manual.
2. Disconnect or lock out the power source to ensure that the pump will remain inoperative.
3. Allow the pump to completely cool if overheated.
4. Check the temperature before opening any covers, plates, or plugs.
5. Close the suction and discharge valves.
6. Vent the pump slowly and cautiously.
7. Drain the pump.



Use lifting and moving equipment in good repair and with adequate capacity to prevent injuries to personnel or damage to equipment.



**Do not install a suction check valve in the first stage of the VS Series pump model. Installing a suction check valve in the first stage of the VS Series pump model can cause over-pressurization of the first stage pump casing, resulting in possible explosion of the pump and serious injury or death to personnel.**

### NOTE

*The back cover and rotating assemblies are identical for both the first stage pump and the Ultra Mate second stage, therefore the service instructions are the same. Because of these similarities, most of the following instructions reference the first stage*

pump model drawing (Figure 2). Instructions specific to the Ultra Mate second stage will reference Figures 1 and/or 3 and will denote “Ultra Mate Second Stage Only”.

**Support Plate Removal**

**(Figure 1)**

Disassembly of the either the first or second stage pump model requires removal of the support plate (3). Disengage the hardware (28) and remove the plate.

**Back Cover And Wear Plate Removal**

**(Figure 2)**

The wear plate (5) is easily accessible and may be serviced by removing the back cover assembly (10). Before attempting to service the pump, remove the pump casing drain plug (4) and drain the pump. Clean and reinstall the drain plug.

Remove the back cover nuts (15) and pry the back cover and assembled wear plate from the pump casing (1).

**NOTE**

An alternate method of removing the back cover from the pump casing is to remove the back cover nuts (17) and two diagonally opposing locking collars (13). Install two 1/2–16 UNC x 2 inch long screws in the tapped holes in the back cover and use them to press the back cover out of the pump casing.

Inspect the wear plate, and replace it if badly scored or worn. To remove the wear plate, disengage the hardware (7 and 8).

Inspect the back cover O-rings (6 and 9) and replace it if damaged or worn.

**Rotating Assembly Removal**

**(Figure 4)**

The rotating assembly may be serviced without disconnecting the suction or discharge piping;

however, the power source must be removed to provide clearance.

The impeller (1) should be loosened while the rotating assembly is still secured to the pump casing. Before loosening the impeller, remove the seal cavity drain plug and drain the seal lubricant. This will prevent the oil in the seal cavity from escaping when the impeller is loosened. Clean and reinstall the seal cavity drain plug.

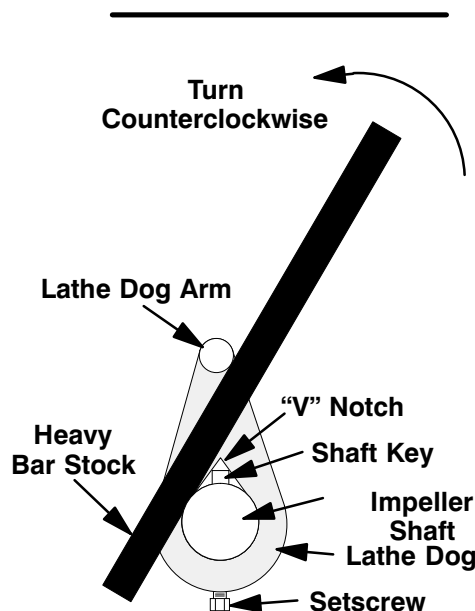
Immobilize the impeller by wedging a block wood between the vanes and the pump casing. Remove the impeller capscrew and washer (26 and 27).

If removed, install the shaft key (22). Install a lathe dog on the drive end of the shaft (23) with the “V” notch positioned over the shaft key.

With the impeller rotation still blocked, see Figure 5 and use a long piece of heavy bar stock to pry against the arm of the lathe dog in a counterclockwise direction (when facing the drive end of the shaft). **Use caution** not to damage the shaft or keyway. When the impeller breaks loose, remove the lathe dog, key and wood block.

**NOTE**

Do not remove the impeller until the rotating assembly has been removed from the pump casing.



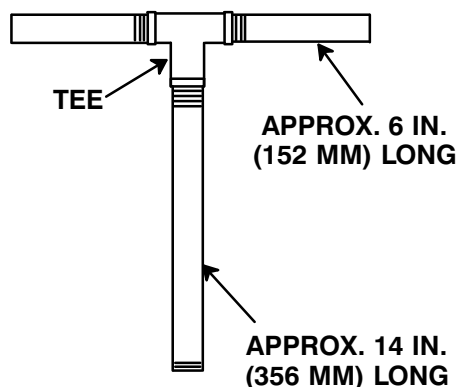
**Figure 5. Loosening Impeller (Figure 2)**

Disengage the hardware (12 and 32) securing the rotating assembly to the pump casing and remove

the spacers (33). Separate the rotating assembly by pulling straight away from the pump casing.

### NOTE

*An optional disassembly tool is available from the factory. If the tool is used, follow the instructions packed with it. A similar tool may be assembled using 1/2-inch pipe (schedule 80 steel or malleable iron) and a standard tee (see Figure 6). All threads are 1/2-inch NPT. **Do not pre-assemble the tool.***



**Figure 6. Rotating Assembly Tool**

*To install the tool, remove the vented plug (10, Figure 4) from the bearing housing, and screw the longest length of pipe into the vent hole until fully engaged. Install the tee, and screw the handles into the tee. Use caution when lifting the rotating assembly to avoid injury to personnel or damage to the assembly*

Remove the O-rings (8 and 9).

### Impeller Removal

#### (Figure 4)

With the rotating assembly removed from the pump casing, unscrew the impeller from the shaft. Use caution when unscrewing the impeller; tension on the shaft seal spring will be released as the impeller is removed. Inspect the impeller and replace if cracked or badly worn.

Remove the impeller adjusting shims (2); tie and tag the shims, or measure and record their thickness for ease of reassembly.

### Seal Removal

#### (Figure 4)

Slide the shaft sleeve and rotating portion of the seal off the shaft as a unit.

Use a pair of stiff wires with hooked ends to remove the stationary element and seat.

An alternate method of removing the stationary seal components is to remove the hardware (8 and 9) and separate the seal plate (4) and gasket (5) from the bearing housing (7). Position the seal plate on a flat surface with the impeller side down. Use a wooden dowel or other suitable tool to press on the back side of the stationary seat until the seat, O-rings, and stationary element can be removed.

Remove the shaft sleeve O-ring (24).

If no further disassembly is required, refer to **Seal Installation**.

### Shaft and Bearing Removal and Disassembly

#### (Figure 4)

When the pump is properly operated and maintained, the bearing housing should not require disassembly. Disassemble the shaft and bearings **only** when there is evidence of wear or damage.



Shaft and bearing disassembly in the field is not recommended. These operations should be performed only in a properly equipped shop by qualified personnel.

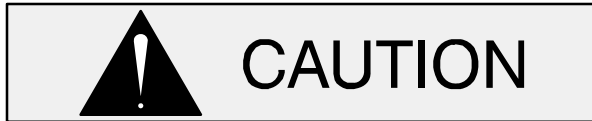
Remove the bearing housing drain plug and drain the lubricant. Clean and reinstall the drain plug.

Disengage the hardware (16 and 17) and slide the bearing cap (18) and oil seal (6) off the shaft. Remove the bearing cap gasket (19), and press the oil seal from the bearing cap.

Place a block of wood against the impeller end of the shaft (23) and tap the shaft and assembled bearings (21 and 25) from the bearing housing.

Pry or press the oil seals (6) from the bearing housing.

After removing the shaft and bearings, clean and inspect the bearings **in place** as follows.



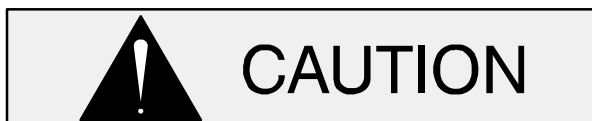
To prevent damage during removal from the shaft, it is recommended that bearings be cleaned and inspected **in place**. It is **strongly** recommended that the bearings be replaced **any** time the shaft and bearings are removed.

Clean the bearing housing, shaft and all component parts (except the bearings) with a soft cloth soaked in cleaning solvent. Inspect the parts for wear or damage and replace as necessary.



**Most cleaning solvents are toxic and flammable. Use them only in a well ventilated area free from excessive heat, sparks, and flame. Read and follow all precautions printed on solvent containers.**

Clean the bearings thoroughly in **fresh** cleaning solvent. Dry the bearings with filtered compressed air and coat with light oil.



Bearings must be kept free of all dirt and foreign material. Failure to do so will greatly shorten bearing life. **Do not** spin dry bearings. This may scratch the balls or races and cause premature bearing failure.

Rotate the bearings by hand to check for roughness or binding and inspect the bearing balls. If rotation is rough or the bearing balls are discolored, replace the bearings.

The bearing tolerances provide a tight press fit onto the shaft and a snug slip fit into the bearing housing. Replace the bearings, shaft, or bearing housing if the proper bearing fit is not achieved.

If bearing replacement is required, remove the out-board bearing retaining ring (20). Use a bearing puller to remove the bearings from the shaft.

**Pump Casing and Transition Chamber Removal (Ultra Mate Second Stage Model Only)**

(Figure 3)

The removal method for the Ultra Mate pump casing (1) depends on the configuration of the casing discharge port. If the discharge port is in a vertical position, install two eye hooks in opposing holes in the discharge flange. Use a suitable sling and hoist to remove the casing.

If the discharge port is in a horizontal position, fabricate a lifting device as shown in Figure 7 and screw it into the hole for the pipe plug (4). **Make certain** that the threaded end of the tool fully engages the threads in the casing. Use a suitable sling and hoist to remove the casing.

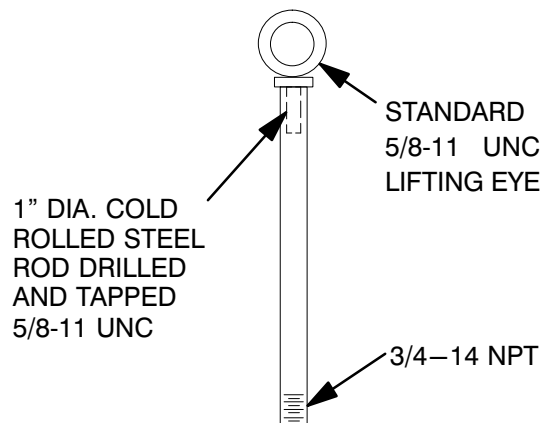


Figure 7. Casing Removal Tool



**Do not attempt to lift the complete pump unit using the lifting device. It is designed to facilitate removal or installation of individual components only. Additional weight may result in damage to the pump or failure of the lifting device.**

Remove the hardware (7 and 20) securing the pump casing to the transition chamber. Separate the pump casing and O-ring (21) from the transition chamber.

If the transition chamber requires removal from the Ultra V first stage pump, support the chamber using a suitable hoist and sling. See Figure 1 and remove the mounting hardware (8 and 9). Use the hoist and sling to remove the transition chamber and remove the gasket (7).

### Pump Casing and Transition Chamber Installation (Ultra Mate Second Stage Model Only)

#### (Figure 1)

Apply 'Permatex Aviation No. 3 Form-A-Gasket' to the mating surfaces and install a new gasket (7). Using the hoist and sling, position the transition chamber on top of the first stage pump casing. Secure the transition chamber with the hardware (8 and 9). Remove the sling from the transition chamber.

#### (Figure 3)

Lubricate a new O-ring (21) with a generous amount of grease and install it over the shoulder on the transition chamber (5). Using the same lifting method as used for disassembly, position the pump casing (1) over the transition chamber shoulder and secure it with the previously removed hardware (7 and 20). Remove the sling and, if used, the lifting device from the pump casing and reinstall the pipe plug (4).



**Do not attempt to lift the complete pump unit using the lifting device. It is designed to facilitate removal or installation of individual components only. Additional weight may result in damage to the pump or failure of the lifting device.**

### Shaft and Bearing Reassembly and Installation

#### (Figure 4)

Clean the bearing housing, shaft and all component parts (except the bearings) with a soft cloth soaked in cleaning solvent. Inspect the parts for wear or damage as necessary.



**Most cleaning solvents are toxic and flammable. Use them only in a well ventilated area free from excessive heat, sparks, and flame. Read and follow all precautions printed on solvent containers.**

Inspect the shaft for distortion, nicks or scratches, or for thread damage on the impeller end. Dress small nicks and burrs with a fine file or emery cloth. Replace the shaft if defective.

Position the inboard oil seal (6) in the bearing housing bore with the lip positioned as shown in Figure 4, Detail C. Press the oil seal into the housing until the face is **just flush** with the counterbored surface toward the inside of the housing.



To prevent damage during removal from the shaft, it is recommended that bearings be cleaned and inspected **in place**. It is **strongly** recommended that the bearings be replaced **any** time the shaft and bearings are removed.

#### NOTE

*Position the outboard bearing (21) on the shaft with the integral retaining ring on the bearing O.D. toward the drive end of the shaft.*

The bearings may be heated to ease installation. An induction heater, hot oil bath, electric oven, or hot plate may be used to heat the bearings. Bearings should **never** be heated with a direct flame or directly on a hot plate.

#### NOTE

*If a hot oil bath is used to heat the bearings, both the oil and the container must be **absolutely** clean. If the oil has been previously used, it must be **thoroughly** filtered.*

Heat the bearings to a uniform temperature **no higher than 250°F (120°C)**, and slide the bearings

onto the shaft, one at a time, until they are fully seated. This should be done quickly, in one continuous motion, to prevent the bearings from cooling and sticking on the shaft.

After the bearings have been installed and allowed to cool, check to ensure that they have not moved away from the shaft shoulders in shrinking. If movement has occurred, use a suitably sized sleeve and a press to reposition the bearings against the shaft shoulders.

If heating the bearings is not practical, use a suitably sized sleeve, and an arbor (or hydraulic) press to install the bearings on the shaft.



When installing the bearings onto the shaft, **never** press or hit against the outer race, balls, or ball cage. Press **only** on the inner race.

Secure the outboard bearing (21) to the shaft with the snap ring (20).

It is recommended that a sleeve be positioned against the inboard oil seal (6) to prevent the lip of the oil seal from rolling as the shaft and bearing are installed in the bearing housing. The O.D. of the sleeve should be just smaller than the bearing housing bore, while the I.D. of the sleeve should be just larger than the O.D. of the lip seal area of the shaft.

With the lip seal sleeve in place, lubricate the lip seal area of the shaft, and slide the shaft and assembled bearings into the bearing housing until the retaining ring on the outboard bearing seats against the bearing housing. Remove the lip seal sleeve.



When installing the shaft and bearings into the bearing bore, push against the outer race. **Never** hit the balls or ball cage.

Position the outboard oil seal (6) in the bearing housing bore with the lip positioned as shown in

Figure 4, Detail C. Press the oil seal into the housing until the face is **just flush** with the machined surface on the housing.

Press the oil seal (6) into the bearing cap (18) with the lip positioned as shown in Figure 2, Detail D. Replace the bearing cap gasket (19) and secure the bearing cap with the hardware (16 and 17). **Be careful** not to damage the oil seal lip on the shaft keyway.

Lubricate the bearing housing as indicated in **LUBRICATION**.

### Seal Installation

(Figures 4 and 8)



**Most cleaning solvents are toxic and flammable. Use them only in a well ventilated area free from excessive heat, sparks, and flame. Read and follow all precautions printed on solvent containers.**

Clean the seal cavity and shaft with a cloth soaked in fresh cleaning solvent. Inspect the stationary seat bore in the seal plate for dirt, nicks and burrs, and remove any that exist. The stationary seat bore **must** be completely clean before installing the seal.



A new seal assembly should be installed **any time** the old seal is removed from the pump. Wear patterns on the finished faces cannot be realigned during reassembly. Reusing an old seal could result in premature failure.

The seal is not normally reused because wear patterns on the finished faces cannot be realigned during reassembly. This could result in premature failure. If necessary to reuse an old seal in an emergency, **carefully** wash all metallic parts in fresh cleaning solvent and allow to dry thoroughly.

Inspect the seal components for wear, scoring, grooves, and other damage that might cause leak-

age. If any components are worn, replace the complete seal; **never mix old and new seal parts.**

If a replacement seal is being used, remove it from the container and inspect the precision finished faces to ensure that they are free of any foreign

matter.

To ease installation of the seal, lubricate the shaft sleeve, shaft sleeve O-ring and the external stationary seat O-ring with a very **small** amount of light lubricating oil. See Figure 8 for seal part identification.

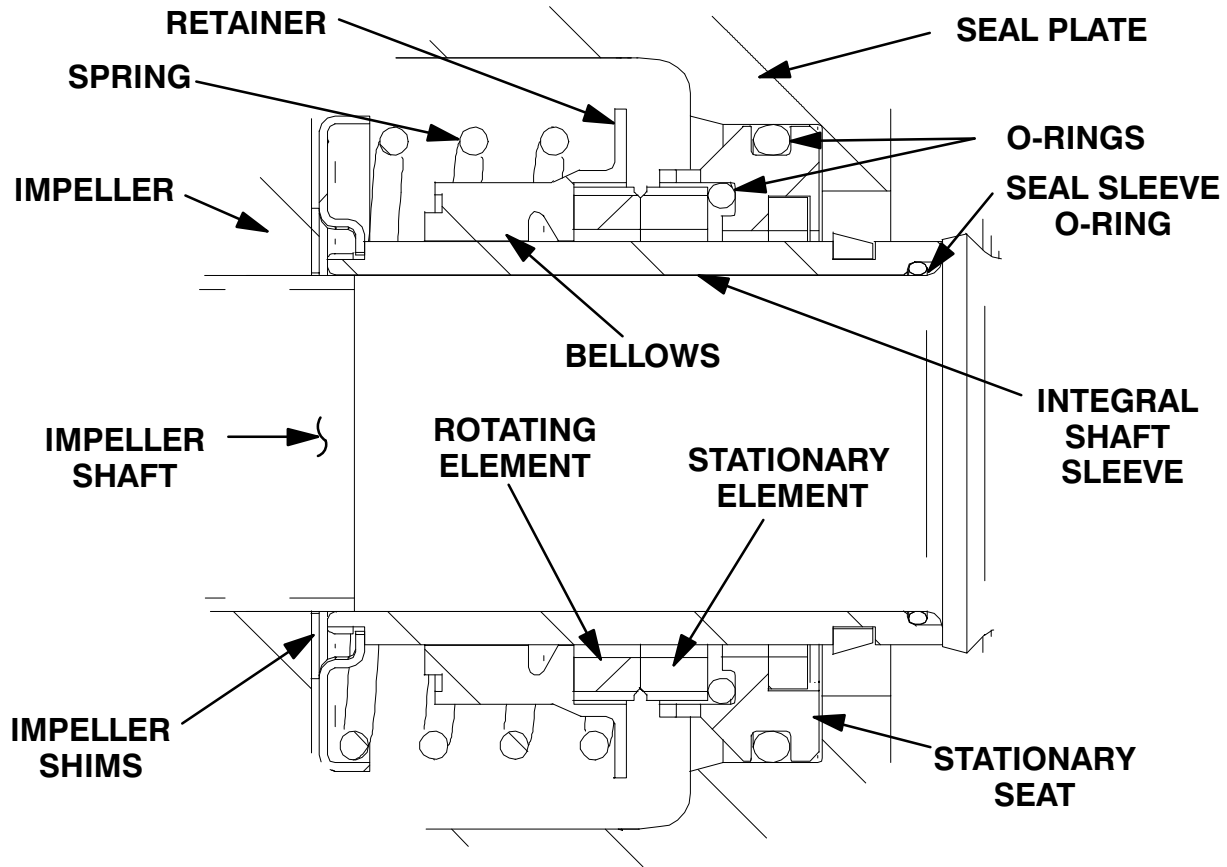


Figure 8. Cartridge Seal Assembly



This seal is not designed for operation at temperatures above 160°F (71°C). Do not use at higher operating temperatures.

If the seal plate was removed, install the seal plate gasket (5). Position the seal plate over the shaft and secure it to the bearing housing with the hardware (7 and 8).

To prevent damaging the shaft sleeve O-ring (24) on the shaft threads, stretch the O-ring over a piece of plastic tubing that the I.D. is a little larger than the O.D. of the shaft. Slide the tube over the shaft

threads, then slide the O-ring off the tube and onto the shaft. Remove the tube, and continue to slide the O-ring down the shaft until it seats against the shaft shoulder.

**When installing a new cartridge seal assembly,** remove the seal from the container, and remove the mylar storage tabs, if so equipped, from between the seal faces.

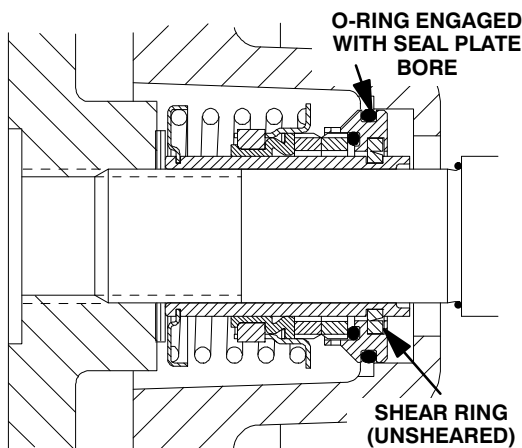


Some cartridge seal assemblies are equipped with mylar storage tabs between the seal faces. These storage tabs **must** be removed before installing the seal.



Lubricate the external stationary seat O-ring with light oil. Slide the seal assembly onto the shaft until the external stationary seat O-ring engages the bore in the seal plate.

Clean and inspect the impeller as described in **Impeller Installation and Adjustment**. Install the full set of impeller shims (2) provided with the seal, and screw the impeller onto the shaft until it is seated against the seal (see Figure 9).

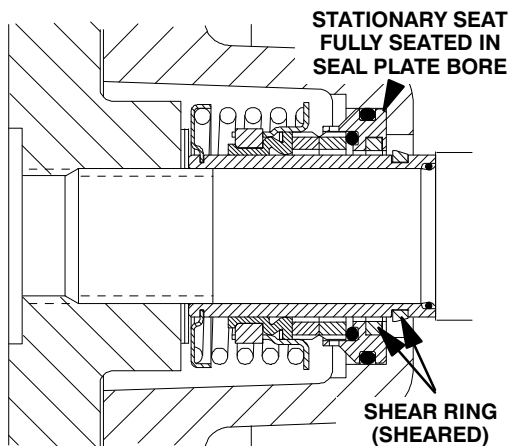


**Figure 9. Seal Partially Installed**

Continue to screw the impeller onto the shaft. This will press the stationary seat into the seal plate bore.

**NOTE**

*A firm resistance will be felt as the impeller presses the stationary seat into the seal plate bore.*



**Figure 10. Seal Fully Installed**

As the stationary seat becomes fully seated, the seal spring compresses, and the shaft sleeve will break the nylon shear ring. This allows the sleeve to slide down the shaft until seated against the shaft shoulder. Continue to screw the impeller onto the shaft until the impeller, shims, and sleeve are fully seated against the shaft shoulder (see Figure 10).

Measure the impeller-to-seal plate clearance, and remove impeller adjusting shims to obtain the proper clearance as described in **Impeller Installation and Adjustment**.

**If necessary to reuse an old seal** in an emergency, carefully separate the rotating and stationary seal faces from the bellows retainer and stationary seat.



A new seal assembly should be installed **any time** the old seal is removed from the pump. Wear patterns on the finished faces cannot be realigned during reassembly. Reusing an old seal could result in premature failure.

Handle the seal parts with extreme care to prevent damage. Be careful not to contaminate precision finished faces; even fingerprints on the faces can shorten seal life. If necessary, clean the faces with a non-oil based solvent and a clean, lint-free tissue. Wipe **lightly** in a concentric pattern to avoid scratching the faces.

**Carefully** wash all metallic parts in fresh cleaning solvent and allow to dry thoroughly.



**Do not** attempt to separate the rotating portion of the seal from the shaft sleeve when reusing an old seal. The rubber bellows will adhere to the sleeve during use, and attempting to separate them could damage the bellows.

Inspect the seal components for wear, scoring, grooves, and other damage that might cause leakage. Inspect the integral shaft sleeve for nicks or

cuts on either end. If any components are worn, or the sleeve is damaged, replace the complete seal; **never mix old and new seal parts.**

Install the stationary seal element in the stationary seat. Press this stationary subassembly into the seal plate bore until it seats squarely against the bore shoulder. A push tube made from a piece of plastic pipe would aid this installation. The I.D. of the pipe should be slightly larger than the O.D. of the shaft sleeve.

Slide the rotating portion of the seal (consisting of the integral shaft sleeve, spring centering washer, spring, bellows and retainer, and rotating element) onto the shaft until the seal faces contact.

Proceed with **Impeller Installation and Adjustment.**

### Impeller Installation And Adjustment

(Figure 4)

Inspect the impeller, and replace it if cracked or badly worn. Inspect the impeller and shaft threads for dirt or damage, and clean or dress the threads as required.



The shaft and impeller threads **must** be completely clean before reinstalling the impeller. Even the slightest amount of dirt on the threads can cause the impeller to seize to the shaft, making future removal difficult or impossible without damage to the impeller or shaft.

Install the same thickness of impeller adjusting shims (2) as previously removed. Apply 'Never-Seez' or equivalent to the shaft threads and screw the impeller onto the shaft until tight.

#### NOTE

*At the slightest sign of binding, immediately back the impeller off, and check the threads for dirt. Do not try to force the impeller onto the shaft.*

A clearance of .025 to .040 inch (0,64 to 1,02 mm) between the impeller and the seal plate is recommended for maximum pump efficiency. Measure

this clearance, and add or remove impeller adjusting shims as required.

*Proceed with **Rotating Assembly Installation** before installing the impeller capscrew and washer (26 and 27). The rotating assembly must be installed in the pump casing in order to torque the impeller capscrew.*

After the rotating assembly is installed in the pump casing, coat the threads of the impeller capscrew (27) with 'Never-Seez' or equivalent compound, and install the impeller washer (26) and capscrew; torque the capscrew to 90 ft. lbs. (1080 in. lbs. or 12,4 m. kg.).

### Rotating Assembly Installation

(Figure 2)

Install the O-rings (8 and 9) and lubricate them with light grease. Ease the rotating assembly into the pump casing using the installation tool. **Be careful** not to damage the O-ring.

Install the rotating assembly adjusting spacers (33) and secure the rotating assembly to the pump casing with the hardware (12 and 32).

To set the impeller and wear plate clearance, refer to the **Back Cover Installation And Adjustment.**

### Back Cover Installation And Adjustment

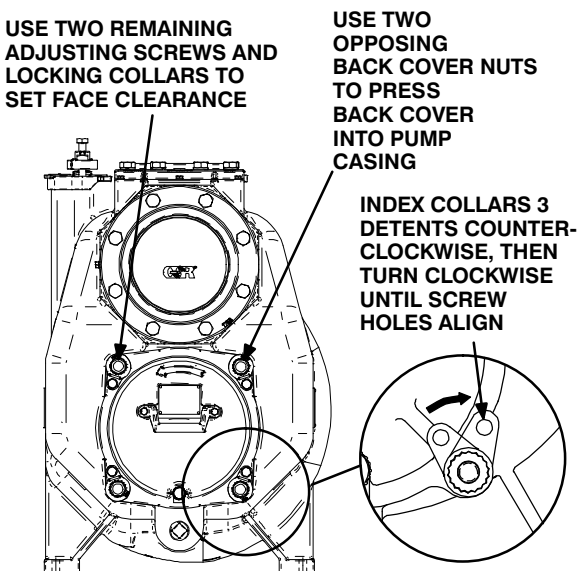
(Figures 2 and 11)

If the wear plate (5) was removed for replacement, carefully center it on the back cover and secure it with the hardware (7 and 8). The wear plate **must** be concentric to prevent binding when the back cover is installed.

Clearance between the impeller and wear plate is adjusted using four adjusting screws and locking collars. There are 18 detents on the I.D. of each locking collar (11). Indexing the collars one detent on the adjusting screws represents approximately .005 inch (0,13 mm) of wear plate clearance. The recommended clearance between the wear plate and the impeller is .010 to .020 inch (0,25 to 0,50 mm).

Replace the back cover O-rings (6 and 9) and lubricate them with a generous amount of No. 2 grease. Clean any scale or debris from the contacting sur-

faces in the pump casing that might interfere or prevent a good seal with the back cover.



**Figure 11. Installing and Adjusting Back Cover**

Screw the four adjusting screws (13) into the tapped holes in the back cover plate until they are **just flush** with the machined surface on the back side of the cover plate.

Align the back cover plate over the studs (3) and slide it into the pump casing. Use two back cover nuts (15) on diagonally opposing studs to press the back cover into the pump casing until the wear plate **just touches** the impeller when the shaft is turned by hand. **Tighten the back cover nuts evenly to avoid binding.**

With the wear plate just touching the impeller, turn the two free adjusting screws until they engage the pump casing. Position the locking collars over the adjusting screws so the holes in the collars for the locking screws align approximately with the holes in the cover plate.

Loosen the back cover nuts used to press the back cover into the pump casing one full turn.

Pull the collars off the adjusting screws, index them three detents counterclockwise, and reinstall the collars on the adjusting screws. Use the collars to turn the adjusting screws clockwise until the holes in the locking collars realign with the tapped screw holes in the back cover plate. Secure the locking collars to the back cover plate with the hardware

(12 and 14). Install the two remaining back cover nuts snugly against the adjusting screws.

Remove the first two back cover nuts from their studs. Turn the adjusting screws clockwise until they engage the pump casing. Install the locking collars and hardware (12 and 14). Reinstall the back cover nuts.

Be sure the wear plate does not scrape against the impeller.

Over time it may be necessary to repeat the adjustment process to compensate for normal wear between the impeller and wear plate. When all of the adjustment has been used on the back cover side of the pump, an additional 0.125 inch (3,2 mm) of adjustment may be obtained by removing the rotating assembly spacers (33).

Allow an installed pump to completely cool before draining liquid from the pump casing. Remove the back cover. Remove the rotating assembly adjusting shims, then reinstall the hardware securing the rotating assembly to the pump casing. Perform the back cover adjustment procedure described above to obtain the proper face clearance.

## PRESSURE RELIEF VALVE MAINTENANCE

### (Figure 2)

The back cover is equipped with a pressure relief valve to provide additional safety for the pump and operator (refer to **Liquid Temperature And Overheating** in **OPERATION**).

It is recommended that the pressure relief valve assembly be replaced at each overhaul, or any time the pump overheats and activates the valve. **Never** replace this valve with a substitute which has not been specified or provided by the Gorman-Rupp Company.

Periodically, the valve should be removed for inspection and cleaning. When reinstalling the relief valve, apply 'Loctite Pipe Sealant With Teflon No. 592' or equivalent compound on the relief valve threads. Position the valve as shown in Figure 2 with the discharge port pointing down.

### Final Pump Assembly

#### (Figure 2)

Install the shaft keys (22, Figure 4) in the keyways of both shafts and reconnect the power source. Be

sure to install any guards used over the rotating members.



**Do not operate the pump without the guards in place over the rotating parts. Exposed rotating parts can catch clothing, fingers, or tools, causing severe injury to personnel.**

Install the suction and discharge lines and open all valves. Make certain that all piping connections are tight, properly supported and secure.

**Be sure** the pump and power source have been properly lubricated, see **LUBRICATION**.

Remove the fill cover assembly (29) and fill the pump casing with clean liquid. Reinstall the fill cover, install the clamp bar (30) and secure it with the capscrew (31). Refer to **OPERATION**, Section C, before putting the pump back into service.

## LUBRICATION

### Seal Assembly

(Figure 4)

Before starting the pump, remove the vented plug (10) and fill the seal cavity with approximately 60 ounces (1,8 liters) SAE No. 30 non-detergent oil to the middle of the seal level sight gauge (14) and maintain it at the middle of the gauge. Clean and reinstall the vented plug. Maintain the oil at this level.

### NOTE

*The white reflector in the sight gauge must be positioned horizontally to provide proper drainage.*

## Bearings

(Figure 4)

The bearing housing was fully lubricated when shipped from the factory. Check the oil level regularly through the bearing cavity sight gauge (14) and maintain it at the middle of the gauge. When lubrication is required, add SAE No. 30 non-detergent oil through the hole for the air vent (12). **Do not** over-lubricate. Over-lubrication can cause the bearings to over-heat, resulting in premature bearing failure.

### NOTE

*The white reflector in the sight gauge must be positioned horizontally to provide proper drainage.*

Under normal conditions, drain the bearing housing once each year and refill with approximately 11 ounces (0,3 liter) clean oil. Change the oil more frequently if the pump is operated continuously or installed in an environment with rapid temperature change.



Monitor the condition of the bearing lubricant regularly for evidence of rust or moisture condensation. This is especially important in areas where variable hot and cold temperatures are common.

For cold weather operation, consult the factory or a lubricant supplier for the recommended grade of oil.

### Power Source

Consult the literature supplied with the power source, or contact your local power source representative.

**For U.S. and International Warranty Information,  
Please Visit [www.grpumps.com/warranty](http://www.grpumps.com/warranty)  
or call:  
U.S.: 419-755-1280  
International: +1-419-755-1352**

**For Canadian Warranty Information,  
Please Visit [www.grcanada.com/warranty](http://www.grcanada.com/warranty)  
or call:  
519-631-2870**