

Basic Pump



Self Priming Centrifugal Pump

Model RD2A31 – BAR

Size 3" x 2"

PUMP SPECIFICATIONS

Size: 3" x 2" (76 mm x 51 mm) Flanged.

Casing: Ductile Iron 65-45-12.

Maximum Operating Pressure 144 psi (993 kPa).*

Enclosed Type, Four Vane Impeller: Aluminum 356-T6.

Handles 1/4" (6,4 mm) Diameter Spherical Solids.

Impeller Shaft: Steel 1045.

Rotor: Copper Alloy C93200.

Bearing Housing: Ductile Iron 65-45-12.

Bearing Lubrication: Grease.

Body Cover: Ductile Iron 65-45-12.

Center/Spacer Plate: Ductile Iron 65-45-12.

Radial Bearing: Permanently Sealed Single Row Ball Type.

Thrust Bearing: Permanently Sealed Single Row Ball Type.

Gaskets: Buna-N, PTFE and Cork.

Priming: Rotary Vane Type Priming Pump.

Air Release Valve : Ductile Iron/Stainless Steel.

Optional Equipment: Cast Steel 70-36 Threaded Suction and Discharge Companion Flange Kit, Copper Alloy C93700 Impeller, Group Grind with Cast Iron Rotor; Stainless Steel 416 Impeller Shaft; Buna-N Seal, PTFE Seal with Fluorocarbon O-Ring, PTFE Seal with Buna-N O-Ring, Oil Filled Bearing Housing Assembly.

**Consult Factory for Applications Exceeding Maximum Pressure and/or Temperature Indicated.*

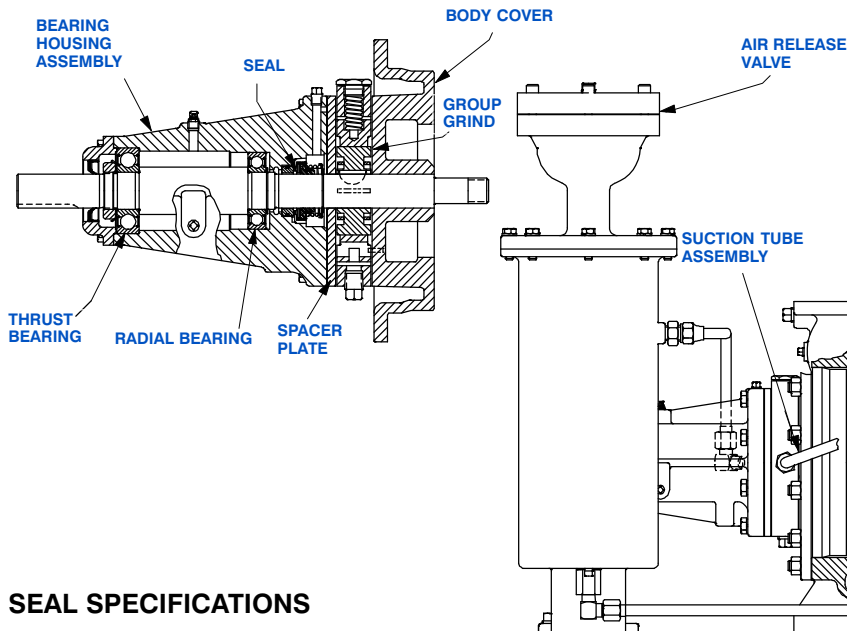
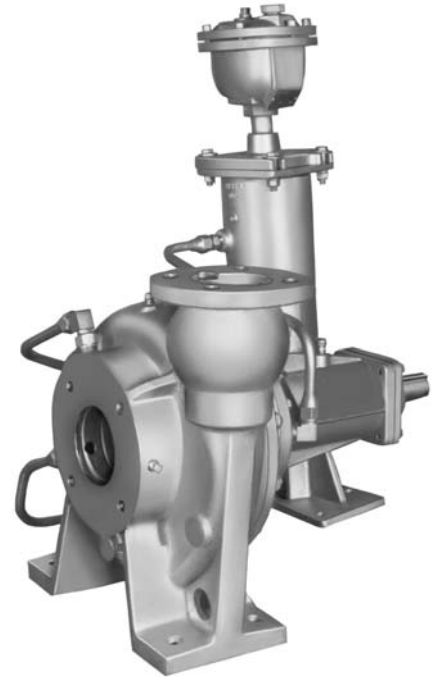

CAUTION
This Is Not A Water Pump. Use For Petroleum Products Only.

SEAL DETAIL

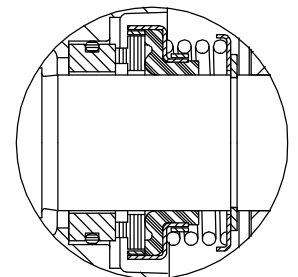

SEAL SPECIFICATIONS

Seal: Mechanical; Self-Lubricated. Fluorocarbon Elastomers (DuPont Viton® or Equivalent). Carbon Rotating Face; Ni-Resist Stationary Face; Maximum Temperature of Liquid Pumped is 160°F (71°C).*



GORMAN-RUPP PUMPS

www.grpumps.com

Specifications Subject to Change Without Notice

Printed in U.S.A.

Specification Data

SECTION 35, PAGE 210

OVERALL DIMENSIONS
and
APPROXIMATE WEIGHTS

PUMP NET WEIGHT: 215 LBS. (97,5 KG.)
SHIPPING WEIGHT: 225 LBS. (102,1 KG.)
EXPORT CRATE SIZE: 17.9 CU. FT. (0,51CU. M.)

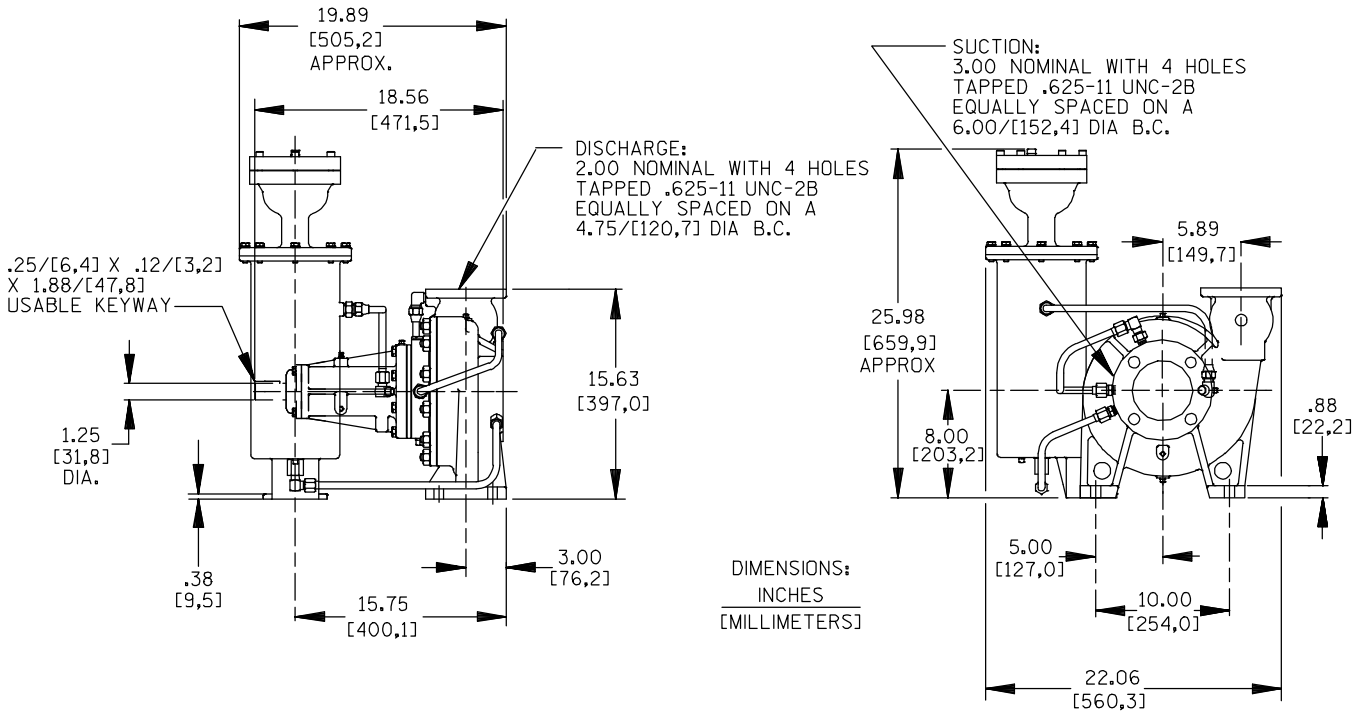

**PERFORMANCE
BASED ON
PETROLEUM
TRIMMED
IMPELLER**

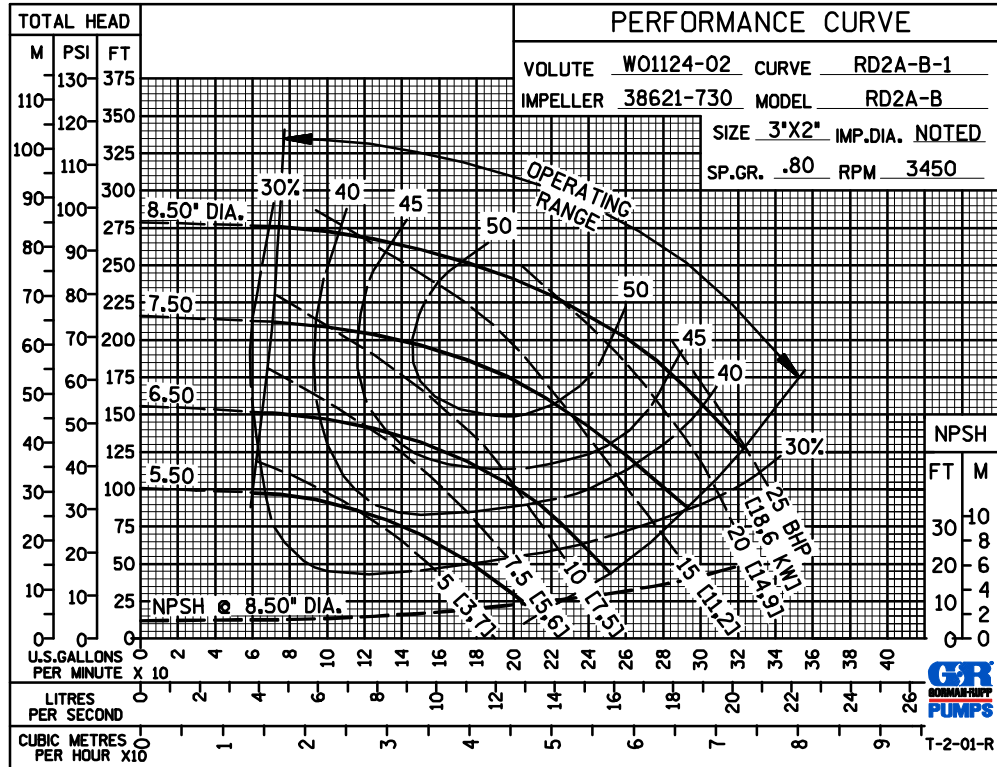

GORMAN-RUPP PUMPS

www.grpumps.com

Specifications Subject to Change Without Notice

Printed in U.S.A.

50 HERTZ
PERFORMANCE
BASED ON
PETROLEUM
TRIMMED
IMPELLER

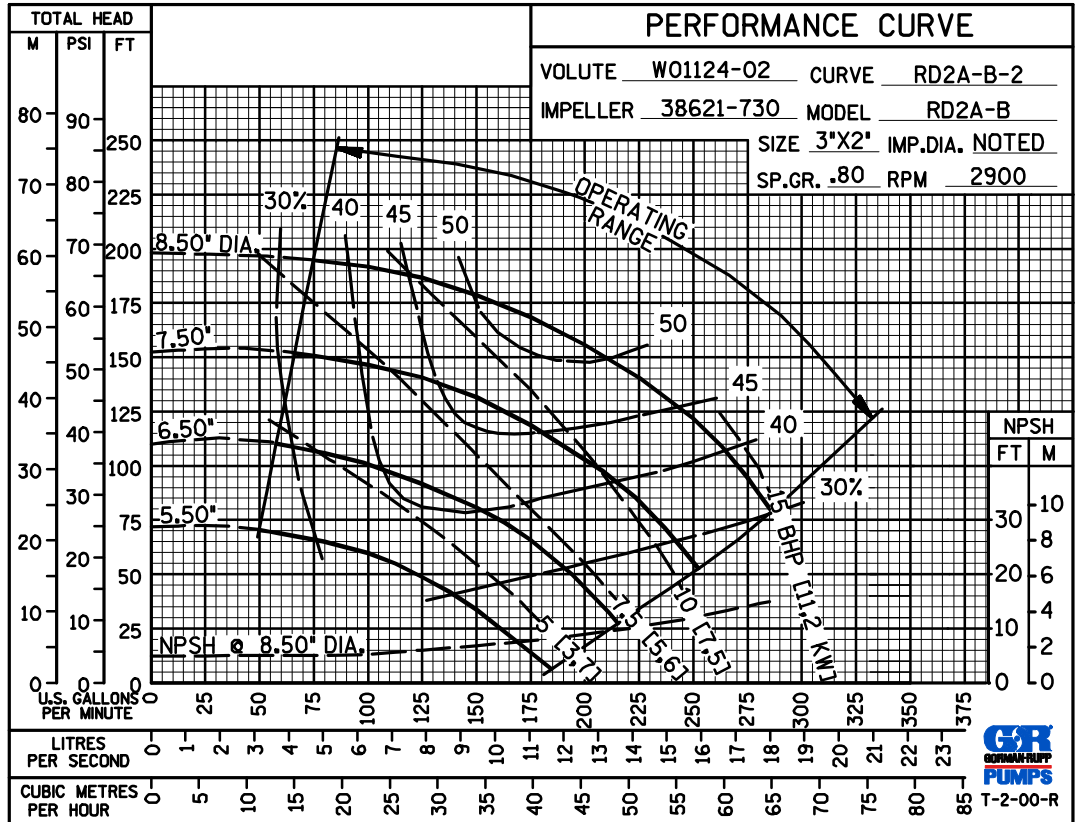

GORMAN-RUPP PUMPS

www.grpumps.com

Specifications Subject to Change Without Notice

Printed in U.S.A.